

Critical Area Determination

Staff Report and Decision

February 25, 2019

| | |
|-----------------------------|---|
| Project No: | CAO17-007 (SEP18-021) |
| Project Description: | Request for approval of a critical areas determination in order to modify a steep slope and to install a stormwater drainage system within and across a watercourse and watercourse buffer associated with construction of a new single family residence. |
| Location: | 4634 E Mercer Way/Mercer Island WA (Parcel Number 7558700008) |
| Applicant/Owner: | Paul Maksimchuk / Four Season Homes LLC |
| Staff Decision: | Approved with conditions |
| Staff Contact: | Robin Proebsting, Senior Planner |

A. Introduction.

1. **Site Description:** The subject site is approximately 21,350 square feet (sqft) and is located between E Mercer Way and the Lake Washington shoreline, taking access from E Mercer Way via a private access road. The site slopes from west to east and is currently treed and undeveloped. Mapped landslide and erosion hazard area encompass the site, with portions mapped as exceeding a 40% slope. The underlying short plat designates 5-ft utility easements along the north and south property lines of the subject site and adjacent upslope and downslope properties. Lake Washington is approximately 320 feet (ft) to the east of the subject site.

The subject site is zoned R-15 (Residential, 15,000 sqft minimum lot size) and is surrounded on all sides with lots zoned R-15 developed with single-family homes.

2. **Description of proposal:** The applicant proposes to alter the steep slopes on the subject site as part of proposed future house construction and install storm drainage infrastructure within southern 5-ft utility easement to convey stormwater from the subject site to Lake Washington. The 5-ft utility easement in which the stormwater infrastructure is proposed, intersects a Type 3 watercourse and associated 35-ft buffer.
3. **Project History:** A building permit (Permit #1507-166, issued September 13, 2016) was previously issued to this property; the building permit was appealed (APL16-002). A portion of

the appeal was denied November 8, 2016. The building permit was subsequently revoked by the City. The applicant submitted an application for a revised building permit application (Permit #1507-166) and Critical Area Determination (CAO17-007) on June 14, 2017. The applicant did not apply for SEPA review at the same time as the revised building permit and Critical Areas Determination. The applicant applied for SEPA review November 7, 2018. This Critical Areas Determination will be issued concurrently with a SEPA determination. The City anticipates issuing the building permit after the close of the appeal period for the Critical Areas Determination and SEPA determination.

4. **Site visit:** Senior Planner Robin Proebsting conducted a site visit on November 6, 2017 and took photos of the site (Exhibit 15).

B. Findings of Fact & Conclusions of Law.

1. **Date Determined to be Complete:** A letter of incompleteness was issued on July 11, 2017 (Exhibit 3). Additional information was submitted by the applicant in response to the letter on August 31, 2017 making the application complete.
2. **Notice of Application and Comment Period:** Notice of Application (Exhibit 16) was issued September 11, 2017, and the public comment period ran from September 11, 2017 to October 11, 2017.
3. **SEPA Notice and Comment Period:** The applicant did not apply for SEPA review at the same time as the Critical Area Determination. After reviewing plans for the Critical Area Determination (CAO17-007) and revised building permit (1507-166REV), staff suggested that SEPA was necessary in the first review letter, sent October 26, 2017. The applicant submitted an application for SEPA review on November 7, 2018, project SEP 18-021. The SEPA Notification / Notice of Application (Exhibit 4) was issued November 13, 2018 and the public comment period ran from November 13, 2018 to December 13, 2018.
4. **Public Comment:** Public comment: 16 public comment letters were received on project CAO17-007 and 11 public comment letters were received on project SEP18-021 (Exhibit 14 – combined public comment). Topics raised by public comment include:

- a. The potential for the private access road between E Mercer Way and the subject site to become damaged, made more unstable due to construction traffic, and/or generate erosion;

Staff review: The applicant has proposed to limit the load size of trucks accessing the subject site during construction, monitor the steep slopes adjacent to the private access road daily for signs of movement when truck traffic is expected, and implement a contingency plan if needed (Exhibit 7).

A condition of approval has been added to this decision, requiring specifics of a proposed contingency plan to be submitted, reviewed, and approved by City staff prior to building permit issuance.

- b. Potential impacts to homeowners' access to their properties due to construction traffic;

Staff review: An approved construction management plan will be required prior to issuance of a building permit pursuant to MICC 17.14, section 105.6. The construction management plan shall include measures to mitigate impacts resulting from use of the street for construction related haul routes, which includes the types of concerns raised by public comment.

- c. Increased load on the downslope retaining wall at 4640 E Mercer Way;

Staff review: The project geotechnical engineer has indicated that the proposed construction will not have adverse impacts on the existing wood wall and the adjacent property to the east based on the 30-ft distance between the proposed construction and the retaining wall on the neighboring property. Further, the project geotechnical engineer recommends “monitoring points be established on the existing wood wall and monitoring be conducted during earthwork”. A condition of approval has been added to this decision, requiring that the specifics of a proposed contingency plan be submitted, reviewed, and approved by the City prior to building permit issuance.

- d. Concern about off-site impacts due to finished project, including increased stormwater and muddy runoff to neighboring properties;

Staff review: The drainage design is proposed to capture stormwater from all hard surfaces of the new construction, including roofs, patios, walkways, and driveway. The proposed drainage system will collect stormwater from the proposed development via a tightline directly to Lake Washington (Exhibit 17). The drainage design is required to meet the applicable stormwater manual standards and will be reviewed for compliance at building permit review.

- e. Slope stability due to tree removal and resulting changed hydrology;

Staff review: The project geotechnical engineer has provided a statement of risk for the project, stating that development practices are proposed for the alteration that would render the development as safe as if it were not located in a geologic hazard area (Exhibit 6).

- f. The possible presence of a bald eagle nest;

Staff response: According to MICC 19.10.130, “persons must comply with all applicable federal and state laws, rules and regulations including without limitation the Endangered Species Act, the Bald Eagle Protection Act and the Migratory Bird Treaty Act, as now existing or hereinafter adopted or amended.” The applicant is obligated to comply with the laws stated in the code. There are no additional local requirements pertaining to bald eagles. A condition of approval has been added to this decision requiring field verification of the presence of bald eagles, and if a presence is found, documentation of compliance with all applicable federal and state laws.

- g. The potential for the drainage outfall on shoreline to convey silt to Lake Washington.

Staff review: The drainage design is proposed to capture stormwater from the new construction (Exhibit 5). Drainage design is required to meet stormwater manual standards, which will be reviewed as part of the associated building permit.

5. **SEPA compliance:** A SEPA Determination of Non-significance (Exhibit 13) is being issued concurrently with this decision.
6. **MICC 19.07.060(D)(1) - Development Conditions.** Alterations of geologic hazard areas may occur if the code official concludes that such alterations: a. Will not adversely impact other critical areas; b. Will not adversely impact (e.g., landslides, earth movement, increase surface water flows, etc.) the subject property or adjacent properties; c. Will mitigate impacts to the geologic hazard area consistent with best available science to the maximum extent reasonably possible such that the site is determined to be safe; and d. Include the landscaping of all disturbed areas outside of building footprints and installation of all impervious surfaces prior to final inspection.

Staff response: The applicant has provided geotechnical memos (Exhibits 6a through 6e) providing recommendations for design parameters for site improvements. The project submittal has been reviewed by the City's consulting geotechnical engineer who has made recommendations for issues to be further addressed at building permit (Exhibit 10).

7. **MICC 19.07.060(D)(2) – Steep slopes on subject site: Statement of Risk.** Alteration within geologic hazard areas may occur if the development conditions listed above are satisfied and the geotechnical professional provides a statement of risk with supporting documentation indicating that one of the following conditions can be met:
 - a. The geologic hazard area will be modified, or the development has been designed so that the risk to the lot and adjacent property is eliminated or mitigated such that the site is determined to be safe;
 - b. Construction practices are proposed for the alteration that would render the development as safe as if it were not located in a geologic hazard area;
 - c. The alteration is so minor as not to pose a threat to the public health, safety and welfare; or
 - d. An evaluation of site-specific subsurface conditions demonstrates that the proposed development is not located in a geologic hazard area

Staff response: The applicant provided a geotechnical memo (Exhibit 6d) which includes the statement “development practices are proposed for the alteration that would render the development as safe as if it were not located in a geologic hazard area”. The memo notes that the geotechnical engineering aspects of the architectural and civil plans were reviewed to confirm incorporation of the geotechnical recommendations made in previously submitted geotechnical reports. The project submittal has been reviewed by the City's consulting geotechnical engineer who has made recommendations for issues to be further addressed at building permit (Exhibit 10).

8. **MICC 19.07.070(A) Watercourses – Designation and Typing:** Watercourses shall be designated as Type 1, Type 2, Type 3 and Restored according to the following criteria: [...] (3) Type 3 Watercourse. Watercourses or reaches of watercourses with intermittent or seasonal flow and not used by fish.

Staff response: The applicant submitted a critical areas study stating that the subject site contains a Type 3 watercourse (Exhibit 11). The watercourse type was confirmed by the City's

peer reviewer (Exhibit 12). Type 3 watercourses are subject to a standard buffer of 35 feet (MICC 19.07.070(B)).

9. **MICC 19.07.030** – New Utility Facilities. New utilities are allowed in critical areas and buffers subject to the following:

a. Construction is consistent with best management practices;

Staff response: The applicant proposes to install temporary erosion and sediment control, consistent with best management practices.

b. The facility is designed and located to mitigate impacts to critical areas consistent with best available science;

Staff response: The facility was designed to avoid impacts by conveying water through a tightline, rather than discharging stormwater outside the watercourse and associated buffer, which could have reduced slope stability and exacerbated drainage issues on the downslope property. The impact of the proposed tightline has been minimized by placing the pipe above ground, instead of below ground, which would have required trenching. Lastly, use of a tightline will eliminate impacts over time by allowing flushing to be done without disturbing the watercourse buffer (Exhibit 11).

c. Impacts to critical areas are mitigated to the greatest extent reasonably feasible so there is no net loss in critical area functions;

Staff response: The proposed tightline will be installed above ground, with pipe anchors placed to avoid trees (Exhibit 5). Existing vegetation within the watercourse buffer consists of English ivy and maintained lawn (Exhibit 11) causing minimal impact to ecological functions and values. No mitigation is proposed. The applicant's critical area study was reviewed by the City's peer review, who confirmed that no mitigation is necessary for this scope of work (Exhibit 12).

d. Utilities shall be contained within the footprint of an existing street, driveway, paved area, or utility crossing where possible; and

Staff response: There is no existing street, driveway, paved area or utility crossing in the utility easement in which the tightline is proposed to be installed. This criterion does not apply.

e. The code official may require a critical area study or restoration plan for this allowed alteration.

Staff response: The applicant submitted a critical area study for this allowed alteration.

10. **MICC 19.07.110(F)(1)(d)** - No development shall be undertaken within the shorelands without first obtaining a shoreline exemption permit, substantial development permit, conditional use permit, and/or a variance permit in accordance with all applicable procedures unless it qualifies under a categorical exemption.

Staff response: A stormwater tightline is proposed to be installed within the shoreline jurisdiction. The applicant's critical area study (Exhibit 11) indicates that this development falls within the exemption WAC 173-27-040(2)(g). Staff agrees that this is the correct exemption for

this scope of work. A condition of approval has been added to this decision requiring application and issuance of a Shoreline Exemption Permit prior to building permit issuance.

9. Pursuant to MICC 19.17, 19.18, and 19.19, the City shall collect impact fees at the time of building permit issuance, in the amount of the impact fee at the time of payment. This requirement has been noted below in section D noting the requirement to pay impact fees.
10. **MICC 19.15.150** - Construction or substantial progress toward construction of a development proposal for which a land use review approval has been granted must be undertaken within two years of the date of notice of decision of the land use review.

Staff response: This requirement has been noted below in section D, setting an expiration date consistent with this code standard.

C. Conditions of Approval. Approval of this critical areas determination is conditioned upon compliance with the following conditions of approval, which are intended to ensure compliance with the applicable standards of Title 19 of the Mercer Island City Code.

1. Future construction permits associated with this approval shall be in substantial conformance with the development plan set (Exhibit X).
2. Prior to building permit issuance, the applicant shall provide a contingency plan in the event that the proposed monitoring along the private access road between E Mercer Way and the subject site indicates movement of the steep slope.
3. Prior to building permit issuance, the applicant shall provide a contingency plan in the event that the proposed monitoring along the wood retaining wall at 4640 E Mercer Way indicates signs of damage.
4. Prior to building permit issuance, the applicant shall determine the applicability of applicable federal and state laws, rules and regulations pertaining to bald eagle protection, including without limitation the Endangered Species Act, the Bald Eagle Protection Act and the Migratory Bird Treaty Act, and if found to be applicable, provide documentation that these rules and regulations have been followed.
5. Prior to building permit issuance, the applicant shall satisfactorily resolve the items listed in the December 21, 2018 review memo for this project prepared by Michele Lorilla, P.E (Exhibit 10), which is incorporated herein by reference.

D. Development Regulation Compliance – Disclosure. The following are intended to disclose specific requirements of the Mercer Island City Code that will need to be addressed by the applicant. The following are not intended to comprehensively summarize all code requirements; the applicant shall have the burden of demonstrating that the proposed development complies with applicable standards.

1. Compliance with all local, state, and federal regulations is required.
2. Construction or substantial progress toward construction shall be undertaken within two years of the date of this decision.
3. Prior to building permit issuance, school impact fees shall be paid, unless deferral of payment is sought pursuant to MICC 19.17.080.

4. Prior to building permit issuance, park impact fees shall be paid, unless deferral of payment is sought pursuant to MICC 19.18.060.
5. Prior to building permit issuance, transportation impact fees shall be paid, unless deferral of payment is sought pursuant to 19.19.060.
6. The applicant is responsible for obtaining all applicable approvals from other agencies, including but not limited to a Hydraulic Project Approval from the Washington Dept. of Fish and Wildlife.

E. Decision / Recommendation

Based upon the above noted Findings of Fact and Conclusions of Law, critical areas determination application CAO17-007, as depicted in Exhibit 5, is hereby conditionally **APPROVED**. This decision is final, unless appealed in writing consistent with adopted appeal procedures, MICC 19.15.130, and all other applicable appeal regulations.

Approved this 25th day of February, 2019

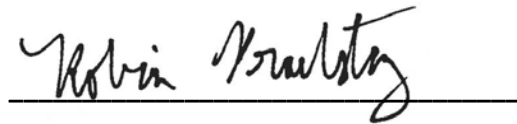

Robin Proebsting
Senior Planner
Community Planning and Development
City of Mercer Island

If you desire to file an appeal, you must submit the appropriate form, available from the Community Planning and Development, and file it with the City Clerk within fourteen (14) days from the date this decision is signed. Upon receipt of a timely complete appeal application and appeal fee, an appeal hearing will be scheduled.

Please note that the City will provide notice of this decision to the King County Department of Assessment, as required by State Law (RCW 36.70B.130). Pursuant to RCW 84.41.030(1), affected property owners may request a change in valuation for property tax purposes notwithstanding any program of revaluation by contacting the King County Department of Assessment at (206) 296-7300.

Exhibit List

1. Development Application Coversheet, dated June 14, 2017
2. Notice of Decision for Building Code Appeal (APL16-002) dated November 8, 2016
3. Letter of Incompletion prepared by Evan Maxim, City of Mercer Island, dated July 12, 2017
4. The SEPA Notification / Notice of Application
5. Plan set dated May 8, 2018
6. Geotechnical memos
 - a. Memo prepared by PanGEO dated February 4, 2016
 - b. Memo prepared by PanGEO dated July 11, 2014
 - c. Memo prepared by PanGEO dated June 1, 2016
 - d. Memo prepared by PanGEO dated July 19, 2016

- e. Memo prepared by PanGEO dated August 12, 2016
- 7. Memo prepared by PanGEO dated May 2, 2018.
- 8. Email from Marc McGinnis, P.E., Geotech Consultants, Inc. dated September 4, 2018
- 9. Email from Don Cole, City of Mercer Island Building Official, dated February 15, 2019
- 10. Memo prepared by Michele Lorilla, P.E., dated December 21, 2018
- 11. Critical Area Study prepared by Wetland Resources, Inc. dated October 1, 2018.
- 12. Memo prepared by ESA, dated February 21, 2019
- 13. SEPA threshold determination, dated February 25, 2019
- 14. Public Comment
- 15. Site visit photos taken by Robin Proebsting, City of Mercer Island, November 6, 2017
- 16. Public Notice of Application for CAO17-007 dated September 11, 2017
- 17. Memo from Litchfield Engineering, dated January 22, 2019

CITY OF MERCER ISLAND
DEVELOPMENT SERVICES GROUP

9611 SE 36TH STREET | MERCER ISLAND, WA 98040
 PHONE: 206.275.7605 | www.mercergov.org



| CITY USE ONLY | | |
|------------------------|-----------|---------|
| PERMIT # | RECEIPT # | FEE |
| CA017-2017 | 158479 | 2881.47 |
| Date Received: 6/14/17 | | |

Received By:

DEVELOPMENT APPLICATION

| | | |
|--|---|--|
| STREET ADDRESS/LOCATION 4634 E. Mercer Way, Mercer Island, WA | | ZONE R-15 |
| COUNTY ASSESSOR PARCEL #'S 755870008 | | PARCEL SIZE (SQ. FT.) Approximately 21,350 SF |
| PROPERTY OWNER (required) Four Season Homes LLC | ADDRESS (required) 32814 38TH AVE S., Federal Way, 98001 | CELL/OFFICE (required) (253) 334-9209 E-MAIL (required) paulnikolaevich@yahoo.com |
| PROJECT CONTACT NAME Paul Maksimchuk | ADDRESS 32814 38th AVE S., Federal Way, 98001 | CELL/OFFICE (253) 334-9209 E-MAIL paulnikolaevich@yahoo.com |
| TENANT NAME N/A | ADDRESS N/A | CELL PHONE N/A E-MAIL N/A |

DECLARATION: I HEREBY STATE THAT I AM THE OWNER OF THE SUBJECT PROPERTY OR I HAVE BEEN AUTHORIZED BY THE OWNER(S) OF THE SUBJECT PROPERTY TO REPRESENT THIS APPLICATION, AND THAT THE INFORMATION FURNISHED BY ME IS TRUE AND CORRECT TO THE BEST OF MY KNOWLEDGE.

SIGNATURE

DATE 6-14-17

PROPOSED APPLICATION(S) AND CLEAR DESCRIPTION OF PROPOSAL (PLEASE USE ADDITIONAL PAPER IF NEEDED):
 Applicant requests Critical Areas Determination for alteration of steep slope and steep slope buffer.

ATTACH RESPONSE TO DECISION CRITERIA IF APPLICABLE

CHECK TYPE OF LAND USE APPROVAL REQUESTED:

| APPEALS | DEVIATIONS Continued | SUBDIVISION SHORT PLAT Continued |
|--|---|--|
| <input type="checkbox"/> Building (+cost of file preparation) | <input type="checkbox"/> Impervious Surface (5% Lot overage) | <input type="checkbox"/> Short Plat Amendment |
| <input type="checkbox"/> Land use (+cost of verbatim transcript) | <input type="checkbox"/> Shoreline | <input type="checkbox"/> Final Short Plat Approval |
| <input type="checkbox"/> Code Interpretation | <input type="checkbox"/> Wet Season Construction Moratorium | VARIANCES (Plus Hearing Examiner Fee) |
| CRITICAL AREAS | ENVIRONMENTAL REVIEW (SEPA) | <input type="checkbox"/> Type 1** |
| <input checked="" type="checkbox"/> Determination | <input type="checkbox"/> Checklist: Single Family Residential Use | <input type="checkbox"/> Type 2*** |
| <input type="checkbox"/> Reasonable Use Exception | <input type="checkbox"/> Checklist: Non-Single Family Residential Use | OTHER LAND USE |
| DESIGN REVIEW | <input type="checkbox"/> Environmental Impact Statement | <input type="checkbox"/> Accessory Dwelling Unit |
| <input type="checkbox"/> Administrative Review | SHORELINE MANAGEMENT | <input type="checkbox"/> Code Interpretation Request |
| <input type="checkbox"/> Design Review – Major | <input type="checkbox"/> Exemption | <input type="checkbox"/> Comprehensive Plan Amendment (CPA) |
| <input type="checkbox"/> Design Review – Minor | <input type="checkbox"/> Semi-Private Recreation Tract (modification) | <input type="checkbox"/> Conditional Use (CUP) |
| WIRELESS COMMUNICATIONS FACILITIES | <input type="checkbox"/> Semi-Private Recreation Tract (new) | <input type="checkbox"/> Lot Line Revision |
| <input type="checkbox"/> Wireless Communications Facilities-6409 Exemption | <input type="checkbox"/> Substantial Dev. Permit | <input type="checkbox"/> Lot Consolidation |
| <input type="checkbox"/> New Wireless Communications Facility | SUBDIVISION LONG PLAT | <input type="checkbox"/> Noise Exception |
| DEVIATIONS | <input type="checkbox"/> Long Plat | <input type="checkbox"/> Reclassification of Property (Rezoning) |
| <input type="checkbox"/> Changes to Antenna requirements | <input type="checkbox"/> Subdivision Alteration to Existing Plat | <input type="checkbox"/> ROW Encroachment Agreement (requires separate ROW Use Permit) |
| <input type="checkbox"/> Changes to Open Space | <input type="checkbox"/> Final Subdivision Review | <input type="checkbox"/> Zoning Code Text Amendment |
| <input type="checkbox"/> Fence Height | SUBDIVISION SHORT PLAT | |
| <input type="checkbox"/> Critical Areas Setback | <input type="checkbox"/> Short Plat | |
| | <input type="checkbox"/> Deviation of Acreage Limitation | |

**Includes all variances of any type or purpose in all zones other than single family residential zone: B,C-O,PBZ,MF-2,MF2L,MF-2L, MF-3,TC,P)
 ***Includes all variances of any type or purpose in single family residential zone: R-8.4, R-9.6, R-12, R-15)



CITY OF MERCER ISLAND

9611 SE 36th Street • Mercer Island, WA 98040-3732
(206) 275-7605 • www.mercergov.org

NOTICE OF DECISION FOR BUILDING CODE APPEAL (APL16-002)

These matters came before the Mercer Island Building Code Board of Appeals on October 25, 2016 for a public hearing on a building permit appeal. Rita Latsinova of Stoel Rives represented Coey DuBrowa, the appellant. Don Cole, Building Official presented on behalf of the City and Andrew Murphy of Hillis Clark Martin and Peterson spoke on behalf of the applicant, Barcelo Homes. After review of the staff report with exhibits and considering the oral testimony presented during the course of the public hearing, the Building Code Board of Appeals makes the following Findings of Facts and Conclusions of Law in these matters.

I. PROCEDURE SUMMARY

1. On August 29, 2016, a building permit was approved (1507-166) for the vacant lot to be developed at 4634 East Mercer Island, Washington ("Barcelo Property").
2. On September 2, 2016, the appellant, Corey DuBrowa, filed an appeal of the building permit (APL16-002).
3. On September 30, 2016, the date, time and place for the public hearing was set for October 25, 2016.
4. A notice of public hearing was sent on September 30, 2016.
5. On October 25, 2016, the Building Code Board of Appeals, after reviewing the staff report and hearing testimony from the appellant, the City and the applicant, denied the appeal.

II. RECORD

1. The Building Code Board of Appeals considered the following in making its decision:
 - a. Staff Report, prepared by Don Cole, Building Official, dated October 24, 2016, with the following exhibits:
 - i. Building Permit Approval, dated August 29, 2016
 - ii. Appeal Form (statement), date stamped September 2, 2016
 - iii. Notice of Public Hearing, sent September 30, 2016
 - b. Exhibits 1-24 submitted by appellant at the hearing.
2. The Building Code Board of Appeals considered the testimony of:
 - a. Rita Latsinova of Stoel Rives, representing the appellant.
 - b. Bob Rohrbach, retired building official, formerly employed as Building Official for the City of Mercer Island.
 - c. Edward Heavey, P.E. of Landau Associates, a geotechnical engineer.
 - d. Don Cole, Building Official for the City of Mercer Island.
 - e. Andrew Murphy of Hillis Clark Martin and Peterson, representing the applicant.

II. FINDINGS OF FACT

Mercer Island City Code ("MICC") 17.14.010, Section 113.1 provides procedures to appeal decisions of the Building Official relative to Title 17, Construction Codes, as established by chapter 3.28 MICC, Building. The following provides an analysis of the facts regarding this appeal:

1. The Appellant, Corey DuBrowa, owns the property at 4614 East Mercer Way, Mercer Island, Washington ("DuBrowa Property").
2. The Permit Applicant, Barcelo Homes, owns the vacant lot to be developed at 4634 East Mercer Way, Mercer Island, Washington ("Barcelo Property").
3. The DuBrowa Property shares a common private access roadway with the Barcelo Property.
4. Barcelo Homes submitted a permit application on July 22, 2015 to construct a single family home on the Barcelo Property.
5. Barcelo Homes transferred ownership of the 4634 East Mercer Way property to Four Seasons Builds, LLC, by statutory warranty deed on August 2, 2016, recorded on August 3, 2016.
6. MICC 17.14.010, Section 105.3.1, Action on Application, requires the Building Official to issue a permit if the Building Official, following review of the application, is satisfied that the proposed work conforms to the requirements of the construction codes and the Construction Administrative Code and laws and ordinances applicable thereto.
7. Consistent with approval criteria found in MICC 17.14.010, Section 105.3.1 and other relevant sections of Title 17 MICC, staff reviewed for conformance with adopted codes and approved the plans on August 29, 2016 (Exhibit 1). The permit was issued on September 13, 2016.
8. The Appellant, DuBrowa, submitted an appeal of several specific decisions to the Building Board of Appeals on September 2, 2016 (Exhibit 2).
9. Pursuant to MICC 3.28.020, "... the board shall hear all appeals..." without provisions for staff to reject an application that may be incorrectly filed.
10. Following receipt of the appeal, the City of Mercer Island convened the Building Board of Appeals and scheduled a public hearing for October 25, 2016. A Notice of Public Hearing was sent on September 30, 2016 (Exhibit 3).
11. Specific items within the DuBrowa appeal are as follows:
 - a) An Appeal regarding "... MICC Chapter 19.07 (Environment) and MICC Chapter 19.10 (Tree Code)..." which are regulated under the provisions of the Unified Land Development Code, Title 19 MICC.
 - b) An Appeal regarding "...critical and hazardous area protections..." which are regulated under the provisions of the Unified Land Development Code, Title 19 MICC.
 - c) An Appeal regarding "... unsupported by the evidence or best available science..." which are regulated under the provisions of the Unified Land Development Code, Title 19 MICC.(Exhibit 2)

12. MICC 17.14.010, Section 113.1 and MICC 3.28.020 provide a basis for appeals to the Building Code Board of Appeals on matters related to compliance with Title 17 MICC, Construction Codes. These sections further provide that the board shall have no authority to consider or determine any matter arising under the zoning or land use ordinances.

“MICC Chapter 17.14 Section 113.1 General. In order to hear and decide appeals of orders, decisions or determinations made by the building official relative to the application and interpretation of the construction codes or this administrative code, there shall be a building board of appeals as established in MICC Chapter 3.28.” (Emphasis added).

...

“MICC 3.28.020 Purpose – Function and jurisdiction.

A. The board shall hear all appeals from any notice or order issued, or any action taken, by any administrative officer of the city under the provisions of the construction codes set forth in MICC Title 17; MICC 19.09.080, Moving of buildings; and any code or ordinance wherein it is provided that an appeal to the building board of appeals shall be available; and

B. The board shall have jurisdiction and advisory authority to determine the suitability of alternate materials or alternate types of construction, if an alternate is contemplated or recognized by the express terms of the codes or ordinances of the city; and

C. The board shall have authority to make recommendations to the city council for such new legislation as will expedite or improve the administration of such codes or ordinances; and

D. The board shall have no authority to consider or determine any matter arising under the zoning or land use ordinances.” (Emphasis added.)

III. CONCLUSIONS OF LAW

Based on the above Findings of Facts, the following Conclusions of Law are hereby made:

1. The appeal (Exhibit 2) lacks specificity and information or evidence to support the appeal.
2. Pursuant to MICC 3.28.080, only those matters or issues specifically raised by the appellant shall be considered in the hearing of the appeal.
3. The appeal (Exhibit 2) does not describe an appeal of a decision by the Building Official made pursuant to Title 17 MICC, Construction Codes, and therefore, cannot be heard by the Building Board of Appeals.
4. The Building Board of Appeals shall have no authority to consider or determine any matter arising under the zoning or land use ordinances.
5. Appeals related to Title 19, Unified Land Development Code, shall be heard by the Planning Commission. The appeal of those items related to Title 19 MICC will be scheduled before the Planning Commission.

III. FINDINGS OF FACT/CONCLUSIONS OF LAW

Any finding of fact determined to be a conclusion of law is hereby adopted as such.

IV. DECISION

Based upon the findings of fact contained in the staff report, testimony presented at the Building Code Board of Appeals public hearing and the conclusions of law listed above, the DuBrowa appeal to the Building Code Board of Appeals is hereby denied.

Date 11/8/2016



Jim Stapper
Chair, Building Code Board of Appeals
City of Mercer Island



Craig Burnell
Vice-Chair, Building Code Board of Appeals
City of Mercer Island



DEVELOPMENT SERVICES GROUP

9611 SE 36TH ST., MERCER ISLAND, WA 98040

P: (206) 275-7605 F: (206) 275-7725

www.mercergov.org

July 12, 2017

Four Seasons Homes, LLC
Attn: Paul Maksimchuk
32814 38th Ave S
Federal Way, WA 98001

RE: Notice of In-Completeness for File No. CAO17-007
4634 East Mercer Way, Mercer Island, WA 98040; King County Tax Parcel # 7558700008

Dear Mr. Maksimchuk:

The City of Mercer Island received the above referenced application for critical areas determination on a site located at 4634 East Mercer Way (King County parcel # 7558700008) on June 14, 2017. The City has assigned file number CAO17-007 to the critical areas determination application. Following review of the application, City staff has determined that the application is incomplete and requires the following information prior to issuing a letter of completeness:

1. The application sheet indicates "Applicant requests critical areas determination for alteration of steep slope and steep slope buffer." However, the site plan reflects a watercourse and two possible watercourse buffer configurations; a modification of the watercourse buffer also requires a critical areas determination. No other application material describing the scope of the critical areas determination is provided. *Please clarify the scope of the requested critical areas determination.*
2. It appears that the critical areas determination or subsequent construction may result in alteration of a watercourse buffer area. If the watercourse or buffer area will be altered, it appears that work may occur on lands covered by water, requiring SEPA review. *Please clarify if any construction work will occur within the watercourse buffer area, or if the buffer width will be altered in any way. Please provide a SEPA checklist if work is proposed on lands covered by water.*
3. The site plans do not reflect the location of steep slope hazard areas subject to the proposed alteration. *Please revise the site plans to identify the location of all areas that meet the definition of steep slope.*

Pursuant to Mercer Island City Code 19.15.020(C)(4), if the applicant fails to provide the required information within 90 days from the date of any request for information, the application shall lapse, and become null and void.

Questions particular to a specific discipline may be directed to me by phone at 206-275-7732 or via e-mail at evan.maxim@mercergov.org.

Sincerely,

A handwritten signature in blue ink, appearing to read "Evan Maxim". The signature is fluid and cursive, with a large initial "E" and "M".

Evan Maxim, Planning Manager
City of Mercer Island Development Services Group

PUBLIC NOTICE OF APPLICATION



NOTICE IS HEREBY GIVEN that the City of Mercer Island has received the application described below:

File No: SEP18-021

Description of Request: A request for a SEPA Threshold Determination. The proposed scope of work is construction of a new single-family residence on a vacant lot including a stormwater conveyance crossing a Type 3 watercourse.

Applicant: Paul Maksimchuk, Four Seasons Homes, LLC

Owner: Four Seasons Homes, LLC
Location of Property: 4634 E Mercer, Mercer Island, WA, 98040;
Identified by King County Assessor tax parcel number: 755870-0008

Project Documents: Please follow this file path to access the associated documents for this project: <https://mieplan.mercergov.org/public/CAO17-007/>

Written Comments: **This may be the only opportunity to comment on the environmental impacts of the proposal.** Written comments on this proposal may be submitted to the City of Mercer Island either by email, in person, or by mail to the City of Mercer Island, 9611 SE 36th Street, Mercer Island, WA 98040-3732. Anyone may comment on the application, receive notice, and request a copy of the decision once made. Only those persons who submit written comments or participate at the public hearing (if a hearing is required) will be parties of record; and only parties of record will have the right to appeal.

Public Hearing: Pursuant to MICC 19.15.030 a public hearing is not required for a SEPA Threshold Determination.

Applicable Development Regulations: Applications for a SEPA Threshold Determination are required to be processed as a Type III approval pursuant to Mercer Island City Code (MICC) 19.15.030. Processing requirements for Type 3 approvals are further detailed in MICC 19.15.030. SEPA procedures are contained in 19.07.120.

Other Associated Permits: CAO17-007 and 1507-166REV.

Environmental Documents:

A copy of all studies and / or environmental documents is available through the above project documents link.

Application Process Information:

Date of Application: November 7, 2018
Determined to Be Complete: November 9, 2018
Bulletin Notice: November 13, 2018
Date Mailed: November 13, 2018
Date Posted on Site: November 13, 2018
Comment Period Ends: 5:00PM on December 13, 2018

The project is available for review at the City of Mercer Island, Development Services Group, 9611 SE 36th Street, Mercer Island, Washington.

Project Contact:

Robin Proebsting, Senior Planner
Development Services Group
City of Mercer Island
9611 SE 36th Street
Mercer Island, WA 98040
(206) 275-7717

robin.proebsting@mercergov.org

EAST MERCER RESIDENCE

4634 EAST MERCER WAY,
 MERCER ISLAND, WA 98040

REVISION TO BUILDING PERMIT

CONSULTANT: _____

PROFESSIONAL SEAL: _____

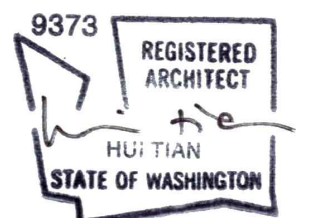

PROJECT: _____

a project for:

 PO BOX 1733 AUBURN, WA 98071
 Phone: (206) 724-1072

EAST MERCER RESIDENCE

4634 EAST MERCER WAY
 MERCER ISLAND, WA 98040

SHEET ISSUE: _____

| DATE | DESCRIPTION |
|------------|--------------------|
| 6/24/2015 | PERMIT SUBMITTAL |
| 8/29/2016 | PERMIT APPROVED |
| 6/05/2017 | REVISION TO PERMIT |
| 05/08/2018 | REVISION TO PERMIT |

MUNICIPALITY REVIEW: _____

PROJECT # MERCER ISLAND 15 - 015

SHEET TITLE: _____

COVERSHEET

PROJECT NO.: 20140904

DATE ISSUED: 05/08/2018

SHEET NUMBER: G0.01

Exhibit 5

ABBREVIATIONS

| | | | | | | | | | | | |
|------------|--|-------|---|---------|--|-------|---|-------|--|---------|----------------------------------|
| AB | ANCHOR BOLT | DEPT | DEPARTMENT | FRZ | FREEZER | LLV | LONG LEG VERTICAL | FLBG | PLUMBING | STD | STANDARD |
| AC | AIR CONDITIONING | DET | DETAIL | FS | FLOOR SINK | LN | LINE | PLF | POUNDS PER LINEAR FOOT | STL | STEEL |
| ACC/ACCESS | ACCESSIBLE | DF | DRINKING FOUNTAIN | FT | FOOT; FEET | LPT | LOW POINT | FLYWD | PLYWOOD | STL_JST | STEEL JOIST |
| ACOUS | ACOUSTICAL | DIA | DIAMETER | FTD | FACIAL TISSUE DISPENSER | LR | LIVING ROOM | PNL | PANEL | STOR | STORAGE |
| AD | AREA DRAIN | DIAG | DIAGONAL | FTG | FOOTING | LT | LIGHT | POL | POLISHED | STRG | STRINGER |
| ADD | ADDITIONAL | DIFF | DIFFUSER | FURN | FURNITURE | LV | LOUVER | PR | PAIR | STRL | STRUCTURAL |
| ADJ | ADJUSTABLE | DIM | DIMENSION | FURR | FURRING; FURRED | PRCST | PREFAB | PROJ | PROJECT | STRUC | STRUCTURAL |
| ADJA | ADJACENT | DIS | DISABLED | FUT | FUTURE | M | MALE; METER | PROP | PROPERTY | SUBCAT | SUBCATEGORY |
| AF | ACCESS FLOORING (RAISED) | DISP | DISPENSER | FWC | FABRIC WALLCOVERING | MACH | MACHINE | PROJ | PROJECT | SURR | SURROUND |
| AFF | ABOVE FINISH FLOOR | DMPF | DAMP/PROOFING | FWP | FABRIC WRAPPED PANE | MAINT | MAINTENANCE | PROP | PROPERTY | SUSP | SUSPENDED |
| AGGR | AGGREGATE | DMT | DEMOUNTABLE | | | MAS | MASONRY | PSF | POUNDS PER SQUARE FOOT | SVC | SERVICE |
| AL | ALUMINUM | DN | DOWN | GA | GAGE | MATL | MATERIAL | PT | POINT; PAINT | SW | SWITCH |
| ALT | ALTER; ALTERNATE | DO | DOOR OPENING | GALV | GALVANIZED | MAX | MAXIMUM | PTD | PAPER TOWEL DISPENSER; PAINTED | SYM | SYMMETRICAL |
| ANCH | ANCHOR | DP | DIMENSION POINT | GB | GRAB BAR | MC | MACHINE BOLT | PTDR | PAPER TOWEL DISPENSER & WASTE RECEPTACLE | SYS | SYSTEM |
| ANOD | ANODIZED | DPTN | DEMOUNTABLE PARTITION | GC | GENERAL CONTRACT(OR) | MBR | MASTER BED ROOM | | | | |
| AP | ACCESS PANEL | DR | DOOR | GFRG | GLASS FIBER REINFORCED CONCRETE | MC | MACHINE BOLT | | | | |
| APC | ACOUSTICAL PANEL CEILING | DRN | DRAIN | | | MDF | MEDIUM DENSITY FIBERBOARD | PTN | PARTITION | T&G | TONGUE & GROOVE |
| APPD | APPROVED | DS | DOWNSPOUT | GFRG | GLASS FIBER REINFORCED GYPSUM | MDO | MEDIUM DENSITY OVERLAY PLYWOOD | PTR | PAPER TOWEL RECEPTACLE | T | TREAD; THERMOSTAT |
| APPROX | APPROXIMATE | DS | DOWNSPOUT | | | | | PTR | PAPER TOWEL RECEPTACLE | TB | TOWEL BAR |
| ARCH | ARCHITECTURAL | DSP | DRY STANK PIPE | | | | | PVC | POLYVINYL CHLORIDE | TBB | TILE BACKER BOARD |
| ATC | ACOUSTICAL TILE CEILING | DW | DISHWASHER | GL | GLUE LAMINATED WOOD | MECH | MECHANICAL | PVMT | PAVEMENT | TC | TOP OF CURB |
| AUTO | AUTOMATIC | DWG | DRAWING | GLU-LAM | GLUE LAMINATED WOOD | MEMB | MEMBRANE | | | TD | TRENCH DRAIN |
| AV | AUDIO VISUAL | DWR | DRAWER | GND | GROUND | MEP | MECHANICAL, ELECTRICAL, PLUMBING | QT | QUARRY TILE | TEL | TELEPHONE; TELECOM |
| | | (E) | EXISTING | GR | GRADE | MET | METAL | QTY | QUANTITY | TEMP | TEMPORARY; TEMPERATURE |
| BD | BOARD | E | EAST | GYP | GYPSUM | MEZ | MEZZANINE | | | TER | TERRAZZO |
| BLDG | BUILDING | EA | EAST | GYP BD | GYPSUM BOARD | MFR | MANUFACTURER | (R) | RELOCATED | TGB | TOGGLE BOLT |
| BLK | BLOCK | EB | EACH | | | MH | MANHOLE | R | RISER; RADIUS | THK | THICK; THICKNESS |
| BLKG | BLOCKING | EB | EXPANSION BOLT | | | MIN | MINIMUM | RA | RETURN AIR | THRES | THRESHOLD |
| BM | BEAM | EC | ELASTOMERIC COATING; EXPOSED CONSTRUCTION | H | HIGH/HEIGHT | MIR | MIRROR | RB | RESILIENT BASE | THRU | THROUGH |
| BO | BOTTOM OF | EFS | EXTERIOR FINISH SYSTEM | HB | HOSE BIBB | MISC | MISCELLANEOUS | RCP | REFLECTED CEILING PLAN | TKBD | TACK BOARD |
| BOH | BACK OF HOUSE | EHS | EXTERIOR INSULATION AND FINISH SYSTEM | HC | HOLLOW CORE | MLDG | MOLDING | RD | ROOF DRAIN | TMPE | TEMPERED |
| BOT | BOTTOM | HDW | HARDWARE | HCP | HANDICAPPED | MM | MILLIMETER | REBAR | REINFORCING BAR | TO | TOP OF |
| BR | BED ROOM | HDWD | HARDWOOD | HDC | HANDICAPPED | MO | MASONRY OPENING | RECOM | RECOMMENDED | TOC | TOP OF CONCRETE |
| BRG | BEARING | HS | HEAT STRENGTHENED (GLASS) | HDM | HOLLOW METAL (STEEL FRAME) | MOD | MODULAR | REC | RECESSED | TOP | TOP OF PAVEMENT |
| BRK | BRICK | ELAS | ELASTOMERIC | HM | HOLLOW METAL (STEEL FRAME) | MR | MOISTURE RESISTANT | REF | REFERENCE | TOS | TOP OF SLAB; TOP OF STRUCTURE |
| BRKT | BRACKET | ELEC | ELECTRICAL | HNDRL | HANDRAIL | MS | MACHINE SCREW | REFL | REFLECTED; REFLECTIVE; REFLECT | TOW | TOP OF WALL |
| BS | BOTH SIDES | ELEV | ELEVATOR | HO | HOLD-OPEN | MNTD | MOUNTED | REFR | REFRIGERATOR | TPD | TOILET PAPER DISPENSER |
| BSMT | BASEMENT | EMER | EMERGENCY | HORLZ | HORIZONTAL | MTG | MOUNTING | REG | REGISTER | TPH | TOILET PAPER HOLDER |
| BTWN | BETWEEN | ENCL | ENCLOSURE | HPT | HIGH POINT | MTG | MOUNTING | REIN | REINFORCED; REINFORCING | TRACT | TRACTION |
| BUR | BUILT-UP ROOFING | EOS | EDGE OF SLAB | HR | HOUR | MUL | MULLION | REL | RELOCATE | TRAN | TRANSITION |
| | | EP | ELECTRICAL PANELBOARD | HRC | HOSE REEL CABINET | MUN | MUNTIN | REM | REMOVABLE | TRD | TREAD |
| CAB | CABINET | EQ | EQUAL | HS | HAND SINK | N | NORTH | REQ | REQUIRE; REQUIRED | TS | TOWEL SHELF |
| CAT | CATEGORY | EQPM | EQUIPMENT | HT | HEIGHT | NA | NOT APPLICABLE | RESIL | RESILIENT | TV | TELEVISION |
| CB | CATCH BASIN | ESCAL | ESCALATOR | HVAC | HEATING, VENTILATING, AIR CONDITIONING | NC | NOISE CRITERIA | REV | REVISION; REVISED | TW | TOP OF WALL |
| CBU | CEMENTITIOUS BACKER UNIT | EW | EACH WAY | HW | HOT WATER | NIC | NOT IN CONTRACT | RGH | ROUGH | TYP | TYPICAL |
| CEM | CEMENT | EXH | EXHAUST | NO | NOISE CRITERIA | NOM | NOMINAL | RH | RIGHT HAND; ROBE HOOK | UC | UNDERCUT |
| CEM PLAS | CEMENT PLASTER | EXP | EXPANSION | INS | INSIDE DIAMETER (DIMENSION) | NTS | NOT TO SCALE | RM | ROOM | UL | UNDERWRITERS LABORATORY |
| CER | CERAMIC | EXPO | EXPOSED | IN | INCH | OA | OVERALL | RND | ROUND | UNF | UNFINISHED |
| CFCI | CONTRACTOR FURNISHED, CONTRACTOR INSTALLED | EXST | EXISTING | INCAND | INCANDESCENT | OBS | OBSOLETE | RO | ROUGH OPENING | UN | UNLESS OTHERWISE NOTED |
| | | EXT | EXTERIOR | INCL | INCLUDING; INCLUDED; INCLUDING | OC | ON CENTER | RTG | RATED | UR | URINAL |
| CG | CHILLER | | | INCL | INCLUDING; INCLUDED; INCLUDING | OCEW | ON CENTER EACH WAY | RWC | RAIN WATER CONDUCTOR | VAC | VENTILATION AND AIR CONDITIONING |
| CHAN | CHANNEL | F | FEMALE | INFO | INFORMATION | OD | OUTSIDE DIAMETER; DIMENSION | RWL | RAIN WATER LEADER | VCT | VINYL COMPOSITION TILE |
| CI | CAST IRON | FA | FIRE ALARM | INSUL | INSULATION | S | SOUTH | VCT | VENT | VERT | VERTICAL |
| CIP | CAST-IN-PLACE | FAB | FABRICATE | INT | INTERIOR | SA | SUPPLY AIR | VEST | VESTIBULE | VIF | VERIFY IN FIELD |
| CJ | CONTROL JOINT; CONSTRUCTION JOINT | FB | FLAT BAR | INTEG | INTEGRATED | SAN | SANITARY | VOL | VOLUME | VP | VENER PLASTER |
| | | FCU | FAN COIL UNIT | INTERM | INTERMEDIATE | SCD | SEAT COVER DISPENSER | VOL | VOLUME | VR | VAPOR RETARDER |
| CL | CENTER LINE | FD | FLOOR DRAIN | INV | INVERT | SC | SOLID CORE | VOL | VOLUME | VT | VINYL TILE |
| CLG | CEILING | FDC | FIRE DEPARTMENT CONNECTION | IPS | INTERNATIONAL PIPE STANDARD | SCD | SEAT COVER DISPENSER | VOL | VOLUME | VTR | VENT THROUGH ROOF |
| CLO | CLOSET | IRMA | FOUNDATION | | | SCHE | SCHEDULE | VP | VENER PLASTER | VWC | VINYL WALL COVERING |
| CLR | CLEAR | IRMA | FOUNDATION | | | SCR | SCREEN | VR | VAPOR RETARDER | | |
| CMU | CONCRETE MASONRY UNIT | FE | FIRE EXTINGUISHER | | | SD | STORM DRAIN; SMOKE DETECTOR; SOAP DISPENSER SECTION | VT | VINYL TILE | | |
| CNR | COUNTER | FEC | FIRE EXTINGUISHER CABINET | | | SHR | SHOWER | VTR | VENT THROUGH ROOF | | |
| CO | CASED OPENING; CLEANOUT | FF&E | FURNITURE, FINISHES & EQUIPMENT | JAL | JALOUSIE | OPH | OPPOSITE HAND | WVC | WATERPROOFING | | |
| COL | COLUMN | | | JAN | JANITOR | OPNG | OPENING | | | WD | WOOD |
| COMP | COMPARTMENT | FFEL | FINISH FLOOR ELEVATION | JAN | JANITOR | OPP | OPPOSITE | WDS | WOOD SCREW | WDW | WINDOW |
| CONC | CONCRETE | FH | FLAT HEAD | JB | JUNCTION BOX | OPR | OPERABLE | WGL | WIRE GLASS | WH | WHERE OCCURS |
| COND | CONDITION | FHC | FIRE HOSE CABINET | JC | JANITOR'S CLOSET | OPR | OPERABLE | WO | WHERE OCCURS | WP | WATERPROOFING |
| CONN | CONNECTION | FIN | FINISH | JST | JOIST | ORD | OVERFLOW ROOF DRAIN | WPT | WORK POINT | WRF | WATER RESISTANT; REPELLANT |
| CONSTR | CONSTRUCTION | FIXT | FIXTURE | JT | JOINT | OVHD | OVERHEAD | WS | WEATHER STRIPPING | WSCOT | WAINSCOT |
| CONT | CONTINUOUS | FL | FLOOR | | | | | WSP | WET STAND PIPE | WT | WEIGHT |
| CONTR | CONTRACTOR | FLASH | FLASHING | K | KIP (1000 LBF) | P | PAINT | WTT | WALL TO WALL | WW | WALL TO WALL |
| COORD | COORDINATE | KD | KNOCK DOWN | KD | KNOCK DOWN | PA | PUBLIC ADDRESS SYSTEM | WTF | WELDED WIRE FABRIC | | |
| CORR | CORRIDOR | KIT | KITCHEN | KIT | KITCHEN | PARTN | PARTITION | | | | |
| CRT | CARPET | KPL | KICK PLATE | KPL | KICK PLATE | PASS | PASSAGE | | | | |
| CRM | CONCRETE RUBBLE MASONRY | KG | KILOGRAM | KG | KILOGRAM | PAVD | PAPER TOWEL DISPENSER | | | | |
| CT | CERAMIC TILE; COOLING TOWER | KO | KNOCKOUT | KO | KNOCKOUT | PAV | PAVING | | | | |
| | | FOC | FACE OF CONCRETE | | | PBD | PARTICLEBOARD | | | | |
| | | FOF | FACE OF FINISH | L | LONG OR LITER (METRIC DOCS) | SND | SANITARY NAPKIN DISPENSER | | | | |
| CTR | CENTER | FOM | FACE OF MASONRY | | | SDR | SANITARY NAPKIN RECEPTACLE | | | | |
| CTSK | COUNTERSUNK | FOS | FACE OF STUDS; SLAB; STRUCTURE | LAB | LABORATORY | PDF | POWDER DRIVEN FASTENER | SP | SPECIFICATION | SPK | SPRINKLER |
| CULT | CULTURED | LAM | LAMINATE; LAMINATION | LAV | LAVATORY | PERF | PERFORATED | SPEC | SPECIFICATION | SPR | SPRINKLER |
| CW | COLD WATER (PIPING) | LAV | LAVATORY | LAV | LAVATORY | PERIM | PERIMETER | SPKR | SPRINKLER | WSP | WET STAND PIPE |
| | | FP | FIRE PROTECTION | LB | POUND | PERP | PERPENDICULAR | SQ | SQUARE | WT | WEIGHT |
| | | FPG | FIREPROOFING | LDG | LANDING | PH | PENITHOUSE | SSE | STRUCTURE SLAB ELEVATION | WW | WALL TO WALL |
| D | DEEP; DEPTH; DRYER | FR | FRAME | LF | LINEAR FOOT | PI | POINT OF INTERSECTION | SS | STAINLESS STEEL | WWF | WELDED WIRE FABRIC |
| DA | DOUBLE ACTING | FRP | FIBERGLASS REINFORCED POLYESTER | LH | LEFT HAND | PL | PLATE; PROPERTY LINE | SS | STAINLESS STEEL | | |
| DBL | DOUBLE | FRT | FIRE RETARDANT TREATED | LKR | LOCKER | PLAM | PLASTIC LAMINATE | SSK | SERVICE SINK | | |
| DD | DECK DRAIN | FRTW | FIRE RETARDANT TREATED WOOD | LLH | LONG LEG HORIZONTAL | PLAS | PLASTER | STA | STATION | | |
| DEG | DEGREE | | | | | | | | | | |
| DEMO | DEMOLITION | | | | | | | | | | |

SYMBOLS

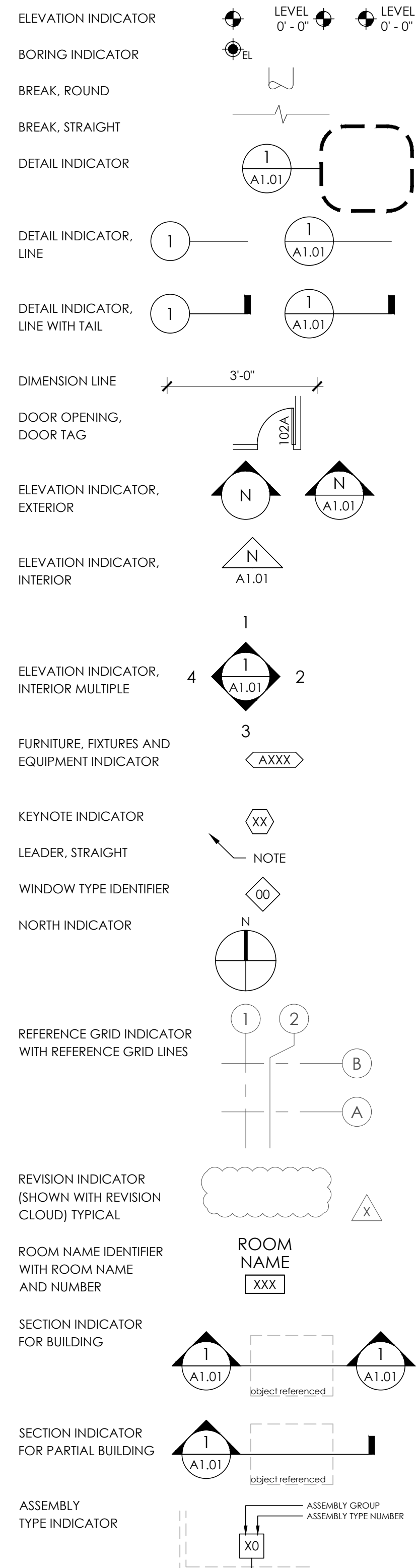

PROJECT TEAM

OWNER
 BARCELO HOMES
 32505 138TH PLACE SE
 AUBURN, WA 98092
 CONTACT: BOGDAN MAKSIMCHUK
 EMAIL: bogdan@barcelohomes.com
 PHONE: 206-724-1072

GEOTECHNICAL ENGINEER
 PANGE
 3213 EASTLAKE AVENUE E, SUITE B
 SEATTLE, WA 98102-7127
 CONTACT: H. MICHAEL XUE, P.E.
 EMAIL: mxue@pangeo.com
 PHONE: 206-262-0370

STRUCTURAL ENGINEER
 TECINSTRUCT LLC
 6830 NE BOTHELL WAY
 SUITE C, PMB 181
 KENMORE, WA 98028
 CONTACT: ROLAND HEIMISCH
 EMAIL: rheimsch@yahoo.com
 PHONE: 206-553-9076

ARCHITECT
 STUDIO19 ARCHITECTS
 207 1/2 1ST AVE S, SUITE 300
 SEATTLE, WA 98104
 CONTACT: ANDREW WISDOM
 EMAIL: awisdom@studio19architects.com
 PHONE: 206-466-1225

CIVIL ENGINEERS & LAND SURVEYORS
 LITCHFIELD ENGINEERING, LLC
 12840 - 81ST AVENUE NE
 KIRKLAND, WA 98034
 CONTACT: KEITH LITCHFIELD, P.E.
 EMAIL: ka.litchfield@frontier.com
 PHONE: 425-821-5038

CONTRACTOR
 BARCELO HOMES
 32505 138TH PLACE SE
 AUBURN, WA 98092
 CONTACT: BOGDAN MAKSIMCHUK
 EMAIL: bogdan@barcelohomes.com
 PHONE: 206-724-1072

DRAWING INDEX

| GENERAL | COVERSHEET |
|----------------------|---|
| G0.00 | COVERSHEET |
| G1.01 | CODE SUMMARY |
| SURVEY | |
| 1 OF 2 | TREE & TOPOGRAPHIC SURVEY & GENERAL NOTES |
| 2 OF 2 | TREE & TOPOGRAPHIC SURVEY |
| CIVIL | |
| C1 | COVER SHEET, VICINITY MAP, GENERAL NOTES |
| C2 | TEC PLAN, MISC., DETAILS, EROSION CONTROL NOTES |
| C3 | TIE IMPROVEMENT PLAN & NOTES |
| C4 | CONSTRUCTION DETAILS |
| C5 | TEMPORARY EXCAVATION PLAN |
| C6 | STORM DRAIN OUTFALL |
| ARCHITECTURAL | |
| A1.01 | SITE PLAN |
| A1.02 | TREE PLAN |
| A2.01 | LEVEL 1 FLOOR PLAN |
| A2.01.1 | LEVEL 1 DIMENSION PLAN |
| A2.02 | LEVEL 2 FLOOR PLAN |
| A2.02.1 | LEVEL 2 DIMENSION PLAN |
| A2.03 | LEVEL 3 FLOOR PLAN |
| A2.03.1 | LEVEL 3 DIMENSION PLAN |
| A2.04 | ROOF PLAN |
| A3.01 | NORTH ELEVATION |
| A3.02 | EAST ELEVATION |
| A3.03 | SOUTH ELEVATION |
| A3.04 | WEST ELEVATION |
| A4.01 | BUILDING SECTION |
| A4.02 | BUILDING SECTION |
| A4.03 | BUILDING SECTION |
| A4.04 | BUILDING SECTION |
| A8.01 | DETAILS |
| A8.02 | DETAILS |
| A9.01 | DOOR & WINDOW SCHEDULES |
| A9.02 | DOOR & WINDOW SCHEDULES |
| A9.03 | DOOR & WINDOW SCHEDULES |
| STRUCTURAL | |
| S1 | GENERAL STRUCTURAL NOTES |
| S1.1 | STATEMENT OF SPECIAL INSPECTIONS |
| S2 | FOUNDATION PLAN |
| S2.1 | RETAINING WALL SCHEDULE |
| S3 | MOMENT FRAME DETAILS & ELEVATION |
| S4 | FIRST FLOOR FRAMING PLAN |
| S5 | SECOND FLOOR FRAMING PLAN |
| S6 | WALL & BUILDING SECTIONS, DETAILS |
| S7 | ROOF FRAMING PLAN |
| S8 | FIRST FLOOR SHEAR WALL PLAN |
| S9 | SECOND & THIRD FLOOR SHEAR WALL PLANS |
| S10 | SOLDIER PILE SHORING |
| S11 | SOLDIER PILE SHORING |

ZONING CODE ANALYSIS

CODE REFERENCES:
 MERCER ISLAND MUNICIPAL CODE, ADOPTED DECEMBER 1, 2014
 2012 INTERNATIONAL BUILDING CODE WITH STATEWIDE AND CITY AMENDMENTS
 2012 INTERNATIONAL RESIDENTIAL CODE WITH STATEWIDE AND CITY AMENDMENTS
 2012 SEATTLE ENERGY CODE - RESIDENTIAL
 2012 INTERNATIONAL MECHANICAL CODE WITH STATEWIDE AND CITY AMENDMENTS
 WASHINGTON CITIES ELECTRICAL CODE
 2012 INTERNATIONAL FIRE CODE WITH STATEWIDE AND CITY AMENDMENTS
 2012 INTERNATIONAL FUEL GAS CODE WITH STATEWIDE AND CITY AMENDMENTS
 2012 WASHINGTON STATE PLUMBING CODE WITH CITY AMENDMENTS

| SECTION | EXISTING / REQUIRED | PROPOSED | COMPLIES | SHEET |
|-----------------------------|---|---------------------------------|----------|---------------|
| ZONING | R-15 | R-15 | YES | G0.02 |
| LOT SIZE | 21,417.54 SF STEEP SLOPE | | | G0.02 |
| CRITICAL AREAS | HILLSIDE (27.71 % MAX SLOPE) | | | A1.01 |
| MAXIMUM BUILDABLE AREA | 45% OF LOT AREA (21,417 SF) = 9,637.65 SF | 9,637.65 SF | YES | G0.02 |
| MAXIMUM IMPERVIOUS COVERAGE | 30% OF LOT AREA (21,417 SF) = 6,425.10 SF | - | - | G0.02 |
| BUILDING HEIGHT LIMIT | 30' FROM AVERAGE BUILDING GRADE + 5' FOR ROOF WITH MINIMUM 4:12 PITCH FRONT = 20' MINIMUM | 30' | YES | A3.01 / A3.02 |
| SETBACKS | REAR = 25' MINIMUM | 25' | YES | A1.01 |
| | SIDES = 5' MINIMUM | 5' | YES | A1.01 |
| PARKING | 1 PARKING SPACE / DWELLING UNIT | 1 PARKING SPACE / DWELLING UNIT | YES | A2.01 |
| PARKING ACCESS | ACCESS FROM PRIVATE ROAD | 10 FT DRIVE | YES | A2.01 |
| LANDSCAPING | TOTAL DIAMETER OF TREES RETAINED OR PLANTED = 2 INCH PER 1000 SF | 1 | YES | A1.01 |
| FIRE SPRINKLERS | PER NFPA 13D - REQUIRED ON STRUCTURES 5,000 SF OR MORE | YES | YES | DEFERED |
| PROJECTIONS | 36" ROOF EAVES AND GUTTERS | | YES | A2.04 |
| CONSTRUCTION TYPE | RESIDENTIAL - TYPE VA | | | |
| WATER | WATER DISTRICT | | | |
| SEWER / SEPTIC | PUBLIC | | | |
| ROAD ACCESS | PRIVATE | | | |
| STREET SURFACE | PAVED | | | |

ENERGY CODE ANALYSIS

| PERFORMANCE REQUIREMENT | MEET OR EXCEED THE 2012 WASHINGTON STATE ENERGY CODE | PROPOSED |
|---|--|-----------------------------|
| TOTAL HEATED FLOOR AREA (GROSS) | | 3,017.01 SF |
| LEVEL 1 | | 1,394 SF |
| LEVEL 2 | | 976.21 SF |
| LEVEL 3 | | 646.80 |
| GLAZING AREA % OF FLOOR | OPTION III : UNLIMITED | 1,310.67 SF |
| CLIMATE ZONE | MARINE 4 | |
| FENESTRATION U-FACTOR | 0.30 | SEE WSEC GLAZING SCHEDULE |
| CEILING R-VALUE | R-49 OR R-38 ADVANCED FRAMED CEILING | R-50 & R-54 (SEE ROOF PLAN) |
| WOOD FRAME WALL ABOVE GRADE R-VALUE | R-21 (16 OC, HEADERS MIN R-10) | R-21 |
| FLOOR R-VALUE / U-FACTOR | R = 30 / U = 0.029 | R-30 |
| SLAB ON GRADE R-VALUE | R = 10, 2' | R-10 (FULL UNDER) |
| BELOW GRADE U-FACTOR | 0.042 | |
| DOOR U-FACTOR | 0.20 | |
| DOOR U-FACTOR (DEFAULT GLAZED FENESTRATION U-FACTOR, METAL WITH THERMAL BREAK, DOUBLE PANE, TABLE R303.1.3 (1)) | 0.65 | NOT APPLICABLE |

CONTRACTOR NOTES

- GENERAL CONTRACTOR SHALL BE RESPONSIBLE FOR ANY AND ALL BONDS, CASH DEPOSITS, ETC. THAT THE CITY WILL REQUIRED TO FACILITATE CONSTRUCTION OF THE PROJECT.
- GENERAL CONTRACTOR WILL BE RESPONSIBLE TO PROVIDE WATER, SEWER, POWER AND TELEPHONE CONNECTIONS FOR THE CONSTRUCTION TRAILER.
- UNLESS QUALIFIED, NO PRODUCT SUBSTITUTIONS "OR EQUAL" PRODUCTS, EQUIPMENT OR MATERIALS SHALL BE ALLOWED.
- THE GENERAL CONTRACTOR SHALL OBTAIN AND PAY FOR ALL OTHER PERMITS REQUIRED BY LAW FOR THE EXECUTION OF THIS WORK UNLESS NOTED OTHERWISE. THE BASIC BUILDING PERMIT WILL BE OBTAINED AND PAID FOR BY THE OWNER. ALL TRADE PERMITS, IF REQUIRED BY JURISDICTION AUTHORITIES, AND FEES SHALL BE PAID FOR BY THE GENERAL CONTRACTOR. THE GENERAL CONTRACTOR SHALL ALSO OBTAIN AND PAY CERTIFICATES, INSPECTIONS AND OTHER LEGAL FEES REQUIRED, BOTH PERMANENT AND TEMPORARY, INCLUDING PLUMBING, ELECTRICAL AND HIGHWAY PERMITS UNLESS SPECIFICALLY OTHERWISE PROVIDED.
- GENERAL CONTRACTOR HAS RESEARCHED AND VERIFIED ALL TRASH, DEBRIS, AND RECYCLING REQUIREMENTS FOR THE CITY IN WHICH THIS WORK WILL BE PERFORMED AND HAS INCLUDED SUCH COSTS INTO THIS PROPOSAL.
- GENERAL CONTRACTOR IS RESPONSIBLE FOR SITE SURVEYING AND LAYOUT, OWNER TO PROVIDE ONE (1) BENCHMARK FOR GENERAL CONTRACTOR'S USE.
- IT IS THE RESPONSIBILITY OF THE GENERAL CONTRACTOR TO COORDINATE, FURNISH AND INSTALL ALL FRAMING, BACKING AND DEADWOOD REQUIREMENTS FOR EQUIPMENT AND MATERIALS INSTALLED IN THE BUILDING.
- JOINT SEALERS SHALL BE REQUIRED AT THE INTERSECTION OF ALL DISSIMILAR MATERIALS IN INTERIOR AND EXTERIOR CONDITIONS.
- ARCHITECTURAL, MECHANICAL, AND ELECTRICAL PENETRATIONS OF THE BUILDING ENVELOPE INCLUDING EXTERIOR WINDOWS, GRILLES, HVAC DUCTWORK, AND CONDUIT AS REQUIRED THROUGH THE EXTERIOR WALLS, ROOF DECKS, VERTICAL ROOF AND MANSARD WALLS SHALL REQUIRE MECHANICAL FLASHING IN ADDITION TO APPROPRIATE EXTERIOR SEALANTS TO PROVIDE AND ENSURE WATERTIGHT CONDITIONS AT THESE LOCATIONS.
- GUTTERS, DOWNSPOUTS AND ALL EXTERIOR SHEET METALS ARE TO BE PRE-FINISHED AT THE FACTORY. COLOR SHALL BE SELECTED FROM THE MANUFACTURER'S FULL RANGE OF COLOR OPTIONS BY THE ARCHITECT. NO FIELD PAINTING TO BE ALLOWED.
- ALL EXTERIOR LOUVER GRILLES SHALL BE FACTORY PAINTED WITH KYNAR FINISH TO MATCH THE EXTERIOR FIELD COLOR IN WHICH THEY ARE LOCATED.
- ALL EXTERIOR METALS SHALL BE GALVANIZED, PRE-FINISHED OR FIELD PAINTED PER ARCHITECT COORDINATION GC SHALL ASSUME THE MOST STRINGENT FINISH IF NOT INDICATED ON DOCUMENTS.
- APPLIANCES - GENERALLY, THIS EQUIPMENT IS DELIVERED FACTORY DIRECT MOUNTINGS AND CONNECTIONS NOT INCLUDED. GENERAL CONTRACTOR SHALL MOUNT AND MAKE UP ALL REQUIRED CONNECTIONS TO MAKE THE EQUIPMENT FUNCTION PROPERLY.
- GENERAL CONTRACTOR IS RESPONSIBLE FOR PROVIDING A COMPLETE SET OF DRAWINGS TO EACH SUBCONTRACTOR AND FOR INSURING THAT THE WORK OF EACH SUBCONTRACTOR IS COORDINATED WITH THE WORK OF ALL OTHER SUBCONTRACTORS.
- THE LAST DATED REVISION VOIDS AND SUPERSEDES ANY AND ALL PREVIOUS DRAWINGS WITH THE SAME SHEET NUMBER. IT IS THE RESPONSIBILITY OF THE GENERAL CONTRACTOR TO RECOVER AND DISPOSE OF ALL SUPERSEDED / PREVIOUSLY ISSUED PLANS FROM ALL SUBCONTRACTORS, SUPPLIES AND MATERIAL PERSONS. ALL COSTS RESULTING FROM A FAILURE TO ISSUE REVISED SHEETS, AND RECOVERY / DISPOSAL OF SUPERSEDED SHEETS IN A TIMELY MANNER, SHALL BE ABSORBED BY THE GENERAL CONTRACTOR. THE OWNER AND ARCHITECT WILL NOT BE RESPONSIBLE FOR ANY COSTS ASSOCIATED WITH THE ABOVE.
- GENERAL CONTRACTOR SHALL BE RESPONSIBLE TO LOCATE ALL EXISTING UTILITIES AND PROTECT THEM FROM DAMAGE. THE CONTRACTOR SHALL BEAR ALL EXPENSES OF REPAIR OR REPLACEMENT OF UTILITIES OR OTHER PROPERTY DAMAGED BY OPERATIONS IN CONJUNCTION WITH THE EXECUTION OF THE WORK. ALL FINAL CONNECTIONS TO EXISTING UTILITIES SHALL BE BY THE CONTRACTOR.
- GENERAL CONTRACTOR SHALL BE RESPONSIBLE FOR THE SECURITY OF THE SITE THROUGHOUT THE CONSTRUCTION PROCESS.
- GENERAL CONTRACTOR SHALL TAKE ALL NECESSARY PRECAUTIONS TO ENSURE THE SAFETY OF THE OCCUPANTS AND WORKERS AS REQUIRED BY GENERAL CONDITIONS AND ALL APPLICABLE LOCAL, STATE, AND FEDERAL REGULATIONS. DO NOT OBSTRUCT STREETS, SIDEWALKS, ALLEYS OR OTHER RIGHT-OF-WAYS WITHOUT FIRST OBTAINING PROPER PERMITS.
- ALL FIRE RATED CONSTRUCTION SHALL CONFORM WITH CURRENT UL TESTED STANDARD AND/OR LOCAL REQUIREMENTS.

GENERAL NOTES

- DO NOT SCALE DRAWINGS. WRITTEN DIMENSIONS TAKE PRECEDENCE.
- DRAWINGS HAVE BEEN PREPARED ON AN ORIGINAL SHEET SIZE OF 24" X 36".
- INFORMATION REGARDING EXISTING CONDITIONS USED TO PREPARE THESE DRAWINGS HAS BEEN PROVIDED BY OTHERS. CONTRACTOR TO FIELD VERIFY EXISTING CONDITIONS PRIOR TO COMMENCING CONSTRUCTION. PROVIDE WRITTEN NOTIFICATION TO THE ARCHITECT OF ANY DISCREPANCIES BETWEEN EXISTING CONDITIONS AND THE DRAWINGS. THE ARCHITECT WILL ISSUE A WRITTEN DIRECTIVE IF FURTHER CLARIFICATION IS REQUIRED.
- CONTRACTOR TO FIELD VERIFY ALL DIMENSIONS, DATUM, LEVELS AND CONDITIONS PERTAINING TO THE WORK PRIOR TO COMMENCING CONSTRUCTION. PROVIDE WRITTEN NOTIFICATION TO THE ARCHITECT OF ANY DISCREPANCIES WITH THE DOCUMENTS. THE ARCHITECT WILL ISSUE A WRITTEN DIRECTIVE IF FURTHER CLARIFICATION IS REQUIRED.
- THESE DRAWINGS ARE THE EXCLUSIVE PROPERTY OF STUDIO19 ARCHITECTS, AND HAVE BEEN PREPARED FOR THE USE IN THE EXECUTION OF THE ENCLOSED PROJECT. USE OR REPRODUCTION FOR ANY OTHER PURPOSE WITHOUT THE WRITTEN PERMISSION OF STUDIO19 ARCHITECTS IS PROHIBITED.
- LEGENDS ON THE PLANS AND SCHEDULE IN THE SPECS SHALL BE COMPLEMENTARY.
- ALL CONSTRUCTION SHALL COMPLY WITH APPLICABLE CODES AND RESTRICTIONS ENFORCED BY AUTHORITIES HAVING JURISDICTION.

VENTILATION NOTES

- WAC 51-13, WASHINGTON STATE VENTILATION AND INDOOR AIR QUALITY CODE SEATTLE RESIDENTIAL CODE (SRC), CHAPTER 15
- WHOLE HOUSE VENTILATION PER IRC M1508.7.
 - NOISE: WHOLE HOUSE FANS LOCATED FOUR FEET OR LESS FROM THE INTERIOR GRILLE SHALL HAVE A SONE RATING OF 1.0 OR LESS.
 - EXHAUST DUCTS SHALL TERMINATE OUTSIDE OF THE BUILDING.
 - OUTDOOR AIR DISTRIBUTION: OUTDOOR AIR SHALL BE DISTRIBUTED TO EACH HABITABLE ROOM BY MEANS SUCH AS INDIVIDUAL INLETS, SEPARATE DUCT SYSTEMS, OR A FORCED-AIR SYSTEM.
 - DOORS SHALL BE UNDERCUT TO A MINIMUM OF ONE-HALF INCH ABOVE THE SURFACE OF THE FINISH FLOOR COVERING. DOORS AND OPERABLE LITES IN WINDOWS ARE DEEMED NOT TO MEET THE OUTDOOR AIR SUPPLY INTAKE REQUIREMENTS.
 - INTERMITTENTLY OPERATING MINIMUM EXHAUST RATES FOR BATHROOMS = 50 CFM, KITCHENS = 100 CFM. - U.N.O.
 - EXHAUST HOOD SYSTEMS CAPABLE OF EXHAUSTING IN EXCESS OF 400 CFM SHALL BE PROVIDED WITH MAKEUP AIR AT A RATE APPROXIMATELY EQUAL TO THE EXHAUST AIR RATE. SUCH MAKEUP AIR SYSTEMS SHALL BE EQUIPPED WITH A MEANS OF CLOSURE AND SHALL BE AUTOMATICALLY CONTROLLED TO START AND OPERATE SIMULTANEOUSLY WITH THE EXHAUST SYSTEM. PER M1503.4

ENERGY CODE NOTES

- WASHINGTON STATE ENERGY CODE
- BUILDING AIR LEAKAGE TESTING, DEMONSTRATING 2.0 AIR EXCHANGES PER HOUR (MAX) IS REQUIRED PRIOR TO FINAL INSPECTION. THE TEST RESULTS SHALL BE POSTED ON THE RESIDENTIAL ENERGY COMPLIANCE CERTIFICATE.
 - EACH DWELLING UNIT IS REQUIRED TO BE PROVIDED WITH AT LEAST ONE PROGRAMMABLE THERMOSTAT FOR REGULATION OF TEMPERATURE (WSEC R403.1.1).
 - A SIGNED AFFIDAVIT DOCUMENTING THE DUCT LEAKAGE TEST RESULTS SHALL BE PROVIDED TO THE BUILDING INSPECTOR PRIOR TO AN APPROVED FINAL INSPECTION (WSEC R402.4.1.2).
 - DUCT LEAKAGE TEST RESULTS SHALL BE PROVIDED TO THE BUILDING INSPECTOR AND HOMEOWNER PRIOR TO APPROVED FINAL INSPECTION (WSEC R403.2.2 AND WSU RS-33).
 - MINIMUM 75% OF ALL INTERIOR LUMINAIRES SHALL BE HIGH EFFICACY LUMINAIRES, AND ALL EXTERIOR LIGHTING SHALL BE HIGH EFFICACY LUMINAIRES (WSEC R404.1).
 - ALL HEADERS IN EXTERIOR WALLS TO HAVE A MINIMUM R-10 INSULATION.
 - ALL DUCTS NOT LOCATED COMPLETELY INSIDE THE BUILDING THERMAL ENVELOPE SHALL BE INSULATED TO A MINIMUM OF R-8.
 - REQUIRED SLAB PERIMETER INSULATION TO BE WATER RESISTANT MATERIAL, MANUFACTURED FOR ITS INTENDED USE, AND INSTALLED ACCORDING TO MANUFACTURER'S SPECIFICATIONS. FOR SLABS INSIDE FOUNDATION WALL, THE INSULATION SHALL BE INSTALLED TO PROVIDE A THERMAL BREAK BETWEEN THE SLAB EDGE AND THE FOUNDATION. MONOLITHIC SLABS SHALL INCLUDE INSULATION, INSTALLED OUTSIDE THE FOUNDATION WALL, AND SHALL EXTEND DOWNWARD FROM THE TOP OF THE SLAB FOR A MINIMUM DISTANCE OF 24" OR DOWNWARD AND THEN HORIZONTALLY FOR A MINIMUM COMBINED DISTANCE OF 24". AND SHOULD INCLUDE R-10 INSULATION UNDER THE NON-LOAD BEARING PORTIONS OF THE SLAB.
 - INSULATION FOR HOT WATER PIPES SHALL BE A MINIMUM OF R-4.
 - WASHINGTON STATE ENERGY CREDITS PER TABLE 406.2:
 - EFFICIENT BUILDING ENVELOPE PRESCRIPTIVE COMPLIANCE BASED ON TABLE R402.1 WITH THE FOLLOWING MODIFICATIONS:
 FENESTRATION U = 0.28
 SLAB ON GRADE, R-10 PERIMETER AND UNDER ENTIRE SLAB BELOW GRADE SLAB R-10 PERIMETER AND UNDER ENTIRE SLAB OR COMPLIANCE BASED ON SECTION R402.1.4: REDUCE TOTAL UA BY 5% CREDITS FROM THIS OPTION = 0.5
 - AIR LEAKAGE CONTROL AND EFFICIENT VENTILATION COMPLIANCE BASED ON SECTION R402.4.1.2 REDUCE TESTED AIR LEAKAGE TO 2.0 AIR CHANGES PER HOUR MAX, AND ALL WHOLE HOUSE VENTILATION REQUIREMENTS AS DETERMINED BY SECTION M1507.3 OF THE IRC.

 PROVIDE BALANCED WHOLE HOUSE VENTILATION SYSTEM WITH MINIMUM SENSIBLE HEAT RECOVERY EFFICIENCY OF 0.70 PER WSEC R403.5 CREDITS FROM THIS OPTION = 1.0
 - EFFICIENT WATER HEATING GAS, PROPANE, OR OIL WATER HEATER WITH MINIMUM EF OF 0.62 CREDITS FROM THIS OPTION = 0.5

VICINITY MAP

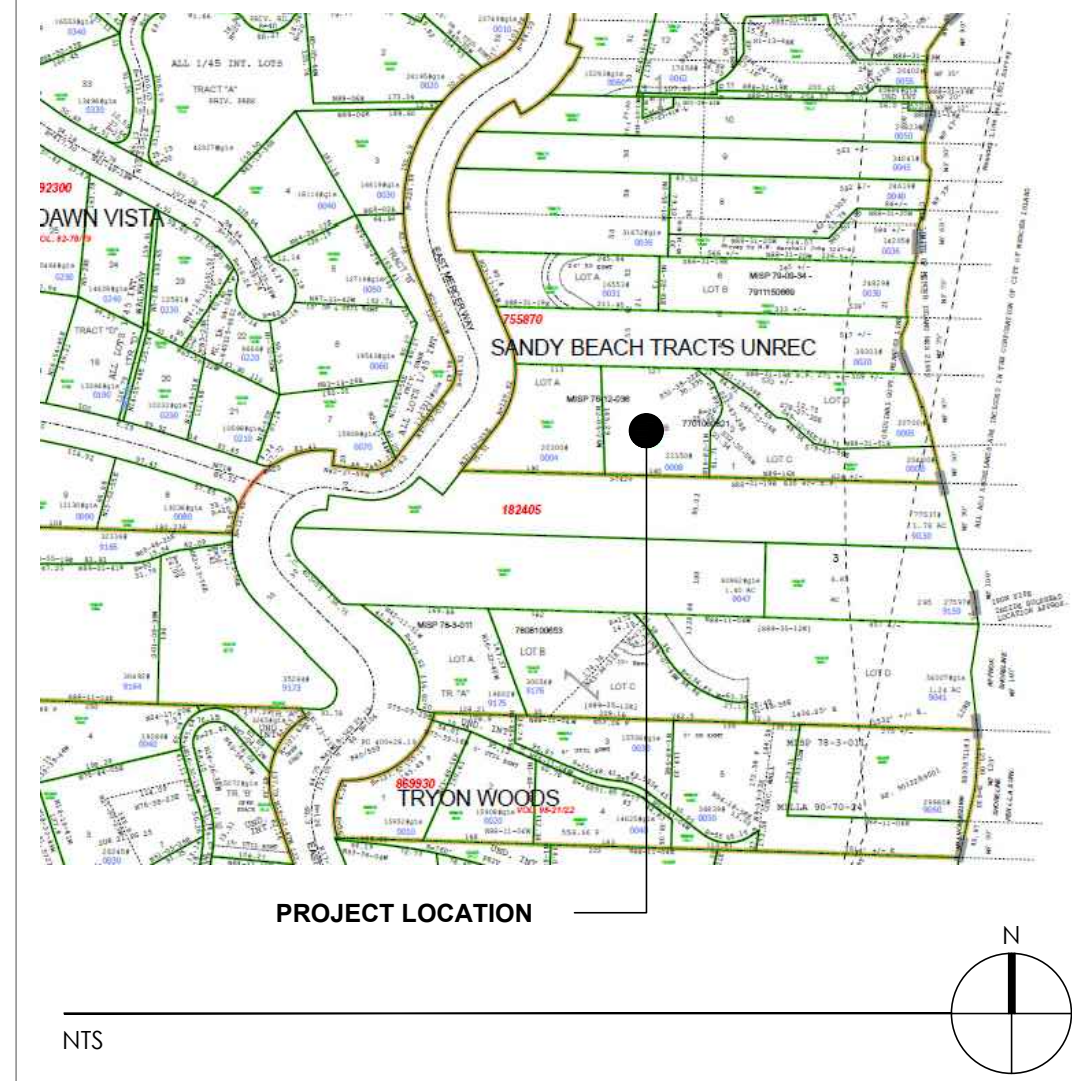

SITE DESCRIPTION

PARCEL # 755870-0008
 LEGAL DESCRIPTION SANDY BEACH TRS UNREC LOT B CITY OF MERCER ISLAND SHORT PLAT 76-12-036 REC #7701060821 SD SP DAF - LOTS 1-2 & 3
 PROPERTY ADDRESS: 4634 EAST MERCER WAY, MERCER ISLAND, WA 98040
 LOT SIZE 21,417.54 GSF PER SURVEY
 WIDTH 159.65'
 DEPTH 145.19'
 WATERFRONT NONE
 ACCESS PRIVATE ROAD FROM EAST MERCER WAY
 EASEMENTS ACCESS EASEMENT AS DEFINED IN SHORT PLAT 76-12-036 REC#7701060821

PROJECT INFORMATION

PROJECT DESCRIPTION: A NEW CONSTRUCTION OF A 3 LEVEL SINGLE FAMILY RESIDENCE
 PROPERTY ADDRESS: 4634 EAST MERCER WAY, MERCER ISLAND, WA 98040
 SEISMIC ZONE: ZONE 3
 PARCEL #: 755870-0008
 LOT AREA: 21,417.54 GSF PER SURVEY
 BUILDING AREAS:
 LEVEL 1: 1,716 SQ FT
 LEVEL 2: 2,408 SQ FT
 LEVEL 3: 2,364 SQ FT
 TOTAL LIVABLE AREA: 6,488 SQ FT
 F.A.R. 30.29 %
 LEVEL 1 GARAGE: 898 SQ FT
 LEVEL 2 VIEW DECK 1: 431 SQ FT
 LEVEL 2 VIEW DECK 2: 217 SQ FT
 LEVEL 3 VIEW DECK 3: 148 SQ FT
 LEVEL 3 ROOF DECK: 262 SQ FT
 TOTAL STRUCTURE SF: 8,444 SQ FT
 IMPERVIOUS AREAS:
 STRUCTURE FOOTPRINT: 3,511 SQ FT
 ENTRY STAIR: 477 SQ FT
 LEVEL 1 PATIO: 73 SQ FT
 LEVEL 2 PATIO: 316 SQ FT
 DRIVEWAY: 1,500 SQ FT
 TOTAL IMPERVIOUS AREA: 5,877 SQ FT
 PERCENTAGE LOT COVERAGE: 27.44 %

MECHANICAL, ELECTRICAL, AND PLUMBING NOTES

MECHANICAL, ELECTRICAL, AND PLUMBING DRAWINGS AND CALCULATIONS TO BE DEFERRED.

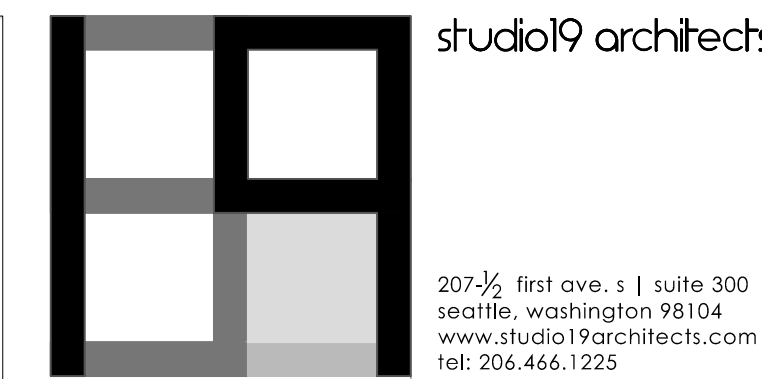

CONSULTANT: _____

PROFESSIONAL SEAL: _____

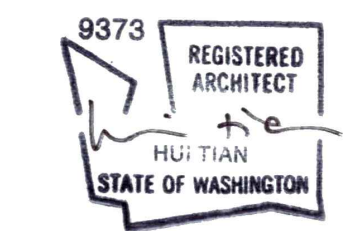

PROJECT: _____

a project for:

 PO BOX 1733 AUBURN, WA 98071
 Phone: (206) 724-1072

EAST MERCER RESIDENCE

4634 EAST MERCER WAY
 MERCER ISLAND, WA 98040

SHEET ISSUE: _____

| DATE | DESCRIPTION |
|------------|--------------------|
| 6/24/2015 | PERMIT SUBMITTAL |
| 8/29/2016 | PERMIT APPROVED |
| 6/05/2017 | REVISION TO PERMIT |
| 05/08/2018 | REVISION TO PERMIT |

MARK DATE DESCRIPTION

MUNICIPALITY REVIEW: _____

PROJECT # MERCER ISLAND 15 - 015

SHEET TITLE: _____

CODE SUMMARY

PROJECT NO.: 20140904

DATE ISSUED: 05/08/2018

SHEET NUMBER: _____

G0.02

Exhibit 5

WITHIN THE SE 1/4 PF THE SE 1/4 OF SECTION 18, TOWNSHIP 24 NORTH, RANGE 05 EAST, W.M., IN KING COUNTY, WASHINGTON

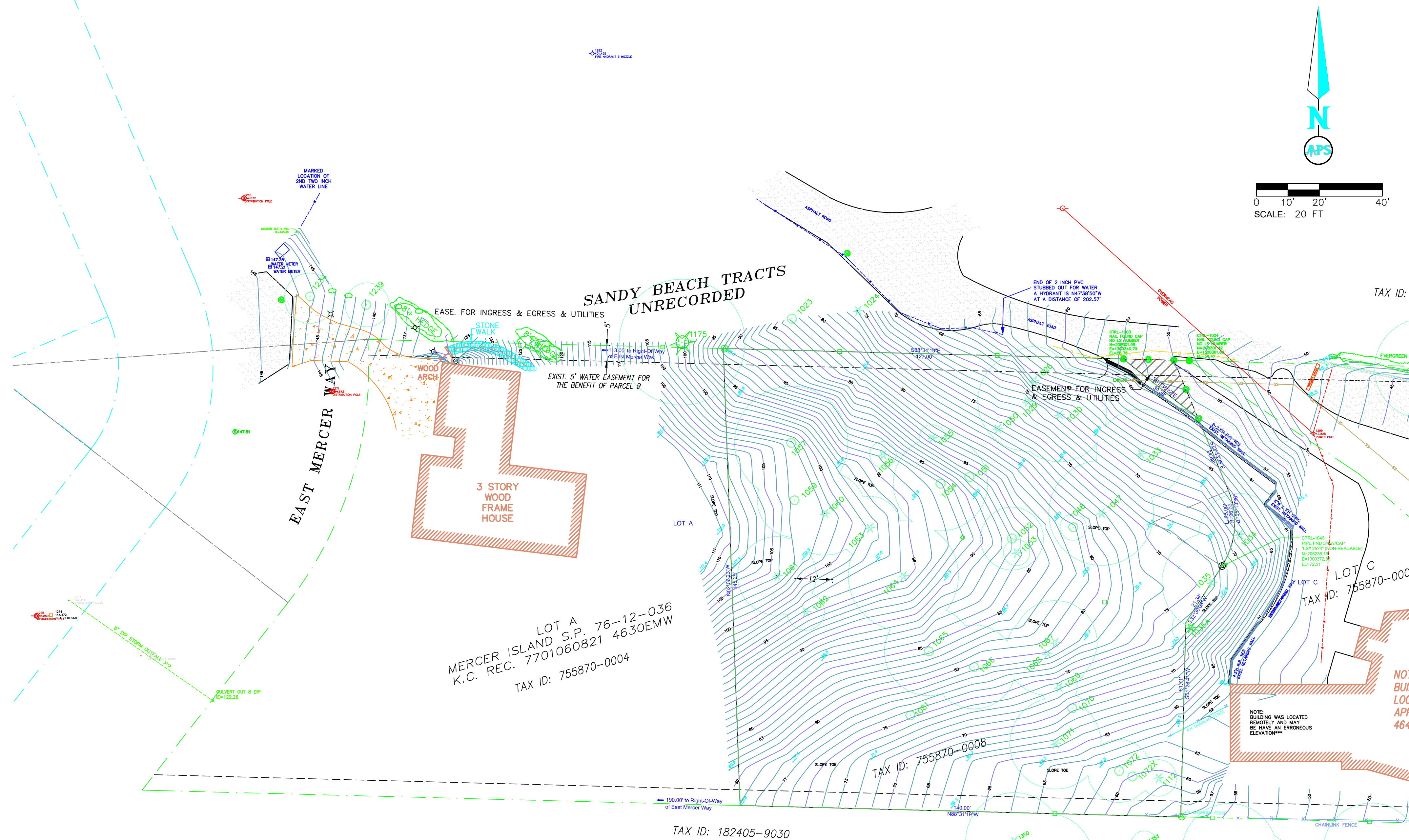

- GENERAL NOTES**
1. THE SOLE PURPOSE OF THIS SURVEY IS TO TOPOGRAPH AND ILLUSTRATE THE UTILITY, INGRESS/ EGRESS AND SEWER EASEMENT WITHIN THE PROPERTY, AS SHOWN HEREON.
 2. OUR CLIENT, BARCELO HOMES, HAS NOT FURNISHED APS SURVEY MAPPING WITH A TITLE REPORT OF THE BOUNDARIES. A COMBINATION OF RECORD OF SURVEYS AND PLATS WERE USED IN CONCERT WITH FOUND MONUMENTATION TO DETERMINE THE BOUNDARIES SHOWN HEREON. ACTUAL OWNERSHIP STATUS MAY VARY.
 3. THIS SURVEY WAS BASED ON A RTK VRS SURVEY USING TRIMBLE R8 UNITS IN COMBINATION WITH A CONVENTIONAL SURVEY USING TRIMBLE 5600 TOTAL STATIONS, LEICA 1" TO 5" TOTAL STATION. THIS NETWORK MEETS OR EXCEEDS THE ACCURACY STANDARDS SET BY WAC 332-130-090.
 4. ALL MONUMENTS WERE OCCUPIED OR OBSERVED DURING THE MONTH OF APRIL OF 2015.
 5. ALL MEASURING INSTRUMENTS AND EQUIPMENT USED FOR THIS SURVEY WERE MAINTAINED IN ADJUSTMENT ACCORDING TO MANUFACTURER'S SPECIFICATIONS.
 6. THIS SURVEY DOES NOT CONSTITUTE A SUBDIVISION OF LAND.
 7. THE LOCATION OF SUBSURFACE UTILITIES ARE BASED ON OBSERVED UTILITY PAINT MARKS ON THE SURFACE, AND SET THERE BY OTHERS.
 8. ALL COORDINATES AND BEARINGS ARE BASED ON OBSERVATIONS USING THE WASHINGTON STATE PREFERENCE NETWORK, THE WASHINGTON STATE PLANE COORDINATE SYSTEM, NORTH ZONE, EXPRESSED IN US SURVEY FEET.
 9. ALL VERTICAL ELEVATIONS ARE BASED ON NAVD88 DATUM FROM THE FOLLOWING DESCRIBED BENCHMARK.

SPECIAL SURVEY NOTE

THIS SURVEY WAS PREPARED FOR THE EXCLUSIVE USE OF BARCELO HOMES, AND DOES NOT EXTEND TO ANY UNNAMED PARTY WITHOUT EXPRESS RECERTIFICATION BY APS SURVEY MAPPING, LLC AND/OR THE PROFESSIONAL LAND SURVEYOR NAMED HEREON, NAMING SAID PARTY.

TYPICAL

OUTER CIRCLE = DRIPLINE
NUMBER ALONG SIDE = THE TREE DESCRIPTION ON THE CHART
THE TREE SYMBOL = A DECIDUOUS TREE

OUTER CIRCLE = DRIPLINE
NUMBER ALONG SIDE = THE TREE DESCRIPTION ON THE CHART
THE TREE SYMBOL = A EVERGREEN TREE

THE FOLLOWING HATCHING PATTERN AT THE NORTHWESTERLY CORNER OF LOT C REFERS TO AN EASEMENT ACROSS A PORTION OF LOT C CONTAINING AN INGRESS / EGRESS AND UTILITY EASEMENT FOR THE BENEFIT OF LOT B.

| REF | TYPE | DIA. (INCHES) | REF | TYPE | DIA. (INCHES) |
|-------|---------|----------------------------|------|--------|---------------|
| 1023 | MAPLE | 8 6 6 8 8 10 NORTH OF SITE | 1175 | CEDAR | 48 LOT A |
| 1024 | CEDAR | 14 NORTH OF SITE | 1234 | DECID. | 4 LOT A |
| 1026 | HEMLOCK | 26 | 1339 | DECID. | 4 LOT A |
| 1029 | FIR | 38 | 1308 | CEDAR | 36 LOT D |
| 1030 | FIR | 38 | 1329 | CEDAR | 22 LOT D |
| 1033 | FIR | 34 | 1326 | DECID. | 10 LOT D |
| 1034 | FIR | 31 | 1344 | CEDAR | 24 LOT D |
| 1035 | FIR | 38 | 1346 | CEDAR | 22 LOT D |
| 1035A | FIR | 4 FROM ARBORIST | 1347 | CEDAR | 18 LOT D |
| 1047 | FIR | 40 | 1348 | FIR | 18 LOT D |
| 1048 | CHERRY | 10 | 1349 | CEDAR | 26 LOT D |
| 1050 | FIR | 12 DEAD SNAG | | | |
| 1051 | MAPLE | 10 DEAD SNAG | | | |
| 1052 | MAPLE | 24 | | | |
| 1053 | CEDAR | 10 | | | |
| 1054 | MAPLE | 36 12 | | | |
| 1055 | HEMLOCK | 10 | | | |
| 1056 | FIR | 10 | | | |
| 1057 | MAPLE | 36 | | | |
| 1059 | MAPLE | 27 | | | |
| 1060 | FIR | 32 | | | |
| 1061 | FIR | 30 | | | |
| 1062 | HEMLOCK | 12 | | | |
| 1063 | FIR | 24 | | | |
| 1064 | FIR | 42 | | | |
| 1065 | MAPLE | 34 | | | |
| 1066 | MAPLE | 32 | | | |
| 1067 | FIR | 42 | | | |
| 1068 | CEDAR | 32 | | | |
| 1069 | CEDAR | 14 | | | |
| 1070 | MAPLE | 10 | | | |
| 1071 | CEDAR | 35 | | | |
| 1072 | MAPLE | 12 | | | |
| 1072X | MAPLE | 8 FROM ARBORIST | | | |
| 1081 | MAPLE | 16 DEAD SNAG | | | |
| 1112 | HEMLOCK | 14 | | | |

APS SURVEY & MAPPING
18274 S.E. 28TH STREET, SUITE A
BELLEVUE, WASHINGTON 98005
TEL: (425) 746-3200
FAX: (425) 746-3342

VOSB
Member Small Business
cve

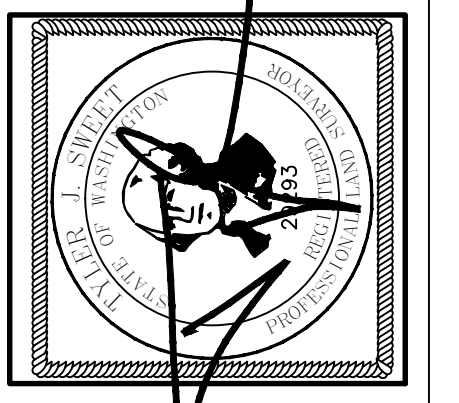

AS-BUILT SURVEY of
4634 EAST MERCER WAY
BARCELO HOMES

WASHINGTON
MERCER ISLAND
DATE: 5/27/15
APSSM PROJECT NO.: 1294002
ACAD DWG NAME: rev1294002-ARCH.DWG

| SURVEYED BY: | CHECKED BY: | APPROVED BY: | DATE | BY | REVISION | CK'D | APPR. |
|--------------|-------------|--------------|------|----|----------|------|-------|
| TJS | MAGC | | | | | | |

SHEET 1 OF 2

WITHIN THE SE 1/4 PF THE SE 1/4 OF SECTION 18, TOWNSHIP 24 NORTH, RANGE 05 EAST, W.M., IN KING COUNTY, WASHINGTON

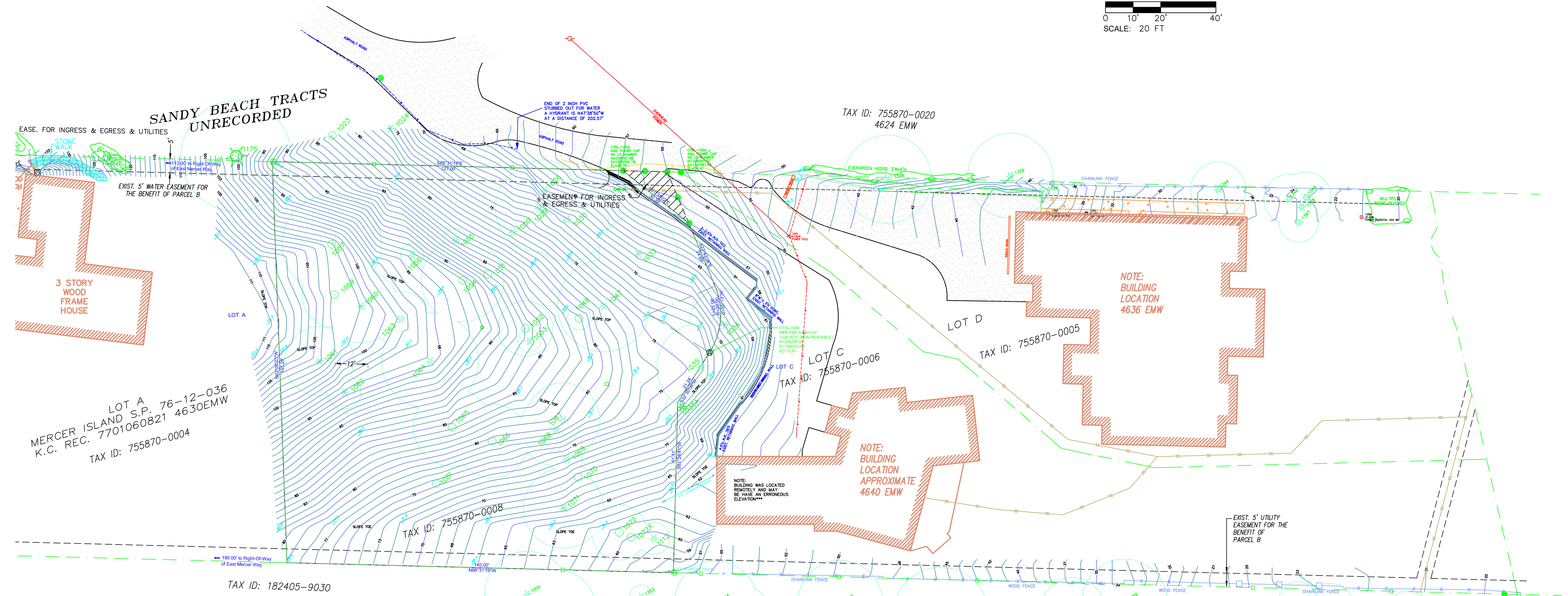
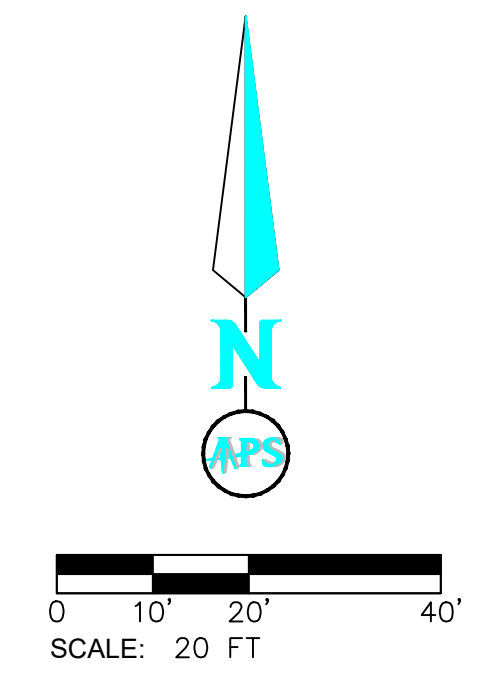

LOT A
MERCER ISLAND S.P. 76-12-036
K.C. REC. 7701060821 4630EMW
TAX ID: 755870-0004

TAX ID: 755870-0008

LOT C
TAX ID: 755870-0006

TAX ID: 755870-0020
4624 EMW

LOT D
TAX ID: 755870-0005

TAX ID: 182405-9030

SANDY BEACH TRACTS
UNRECORDED
4644 EMW

| REF | TYPE | DIA. (INCHES) |
|-------|---------|--------------------------|
| 1023 | MAPLE | 6 6 6 8 10 NORTH OF SITE |
| 1024 | CEDAR | 14 NORTH OF SITE |
| 1026 | HEMLOCK | 26 |
| 1029 | FIR | 38 |
| 1030 | FIR | 36 |
| 1033 | FIR | 34 |
| 1034 | FIR | 31 |
| 1035 | FIR | 38 |
| 1035A | FIR | 4 FROM ARBORIST |
| 1047 | FIR | 40 |
| 1048 | CHERRY | 10 |
| 1050 | FIR | 12 DEAD SNAG |
| 1051 | MAPLE | 10 DEAD SNAG |
| 1052 | MAPLE | 24 |
| 1053 | CEDAR | 10 |
| 1054 | MAPLE | 36 12 |
| 1055 | HEMLOCK | 10 |
| 1056 | FIR | 10 |
| 1057 | MAPLE | 36 |
| 1059 | MAPLE | 27 |
| 1060 | FIR | 32 |
| 1061 | FIR | 30 |
| 1062 | HEMLOCK | 12 |
| 1063 | FIR | 24 |
| 1064 | FIR | 42 |
| 1065 | MAPLE | 34 |
| 1066 | MAPLE | 32 |
| 1067 | FIR | 42 |
| 1068 | CEDAR | 32 |
| 1069 | CEDAR | 14 |
| 1070 | MAPLE | 10 |
| 1071 | CEDAR | 35 |
| 1072 | MAPLE | 12 |
| 1072X | MAPLE | 8 FROM ARBORIST |
| 1091 | MAPLE | 16 DEAD SNAG |
| 1112 | HEMLOCK | 14 |

| REF | TYPE | DIA. (INCHES) |
|------|--------|---------------|
| 1175 | CEDAR | 48 LOT A |
| 1234 | DECID. | 4 LOT A |
| 1359 | DECID. | 4 LOT A |
| 1308 | CEDAR | 38 LOT D |
| 1329 | CEDAR | 22 LOT D |
| 1326 | DECID. | 10 LOT D |
| 1344 | CEDAR | 24 LOT D |
| 1346 | CEDAR | 22 LOT D |
| 1347 | CEDAR | 18 LOT D |
| 1348 | CEDAR | 18 LOT D |
| 1349 | CEDAR | 26 LOT D |

ESTIMATED (COULD NOT GAIN ACCESS)

| | | |
|------|--------|-------------------|
| 1350 | CEDAR | 22 4644 E. MERCER |
| 1351 | CEDAR | 18 4644 E. MERCER |
| 1352 | DECID. | 8 4644 E. MERCER |
| 1353 | CEDAR | 8 4644 E. MERCER |
| 1354 | CEDAR | 22 4644 E. MERCER |
| 1355 | CEDAR | 16 4644 E. MERCER |
| 1356 | CEDAR | 22 4644 E. MERCER |
| 1357 | CEDAR | 26 4644 E. MERCER |
| 1358 | CEDAR | 12 4644 E. MERCER |
| 1359 | CEDAR | 22 4644 E. MERCER |
| 1360 | DECID. | 6 4644 E. MERCER |
| 1361 | DECID. | 10 4644 E. MERCER |
| 1362 | DECID. | 8 4644 E. MERCER |

TYPICAL

OUTER CIRCLE = DRIPLINE
NUMBER ALONG SIDE = THE TREE DESCRIPTION ON THE CHART
THE TREE SYMBOL = A DECIDUOUS TREE

OUTER CIRCLE = DRIPLINE
NUMBER ALONG SIDE = THE TREE DESCRIPTION ON THE CHART
THE TREE SYMBOL = A EVERGREEN TREE

THE FOLLOWING HATCHING PATTERN AT THE NORTHWESTERLY CORNER OF LOT C REFERS TO AN EASEMENT ACROSS A PORTION OF LOT C CONTAINING AN INGRESS / EGRESS AND UTILITY EASEMENT FOR THE BENEFIT OF LOT B.

APS
SURVEY & MAPPING
18274 S.E. 28TH STREET, SUITE A
BELLEVUE, WASHINGTON 98005
TEL: (425) 746-3200
FAX: (425) 746-3342

VOSB
Verified Small Business
cm

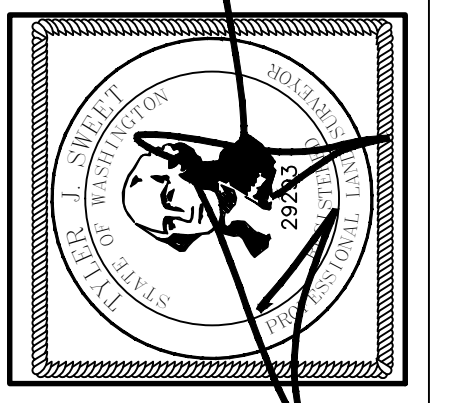

WASHINGTON
rev/294002-ARCH.DWG

AS-BUILT SURVEY of
4634 EAST MERCER WAY
BARCELO HOMES

MERCER ISLAND
DATE: 5/27/15
APSSM PROJECT NO.: 129-4002
ACAD DWG NAME:

| SURVEYED BY: | CHECKED BY: | APPROVED BY: | DATE | BY | REVISION | CK'D | APPR. |
|--------------|-------------|--------------|------|----|----------|------|-------|
| TJS | | | | | | | |
| MAGG | | | | | | | |

SHEET
2 OF 2

COVER SHEET

GENERAL NOTES

1. A PRE-CONSTRUCTION CONFERENCE SHALL BE HELD PRIOR TO THE START OF CONSTRUCTION. THE CONTRACTOR SHALL BE RESPONSIBLE FOR SECURING ALL NECESSARY PERMITS PRIOR TO CONSTRUCTION.
2. SPECIAL INSPECTIONS BY CITY INSPECTOR ARE REQUIRED DURING CONSTRUCTION. GENERAL CONTRACTOR TO COORDINATE.
3. ALL ROADWAY WORK AND MATERIAL SHALL BE IN ACCORDANCE WITH THE CURRENT APWA AND CITY OF MERCER ISLAND STANDARDS AND SPECIFICATIONS.
4. A COPY OF THE APPROVED CONSTRUCTION PLANS MUST BE ON THE JOB SITE WHENEVER CONSTRUCTION IS IN PROGRESS.
5. ALL TRENCH BACKFILL SHALL BE COMPACTED TO 95 PERCENT DENSITY IN ROADWAYS, ROADWAY SHOULDERS, ROADWAY PRISM AND DRIVEWAYS, AND 85 PERCENT DENSITY IN UNPAVED AREAS. ALL PIPE ZONE COMPACTON SHALL BE 95 PERCENT.
6. IT IS THE RESPONSIBILITY OF THE CONTRACTOR TO PROVIDE ADEQUATE TEMPORARY TRAFFIC CONTROL TO ENSURE TRAFFIC SAFETY DURING CONSTRUCTION ACTIVITIES. ALL TRAFFIC CONTROL DEVICES SHALL CONFORM TO THE "MANUAL ON UNIFORM TRAFFIC CONTROL DEVICES" (MUTCD).
7. MEASURES SHALL BE TAKEN BY THE DEVELOPER TO PROVIDE GROUND COVER IN AREAS WITHIN THE RIGHT-OF-WAY WHICH HAVE BEEN STRIPPED OF NATURAL VEGETATION OR HAVE A POTENTIAL FOR EROSION.
8. ANY EXISTING PUBLIC IMPROVEMENTS DAMAGED DURING CONSTRUCTION SHALL BE REPLACED PRIOR TO FINAL INSPECTION.
9. THE CONTRACTOR IS RESPONSIBLE FOR KEEPING ALL PUBLIC STREETS FREE FROM MUD AND DEBRIS AT ALL TIMES.
10. ALL EXISTING ON-SITE STRUCTURES AND ASSOCIATED UTILITIES TO BE DEMOLISHED, REMOVED, AND/OR ABANDONED PER APPLICABLE JURISDICTIONAL REQUIREMENTS.
11. DEFICIENCIES, WHETHER CAUSED BY CONTRACTOR OPERATIONS OR NOT CAUSED BY THE CONTRACTOR'S OPERATIONS, SHALL BE REPAIRED IMMEDIATELY.
12. THE CONTRACTOR SHALL MAINTAIN ROADS AND STREETS ADJACENT TO THE PROJECT LIMITS WHEN AFFECTED BY THE CONTRACTOR'S OPERATIONS. THE CONTRACTOR SHALL REMOVE OR REPAIR ANY CONDITION RESULTING FROM THE WORK THAT MIGHT IMPEDE TRAFFIC OR CREATE A HAZARD. PUBLIC ROADWAYS SHALL BE BROOMED CLEAN AT THE END OF EACH WORK DAY.
13. THE CONTRACTOR SHALL BE RESPONSIBLE FOR PROVIDING ADEQUATE SAFEGUARDS, SAFETY DEVICES, PROTECTIVE EQUIPMENT, AND ANY OTHER NEEDED ACTIONS TO PROTECT THE LIFE, HEALTH, AND SAFETY OF THE PUBLIC, AND TO PROTECT PROPERTY IN CONNECTION WITH THE PERFORMANCE OF THE WORK COVERED BY THE CONTRACT.
14. ROCKERIES AND/OR RETAINING WALLS TO BE CONSTRUCTED PER GEOTECHNICAL AND/OR STRUCTURAL ENGINEER'S PLANS & SPECIFICATIONS.

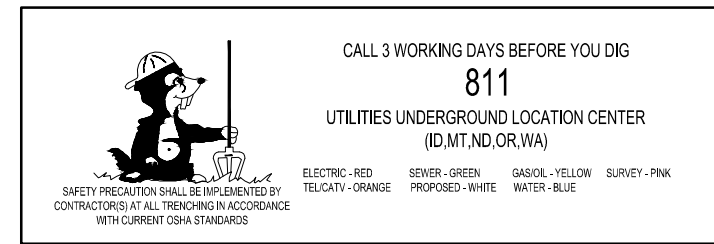
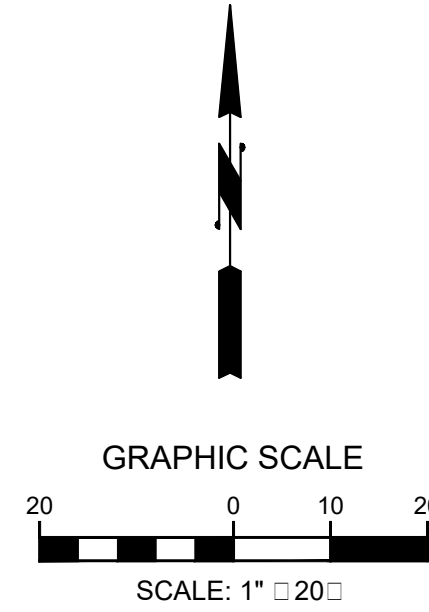

LEGEND

- FOUND PIPE
- SET HUB
- SET PK NAIL
- FOUND MANHOLE
- GAS METER
- GAS VALVE
- SOIL LOG/TEST PIT
- SANITARY SEWER MANHOLE
- CATCH BASIN
- WATER METER
- METLAND FLAG
- POWER METER
- AREA LIGHT
- POWER POLE
- SS SANITARY SEWER LINE
- SD STORM DRAIN LINE
- OHP OVERHEAD POWER LINE
- CONCRETE PAVING
- ASPHALT PAVING
- BUILDINGS
- GRAVEL SURFACE



VICINITY MAP
NOT TO SCALE

PROJECT DATA

PROPERTY ADDRESS: 4634 EAST MERCER WAY
MERCER ISLAND, WASHINGTON 98040
755870-0008
TAX LOT NUMBER: 21,350 SF (0.49 ACRES)
SITE AREA: R-15 = RESIDENTIAL 15
ZONING

LEGAL DESCRIPTION

SANDY BEACH TRS UNREC LOT B
CITY OF MERCER ISLAND SHORT
PLAT 76-12-036 REC #7701060821
SD SP DAF - LOTS 1-2 & 3;

PROJECT TEAM

OWNER/DEVELOPER: BARCELO HOMES
PO BOX 1733
AUBURN, WA 98071
CONTACT: BOGDAN MAKSIMCHUK
PHONE: (206) 724-1072

ARCHITECT: STUDIO 19 ARCHITECTS
207 1/2 1ST AVENUE SOUTH
SEATTLE, WASHINGTON 98104
CONTACT: ANDREW WISDOM
PHONE: (206) 466-1225

CIVIL ENGINEER: LITCHFIELD ENGINEERING
12840 81ST AVE NE
KIRKLAND, WA 98034
(425) 821-5038
CONTACT: KEITH LITCHFIELD, PE

GEOTECHNICAL ENGINEER: PANGE, INC
3213 EASTLAKE AVENUE E, STE. B
SEATTLE, WA 98102
CONTACT: MICHAEL H. XUE, PE
(206) 262-0374

SURVEYOR: APS SURVEYING AND MAPPING
13221 SE 26TH STREET, SUITE A
BELLEVUE, WASHINGTON 98005
CONTACT: TYLER SWEET, PLS
PHONE: (425) 746-3342

DATUM

NAVD88
BENCHMARK: POINT NAME: 4135:
1/4" BRASS PIN IN CONC.
(DOWN 1.0') INTX. E. MERCER WAY
& SE 68th ST,
ELEVATION: 158.465

SHEET INDEX

1. COVER SHEET
2. TESC PLAN
3. SITE IMPROVEMENT PLAN
4. CONSTRUCTION DETAILS
5. TEMPORARY EXCAVATION PLAN
6. STORM DRAIN OUTFALL PROFILE

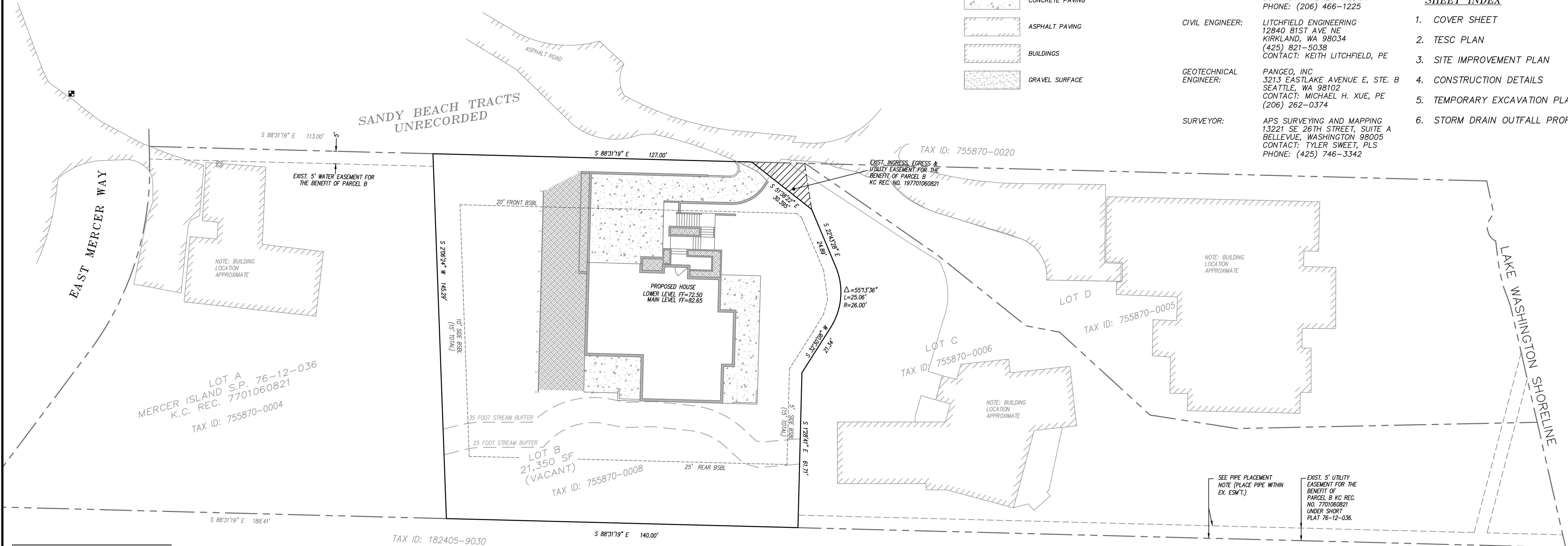

PROJECT CESCL
MICHAEL H. XUE, PE, CESCL
PANGE, INC.
(206) 262-0374 (O)
(206) 491-0081 (C)

APPROVED: _____
CITY OF MERCER ISLAND DEVELOPMENT SERVICES GROUP Date _____

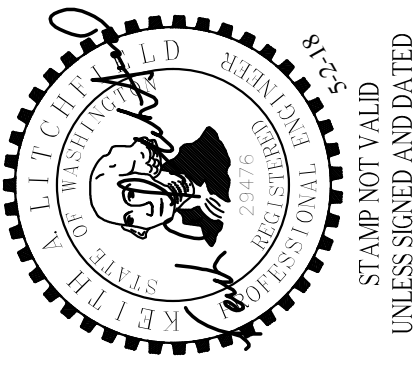

| DATE | DATE | DATE | DATE | DATE | DATE |
|----------|----------|----------|----------|----------|----------|
| 6-16-15 | 6-16-15 | 6-16-15 | 6-16-15 | 6-16-15 | 6-16-15 |
| 7-8-15 | 7-8-15 | 7-8-15 | 7-8-15 | 7-8-15 | 7-8-15 |
| 10-19-15 | 10-19-15 | 10-19-15 | 10-19-15 | 10-19-15 | 10-19-15 |
| 3-25-16 | 3-25-16 | 3-25-16 | 3-25-16 | 3-25-16 | 3-25-16 |
| 5-25-16 | 5-25-16 | 5-25-16 | 5-25-16 | 5-25-16 | 5-25-16 |
| 6-14-17 | 6-14-17 | 6-14-17 | 6-14-17 | 6-14-17 | 6-14-17 |

LITCHFIELD ENGINEERING
12840 81ST AVENUE NE
Kirkland, WA 98034
Tel: (425) 821-5038 Fax: (425) 821-5789

COVER SHEET
BARCELO HOMES SFR,
4634 EAST MERCER WAY
BOGDAN MAKSIMCHUK
BOB 1798071
AUBURN, WA 98071

CONSTRUCTION SEQUENCE:

1. ATTEND PRE-CONSTRUCTION MEETING
2. FLAG CLEARING LIMITS
3. INSTALL ORANGE TREE BARRIER FENCING
4. INSPECTION BY CITY OF MERCER ISLAND INSPECTOR
5. EROSION CONTROL DEVICES AND RESOURCES TO COVER ALL SOIL, IN CASE OF EROSION RISK, ARE TO BE ON THE SITE AT ALL TIMES
6. INSTALL 2 ROWS OF SILT FENCING ALONG THE EDGE OF CLEARING LIMITS
7. INSTALL FILTER SOCKS ON ALL DOWN GRADIENT STORM DRAIN INLETS.
8. CONSTRUCT TEMPORARY GRAVEL CONSTRUCTION ENTRANCE
9. CLEAR AND GRUB WITHIN CLEARING LIMITS
10. PERFORM SITE GRADING
11. KEEP PRIVATE ACCESS DRIVE FREE OF DIRT AND DEBRIS AT ALL TIMES.
12. CONSTRUCT BUILDING FOUNDATIONS, FOOTING DRAINS, AND WALL BACK DRAINS
13. CONSTRUCT DRAINAGE TIGHT LINE TO THE LAKE (PROPERTY OWNER OF LOT C TO BE PRESENT)
14. BACKFILL FOUNDATIONS AND RETAINING WALLS WITH DRAIN ROCK OR OTHER POROUS MATERIAL APPROVED BY PROJECT GEOTECH.
15. FINISH GRADE
16. APPLY PERMANENT VEGETATION AND MULCH ALL DISTURBED AREAS
17. CLEAN-UP THE SITE. TEMPORARY EROSION CONTROL DEVICES MAY BE REMOVED WITHIN 30 DAYS AFTER FINAL SITE STABILIZATION OR AFTER THEY ARE NO LONGER NECESSARY. PROJECT CESCL TO INSPECT SITE AND APPROVE REMOVAL OF TEMPORARY EROSION CONTROL MEASURES.

EROSION/SEDIMENT CONTROL NOTES

1. PRIOR TO BEGINNING EARTH DISTURBING ACTIVITIES, INCLUDING CLEARING AND GRADING, ALL CLEARING LIMITS, EASEMENTS, SETBACKS, TREES AND DRAINAGE COURSES SHALL BE CLEARLY DEFINED AND MARKED IN THE FIELD TO PREVENT DAMAGE AND OFFSITE IMPACTS.
2. CONSTRUCTION VEHICLE ACCESS AND EXIT SHALL BE LIMITED TO ONE ROUTE IF POSSIBLE. ACCESS POINTS SHALL BE STABILIZED WITH QUARRY SPALLS OR CRUSHED ROCK TO MINIMIZE THE TRACKING OF SEDIMENTS ONTO PUBLIC STREETS. WHEEL WASH OR TIRE BATHS SHALL BE LOCATED ON-SITE. IF SEDIMENT IS TRANSPORTED ONTO A ROAD SURFACE, THE PAVEMENT SHALL BE CLEANED THOROUGHLY AT THE END OF EACH DAY. SEDIMENT SHALL BE REMOVED FROM THE PAVEMENT BY SHOVELING OR SWEEPING AND BE TRANSPORTED TO A CONTROLLED SEDIMENT DISPOSAL AREA. STREET WASHING WILL ONLY BE ALLOWED AFTER SEDIMENT IS REMOVED IN THIS MANNER. PAVEMENT WASHING SHALL NOT OCCUR UNTIL ALL STORM DRAIN INLETS, LOCATED DOWNSTREAM OF THE WASHING AREA, HAVE BEEN PROTECTED BY PLACEMENT OF A FILTER CLOTH UNDER THE INLET GRATE.
3. PROPERTIES AND WATERWAYS DOWNSTREAM FROM THE DEVELOPMENT SITE SHALL BE PROTECTED FROM EROSION DUE TO INCREASES IN THE VOLUME, VELOCITY, AND PEAK FLOW RATE OF STORMWATER RUNOFF FROM THE PROJECT SITE.
4. PRIOR TO LEAVING THE SITE, STORMWATER RUNOFF SHALL PASS THROUGH APPROVED SEDIMENT BARRIERS OR FILTERS, DIKES, OR ANY OTHER APPROVED FACILITY INTENDED TO TRAP SEDIMENT. THESE SEDIMENT CONTROLLING MEASURES SHALL BE CONSTRUCTED AS THE FIRST STEP IN GRADING. THESE FACILITIES SHALL BE FUNCTIONAL BEFORE ANY OTHER LAND DISTURBING ACTIVITY TAKES PLACE. EARTHEN STRUCTURES SUCH AS DAMS, DIKES, AND DIVERSIONS SHALL BE SEEDED AND MULCHED ACCORDING TO THE TIMING INDICATED UNDER ITEM 5.
5. ALL EXPOSED AND UNWORKED SOILS SHALL BE STABILIZED BY THE PLACEMENT OF SOD OR OTHER VEGETATION, PLASTIC COVERING, MULCHING, APPLICATION OF BASE ROCK WITHIN AREAS TO BE PAVED, OR SOME OTHER APPROVED MEANS, TO PROTECT THE SOIL FROM THE EROSIIVE FORCES OF RAINDROP IMPACT AND FLOWING WATER. FROM OCTOBER 1 THROUGH APRIL 30, NO SOILS SHALL REMAIN EXPOSED AND UNWORKED FOR MORE THAN 2 DAYS. FROM MAY 1 THROUGH SEPTEMBER 30, NO SOIL SHALL REMAIN EXPOSED AND UNWORKED FOR MORE THAN 7 DAYS. THIS CONDITION APPLIES TO ALL SOILS ON SITE, WHETHER AT FINAL GRADE OR NOT. THE SOIL STABILIZATION MEASURES SELECTED SHOULD BE APPROPRIATE FOR THE TIME OF YEAR, SITE CONDITIONS, ESTIMATED DURATION OF USE, AND THE POTENTIAL WATER QUALITY IMPACTS THAT THE STABILIZATION MEASURES MAY HAVE ON THE DOWNSTREAM WATERS. SOIL STOCKPILES SHALL BE STABILIZED AND PROTECTED WITH SEDIMENT TRAPPING MEASURES.
6. CUT AND FILL SLOPES SHALL BE DESIGNED AND CONSTRUCTED IN A MANNER THAT WILL MINIMIZE EROSION. CONSIDER SOIL TYPE AND ITS POTENTIAL FOR EROSION. REDUCE SLOPE RUNOFF VELOCITIES BY (1) REDUCING THE LENGTH OF CONTINUOUS SLOPES BY USING TERRACING AND DIVERSIONS, (2) REDUCING THE GRADE OF THE SLOPE, AND (3) ROUGHEN SLOPE SURFACE. CONTAIN DOWNSLOPE COLLECTED WATER IN PIPES OR PROTECTED CHANNELS.
7. ALL STORM DRAIN INLETS MADE OPERABLE DURING CONSTRUCTION SHALL BE PROTECTED SO THAT STORMWATER RUNOFF SHALL NOT ENTER THE CONVEYANCE SYSTEM WITHOUT FIRST BEING FILTERED OR TREATED TO REMOVE SEDIMENTS.
8. ALL TEMPORARY ON-SITE CONVEYANCE CHANNELS SHALL BE DESIGNED, CONSTRUCTED AND STABILIZED TO PREVENT EROSION. STABILIZATION, INCLUDING ARMORING MATERIAL, ADEQUATE TO PREVENT EROSION AT ALL DISCHARGE POINTS, ADJACENT STREAM BANKS, SLOPES AND DOWNSTREAM REACHES, SHALL BE PROVIDED.
9. ALL POLLUTANTS, INCLUDING WASTE MATERIALS AND DEMOLITION DEBRIS, THAT OCCUR ON-SITE DURING CONSTRUCTION SHALL BE HANDLED AND DISPOSED OF IN A MANNER THAT DOES NOT CAUSE CONTAMINATION OF STORMWATER. MAINTENANCE AND REPAIR OF HEAVY EQUIPMENT AND VEHICLES INVOLVING OIL CHANGES, HYDRAULIC SYSTEM DRAIN DOWN, SOLVENT AND DE-GREASING CLEANING OPERATIONS AND OTHER ACTIVITIES WHICH MAY RESULT IN DISCHARGE OR SPILLAGE OF POLLUTANTS TO THE GROUND OR INTO STORMWATER RUNOFF, MUST BE CONDUCTED UNDER COVER AND ON IMPERVIOUS SURFACES. THESE SURFACES SHALL BE CLEANED IMMEDIATELY FOLLOWING ANY DISCHARGE OR SPILLAGE INCIDENT. WHEEL WASH, OR TIRE BATH WASTEWATER, SHALL NOT BE DISCHARGED TO THE STORM DRAIN, OR ON-SITE STORMWATER TREATMENT SYSTEM.
10. ALL TEMPORARY AND PERMANENT EROSION AND SEDIMENT CONTROL FACILITIES SHALL BE MAINTAINED AND REPAIRED AS NEEDED TO ASSURE CONTINUED PERFORMANCE OF THEIR INTENDED FUNCTION.

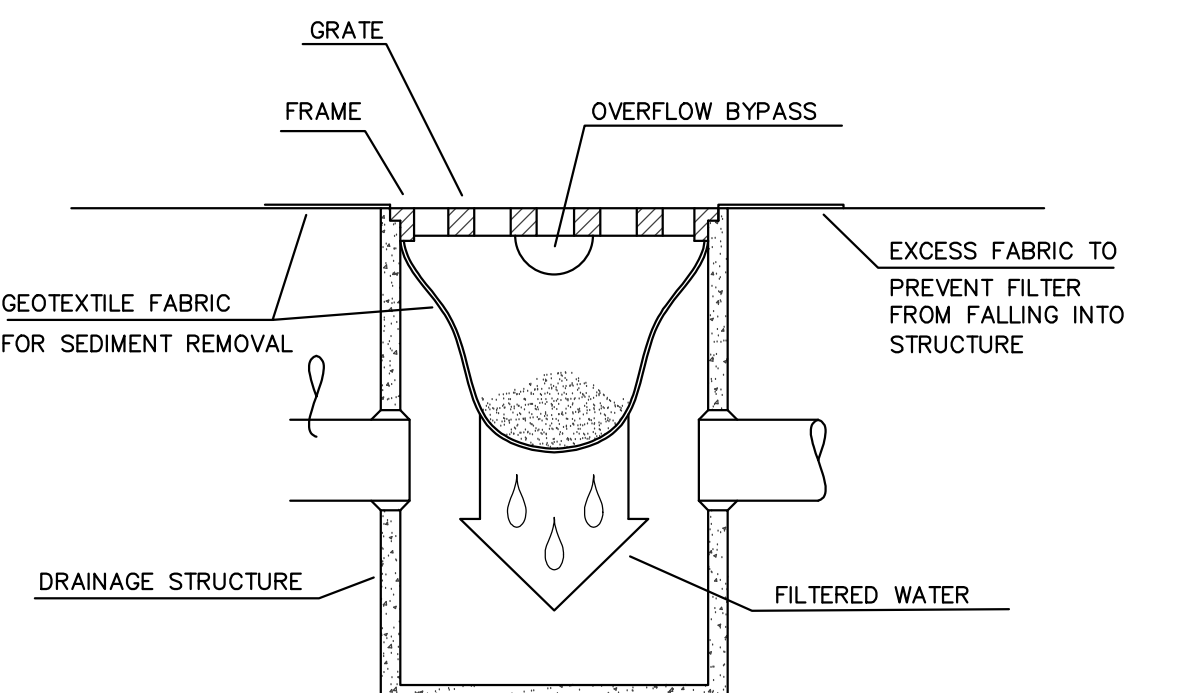
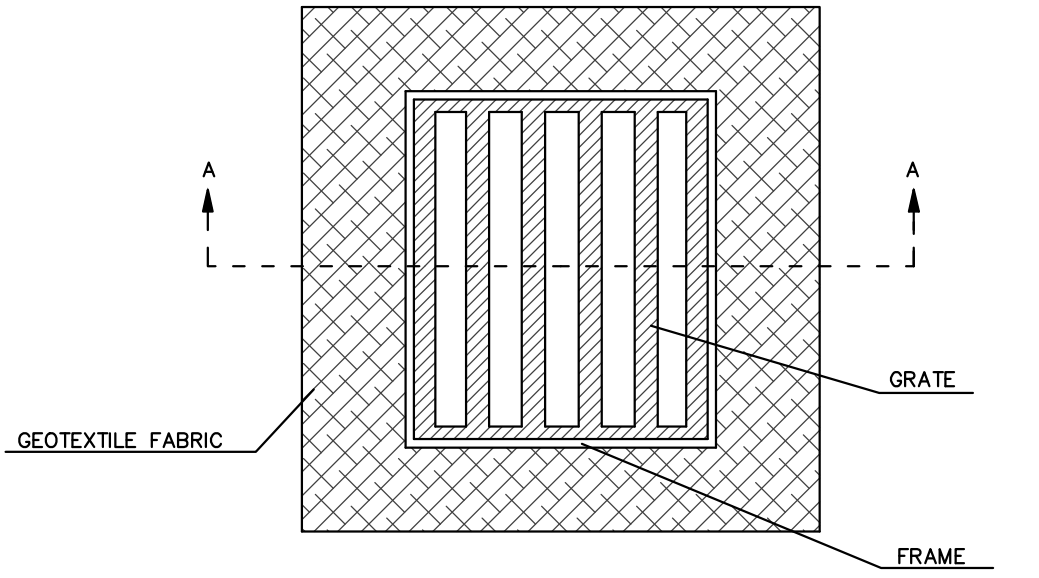
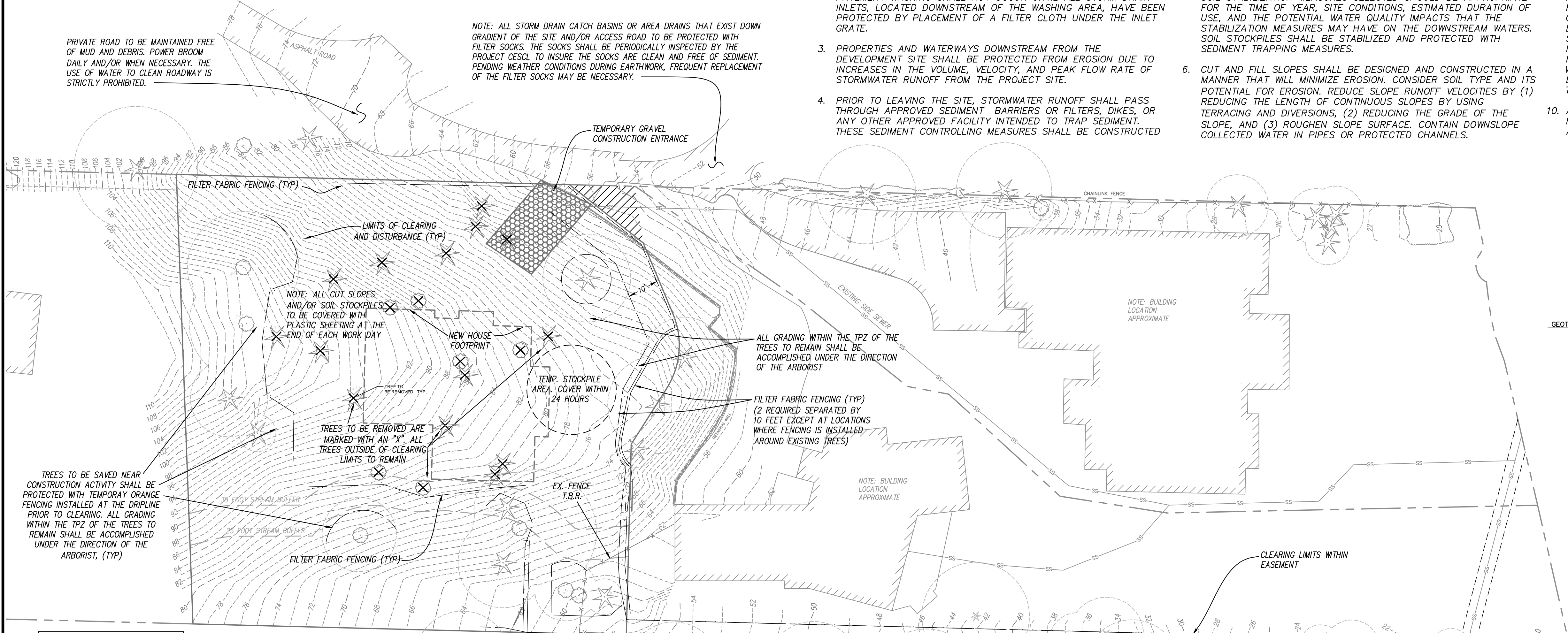
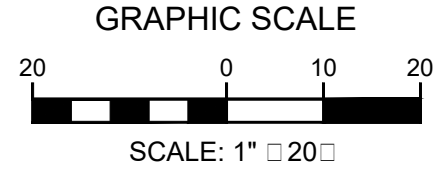

EROSION CONTROL LEAD:
MICHAEL XUE, P.E.
PAN GEO, INC.
PHONE: (206) 262-0374

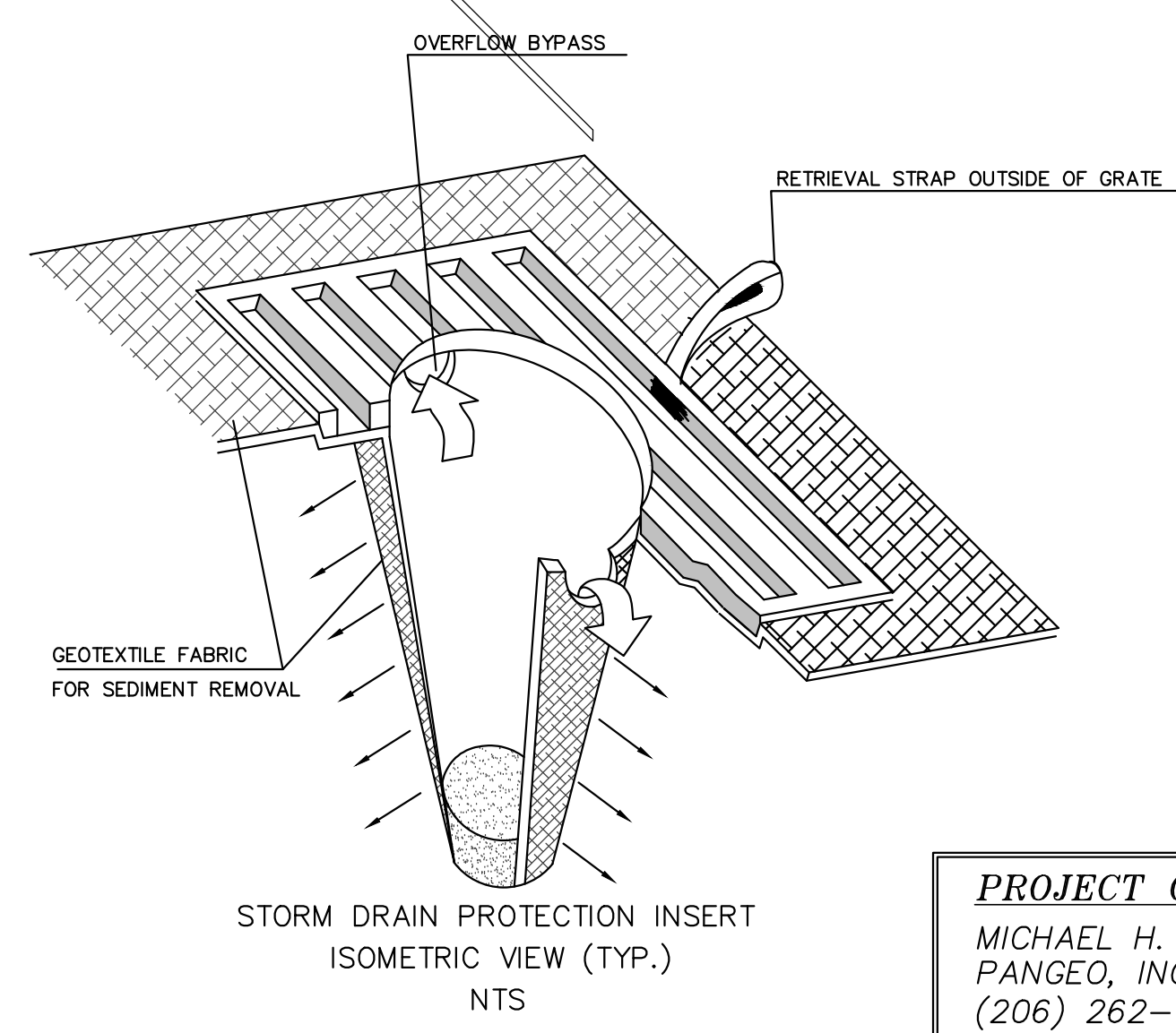
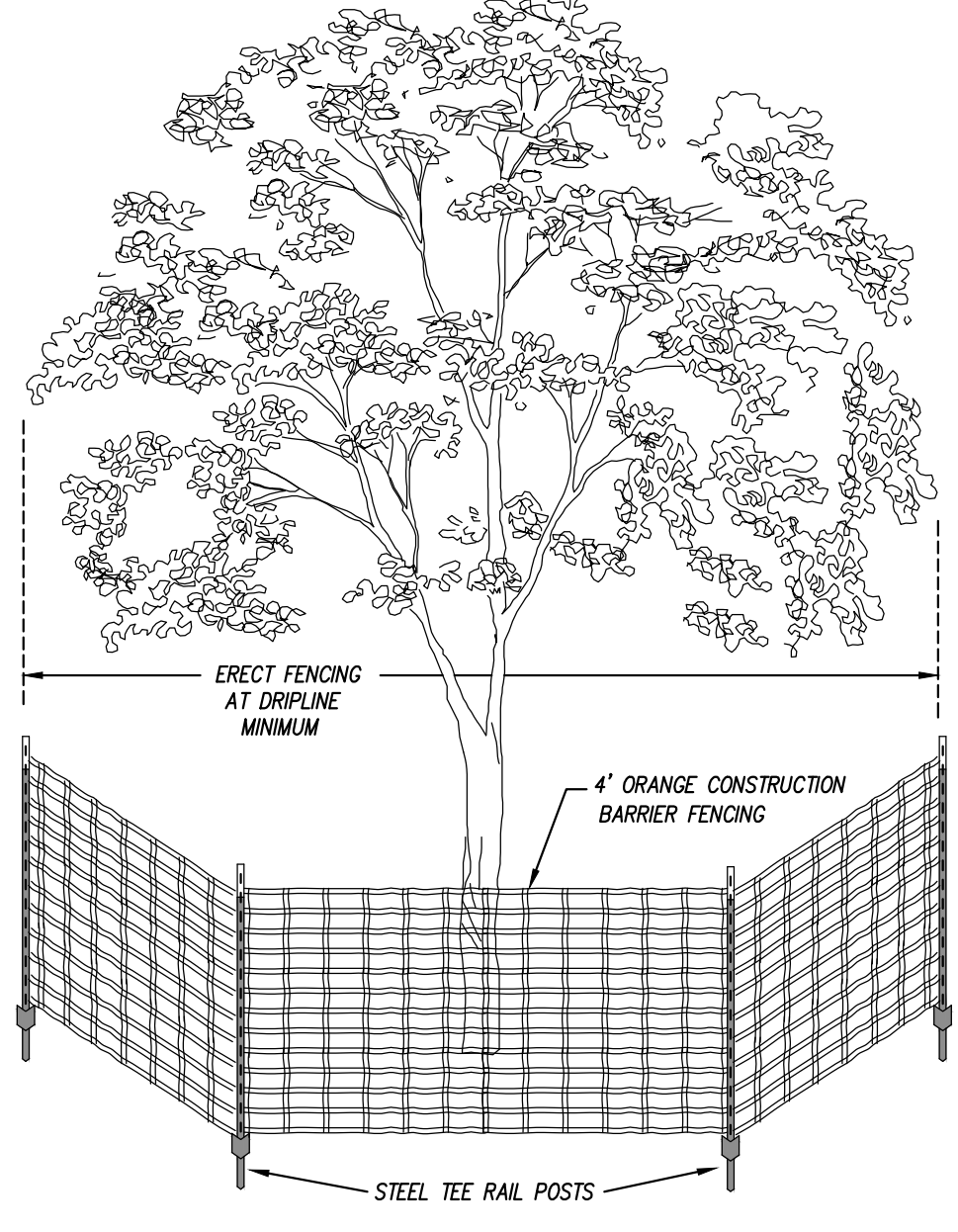
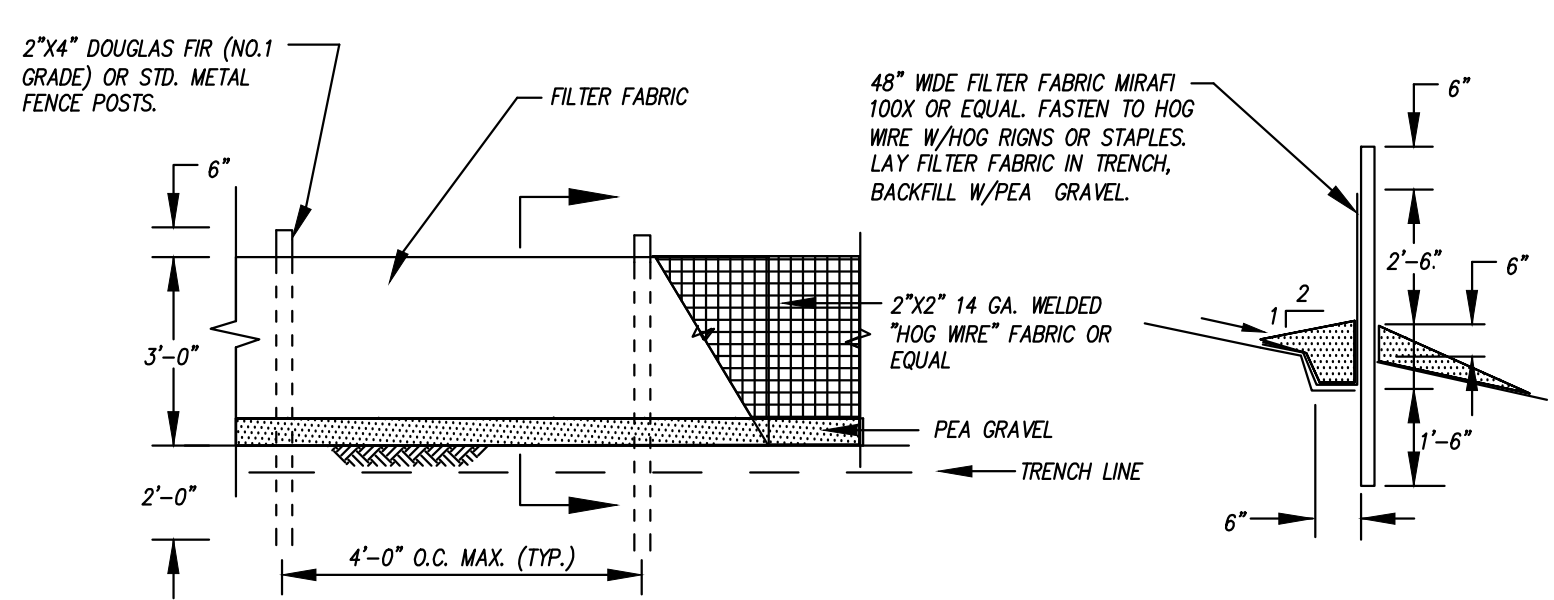
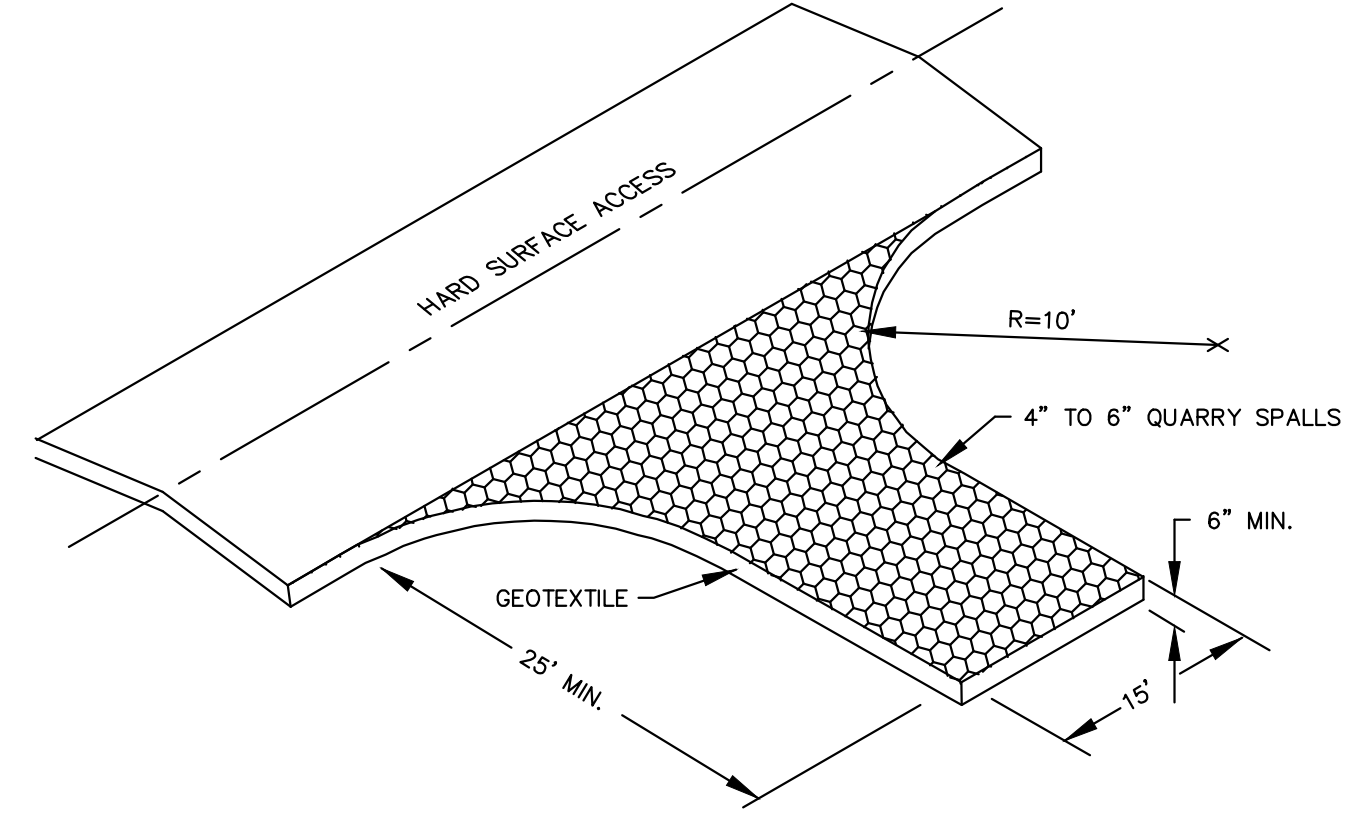
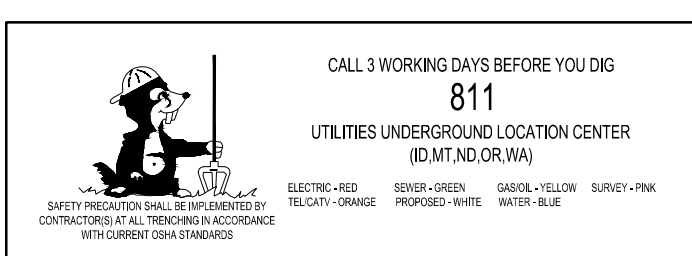

PROJECT CESCL
MICHAEL H. XUE, PE, CESCL
PANGELO, INC.
(206) 262-0374 (O)
(206) 491-0081 (C)

APPROVED: CITY OF MERCER ISLAND DEVELOPMENT SERVICES GROUP Date

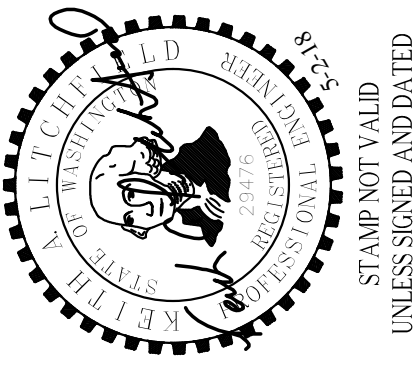

| DATE | NOTES |
|---|------------------------------|
| 6-16-15 <td>SUBMITTED TO CLIENT</td> | SUBMITTED TO CLIENT |
| 10-1-15 <td>REVISED PER CITY COMMENTS</td> | REVISED PER CITY COMMENTS |
| 10-19-15 <td>REVISED PER CITY COMMENTS</td> | REVISED PER CITY COMMENTS |
| 3-25-16 <td>ADD EXCAVATION PLAN: SHEET 5</td> | ADD EXCAVATION PLAN: SHEET 5 |
| 5-25-16 <td>PER CITY COMMENTS</td> | PER CITY COMMENTS |
| 6-14-17 <td>UPDATED PER STREAM BUFFER</td> | UPDATED PER STREAM BUFFER |

LITCHFIELD ENGINEERING
12840 81ST AVENUE NE
Kirkland, WA 98034
Tel: (425) 821-2088 Fax: (425) 821-5789
Copyright © 2000 Litchfield Engineering, Inc. All rights reserved.

T.E.S.C. PLAN
BARCELLO HOMES SFR.
4634 EAST MERCER WAY
BOGDAN MAKSYMCHUK
BOB LITVIN
AUBURN, WA 98007

SITE IMPROVEMENT NOTES

1. PROOF OF LIABILITY INSURANCE SHALL BE SUBMITTED TO THE CITY PRIOR TO THE PRE-CONSTRUCTION MEETING.
2. THESE PLANS ARE APPROVED FOR GRADING, DRAINAGE, AND UTILITY IMPROVEMENTS ONLY. PLANS FOR STRUCTURES REQUIRE A SEPARATE REVIEW AND APPROVAL.
3. RETAINING WALLS GREATER THAN FOUR (4) FEET IN HEIGHT REQUIRE A SEPARATE BUILDING PERMIT.
4. FILL MATERIAL PLACED UNDER BUILDING FOUNDATIONS OR PAVEMENT SHALL BE CRUSHED BASE ROCK OR COMPACTED STRUCTURAL FILL IN ACCORDANCE WITH CITY AND WSDOT STANDARD SPECIFICATIONS.
5. ALL DRAINAGE STRUCTURES, SUCH AS CATCH BASINS AND MANHOLES, NOT LOCATED WITHIN A TRAVELED ROADWAY OR SIDEWALK, SHALL HAVE SOLID LOCKING LIDS.
6. THIS PLAN DOES NOT SHOW THE LOCATION OF ALL EXISTING UTILITIES. IT IS THE RESPONSIBILITY OF THE CONTRACTOR TO LOCATE ALL EXISTING UTILITIES PRIOR TO EXCAVATION.
7. THE CONTRACTOR SHALL EXPOSE ALL EXISTING PIPING THAT WILL BE CONNECTED TO WITH NEW PIPING. DEPTH, LOCATION, AND CONDITION SHALL BE RELAYED TO THE ENGINEER IF CONDITIONS VARY SIGNIFICANTLY FROM WHAT IS DETAILED OR ANTICIPATED.
8. ALL WORK SHALL BE PERFORMED IN STRICT ACCORDANCE TO DETAILS AND SPECIFICATIONS OF CITY STANDARDS. ALL CONSTRUCTION DEBRIS GENERATED DURING CONSTRUCTION TO BE REMOVED & DISPOSED OF AT AN APPROVED LOCATION OFF-SITE.
9. ALL CUT MATERIAL GENERATED DURING THE PROJECT THAT IS NOT ACCEPTABLE FOR USE AS COMPACTED FILL MATERIAL AT ANOTHER LOCATION ON-SITE MUST BE HAULED TO AN APPROVED LOCATION OFF-SITE.

DRAINAGE GENERAL NOTES

1. A PRE-CONSTRUCTION CONFERENCE SHALL BE HELD PRIOR TO THE START OF CONSTRUCTION. THE CONTRACTOR SHALL BE RESPONSIBLE FOR SECURING ALL NECESSARY PERMITS PRIOR TO CONSTRUCTION.
2. BEFORE ANY CONSTRUCTION MAY OCCUR, THE CONTRACTOR SHALL HAVE PLANS WHICH HAVE BEEN SIGNED AND APPROVED BY THE CITY OF MERCER ISLAND PUBLIC WORKS DEPARTMENT, OBTAINED ALL CITY, COUNTY, STATE, FEDERAL AND OTHER REQUIRED PERMITS, AND HAVE POSTED ALL REQUIRED BONDS.
3. ALL STORM DRAINAGE IMPROVEMENTS SHALL BE DESIGNED AND CONSTRUCTED IN ACCORDANCE WITH THE LATEST EDITION OF THE CITY OF MERCER ISLAND PUBLIC WORKS PRE-APPROVED PLANS AND POLICIES AND THE STANDARD SPECIFICATIONS FOR ROAD, BRIDGE AND MUNICIPAL CONSTRUCTION, PREPARED BY WSDOT AND THE AMERICAN PUBLIC WORKS ASSOCIATION (APWA).
4. ANY DEVIATION FROM THE APPROVED PLANS WILL REQUIRE WRITTEN APPROVAL. ALL CHANGES SHALL BE SUBMITTED TO THE CITY.
5. A COPY OF THE APPROVED STORM WATER PLANS MUST BE ON THE JOB SITE WHENEVER CONSTRUCTION IS IN PROGRESS.
6. ALL DISTURBED AREAS SHALL BE SEEDED AND MULCHED OR SIMILARLY STABILIZED TO THE SATISFACTION OF THE CITY OF MERCER ISLAND DEPARTMENT OF PUBLIC WORKS FOR THE PREVENTION OF ON-SITE EROSION AFTER THE COMPLETION OF CONSTRUCTION.
7. MINIMUM COVER OVER STORM DRAINAGE PIPES IN ROW OR VEHICULAR PATH SHALL BE 18 INCHES, UNLESS OTHER DESIGN IS APPROVED.
8. CONSTRUCTION OF DEWATERING (GROUNDWATER) SYSTEMS SHALL BE IN ACCORDANCE WITH THE APWA STANDARD SPECIFICATIONS.
9. ALL TRENCH BACKFILL SHALL BE COMPACTED TO 95 PERCENT DENSITY IN ROADWAYS, ROADWAY SHOULDERS, ROADWAY PRISM AND DRIVEWAYS, AND 85 PERCENT DENSITY IN UNPAVED AREAS. ALL PIPE ZONE COMPACTION SHALL BE 95 PERCENT.

10. THE CONTRACTOR SHALL BE RESPONSIBLE FOR PROVIDING ADEQUATE SAFEGUARDS, SAFETY DEVICES, PROTECTIVE EQUIPMENT, CONFINED SPACE PROTECTION, FLAGGERS, AND ANY OTHER NEEDED ACTIONS TO PROTECT THE LIFE, HEALTH, AND SAFETY OF THE PUBLIC, AND TO PROTECT PROPERTY IN CONNECTION WITH THE PERFORMANCE OF WORK COVERED BY THE CONTRACT.
11. APPROXIMATE LOCATIONS OF EXISTING UTILITIES HAVE BEEN OBTAINED FROM AVAILABLE RECORDS AND ARE SHOWN FOR CONVENIENCE. THE CONTRACTOR SHALL BE RESPONSIBLE FOR VERIFICATION OF EXISTING UTILITY LOCATIONS WHETHER OR NOT THESE UTILITIES ARE SHOWN ON THE PLANS. THE CONTRACTOR SHALL EXERCISE ALL CARE TO AVOID DAMAGE TO ANY UTILITY. IF CONFLICTS WITH EXISTING UTILITIES ARISE DURING CONSTRUCTION, THE CONTRACTOR SHALL NOTIFY THE CITY CONSTRUCTION INSPECTOR AND ANY CHANGES REQUIRED SHALL BE APPROVED BY THE DEVELOPMENT ENGINEER PRIOR TO COMMENCEMENT OF RELATED CONSTRUCTION ON THE PROJECT.
12. THE UNDERGROUND UTILITY LOCATION SERVICE SHALL BE CONTACTED FOR FIELD LOCATION OF EXISTING UTILITIES PRIOR TO ANY CONSTRUCTION. THE OWNER OR HIS REPRESENTATIVE SHALL BE CONTACTED IF A UTILITY CONFLICT EXISTS. FOR UTILITY LOCATION IN KING COUNTY, CALL 811. THE CONTRACTOR IS RESPONSIBLE TO ENSURE THAT UTILITY LOCATES ARE MAINTAINED THROUGHOUT THE LIFE OF THE PROJECT.
13. OPEN CUT ROAD CROSSINGS FOR UTILITY TRENCHES ON EXISTING TRAVELED ROADWAY SHALL BE BACKFILLED ONLY WITH 5/8" MINUS CRUSHED ROCK AND MECHANICALLY COMPACTED (UNLESS OTHERWISE APPROVED BY THE CITY). CUTS INTO THE EXISTING ASPHALT SHALL BE NEAT LINE CUT WITH SAW OR JACKHAMMER IN A CONTINUOUS LINE. A TEMPORARY COLD MIX PATCH MUST BE PLACED IMMEDIATELY AFTER BACKFILL AND COMPACTION. A PERMANENT HOT MIX PATCH SHALL BE PLACED WITHIN 30 DAYS AND SHALL BE A MINIMUM OF 1" THICKER THAN THE ORIGINAL ASPHALT WITH A MINIMUM THICKNESS OF 2".
14. ALL DAMAGES INCURRED TO PUBLIC AND/OR PRIVATE PROPERTY BY THE CONTRACTOR DURING THE COURSE OF CONSTRUCTION SHALL BE PROMPTLY REPAIRED TO THE SATISFACTION OF THE CITY CONSTRUCTION INSPECTOR BEFORE PROJECT APPROVAL AND/OR THE RELEASE OF THE PROJECT'S PERFORMANCE BOND.
15. GROUT ALL SEAMS AND OPENINGS IN ALL INLETS, CATCH BASINS, AND MANHOLES.

① PUMP SYSTEM CALL-OUT

ORENCO 30" PUMP BASIN & COVER W/DUPLEX SUBMERSIBLE PUMPS. PUMPS TO BE ALTERNATING AND FUNCTION AS A LEAD/LAG SYSTEM RIM = 61.00
IE 6" PVC @ 55.00 (ALL PIPES)
BASE = 51.00
(PER PUMP SYSTEM DETAIL)

② BACK-UP GENERATOR NOTES

1. ELECTRICAL CONTRACTOR TO PROVIDE GENERATOR AND TRANSFER SWITCH FOR BATTERY BACK-UP & AUTO START FOR SERVICE TO PUMPS DURING UTILITY OUTAGE.
2. DUPLEX PUMP CONTROL PANEL & TRANSFER SWITCH TO BE LOCATED IN GARAGE.

ARCHITECTURAL, STRUCTURAL & GEOTECHNICAL NOTES

1. THESE PLANS ARE APPROVED FOR STANDARD ROAD AND DRAINAGE IMPROVEMENTS ONLY. PLANS FOR STRUCTURES SUCH AS RETAINING WALLS REQUIRE A SEPARATE REVIEW AND APPROVAL PRIOR TO CONSTRUCTION.
2. SPECIAL INSPECTIONS FOR GEOTECHNICAL AND/OR STRUCTURAL ASPECTS OF THE PROJECT MAY BE REQUIRED DURING VARIOUS STAGES OF THE PROJECT. CONTRACTOR TO BE RESPONSIBLE FOR COORDINATION AND OBTAINING INSPECTIONS WHEN AND WHERE NECESSARY.
3. SEE ARCHITECTURAL PLANS FOR BUILDING SECTIONS AND ALL LOCAL/DIMENSIONAL ASPECTS OF BUILDINGS.
4. SEE ARCHITECTURAL AND STRUCTURAL PLANS FOR ALL BUILDING AND RETAINING WALL DETAILS.
5. COORDINATE ALL SITE CIVIL CONSTRUCTION WITH ARCHITECTURAL, STRUCTURAL, MECHANICAL/PLUMBING AND LANDSCAPE PLANS AND IN ACCORDANCE WITH GEOTECHNICAL RECOMMENDATIONS.
6. PRIOR TO CONSTRUCTION THE EARTHWORK/GENERAL CONTRACTOR TO BE COMPLETELY FAMILIAR WITH THE GEOTECHNICAL REPORT AND RECOMMENDATIONS. PLEASE REVIEW PANGEO, INC.'S REPORT DATED MARCH 31, 2014 AND CONTACT MICHAEL XUE, PE ON ANY QUESTIONS OR CONCERNS REGARDING HIS RECOMMENDATIONS.

GRADING NOTES:

1. ALL CUT MATERIAL GENERATED DURING THE PROJECT THAT IS NOT ACCEPTABLE FOR USE AS COMPACTED FILL MATERIAL AT ANOTHER LOCATION ON-SITE MUST BE HAULED TO AN APPROVED LOCATION OFF-SITE.
2. THE ON-SITE TOPOGRAPHICAL MAPPING WAS PROVIDED BY EMERALD LAND SURVEYING, INC.
3. ALL TEMPORARY OR PERMANENT SLOPES SHALL NOT EXCEED 2H:1V UNLESS APPROVED BY A GEOTECHNICAL ENGINEER.
4. FILL MATERIAL PLACED UNDER BUILDING FOUNDATIONS OR PAVEMENT SHALL BE CRUSHED BASE ROCK OR COMPACTED STRUCTURAL FILL IN ACCORDANCE TO WSDOT STANDARD SPECIFICATIONS.
5. ROCKERY AND/OR RETAINING WALLS GREATER THAN FOUR (4) FEET IN HEIGHT REQUIRES A BUILDING PERMIT.
6. IT WILL BE THE PERMITEE'S RESPONSIBILITY TO SUCCESSFULLY CAP AND ABANDON ALL EXISTING UTILITIES WITHIN THE DEVELOPMENT IN ACCORDANCE TO THE GOVERNING UTILITY AGENCY.

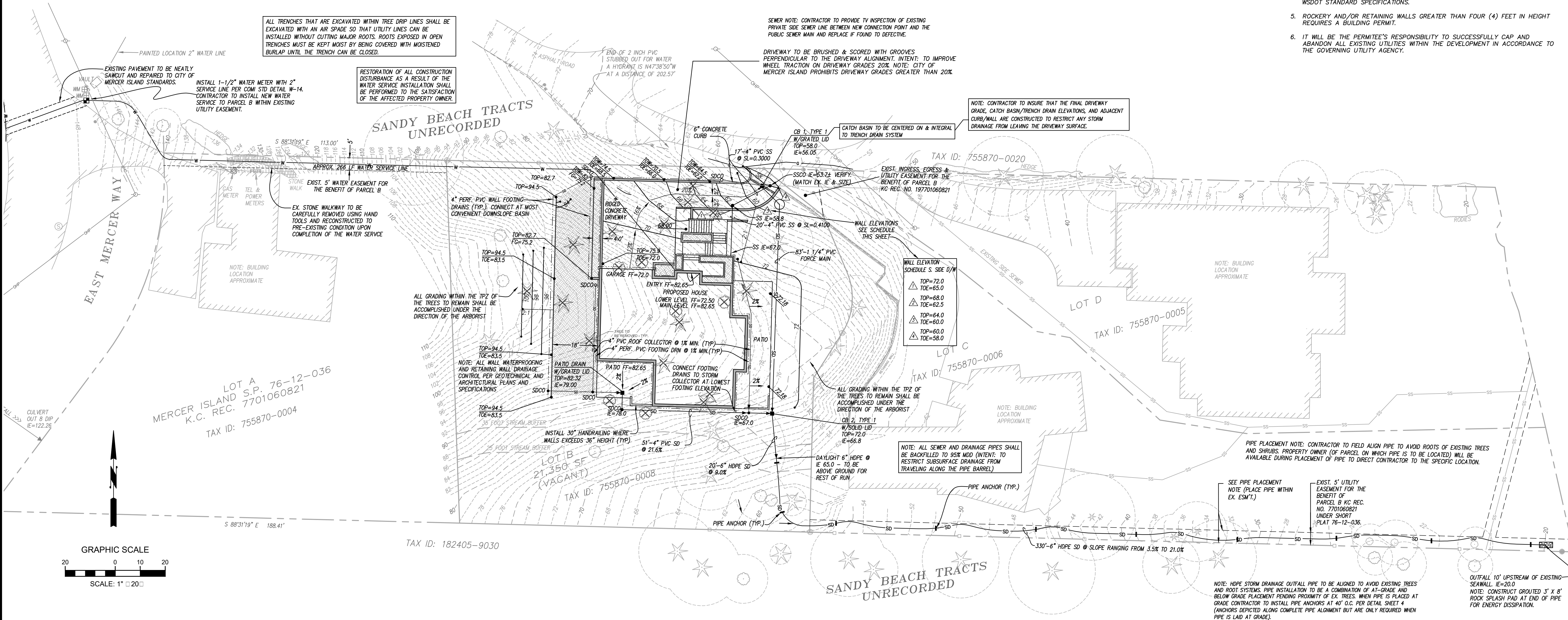

| CHKD BY | DATE | NOTES |
|---------|----------|------------------------------|
| KAL | 6-16-15 | SUBMITTED TO CLIENT |
| KAL | 7-6-15 | REVISED PER CITY COMMENTS |
| KAL | 10-19-15 | REVISED PER CITY COMMENTS |
| KAL | 3-25-16 | ADD EXCAVATION PLAN: SHEET 5 |
| KAL | 5-25-16 | PER CITY COMMENTS |
| KAL | 6-14-17 | UPDATED PER STREAM BUFFER |
| KAL | 10-10-17 | PER CITY COMMENTS |

LITCHFIELD ENGINEERING

12840 81ST AVENUE NE
Kirkland, WA 98034
Tel: (425) 921-3088 Fax: (425) 921-5789

SITE IMPROVEMENT PLAN
BARCELLO HOMES S.F.R.
4634 EAST MERCER WAY
BORDAN MAKSAMCHUK
P.O. BOX 1733
AUBURN, WA 98071

PROJECT CESCL
MICHAEL H. XUE, PE, CESCL
PANGEO, INC.
(206) 262-0374 (O)
(206) 491-0081 (C)

APPROVED: **CITY OF MERCER ISLAND DEVELOPMENT SERVICES GROUP** Date

SHEET
3 of 6

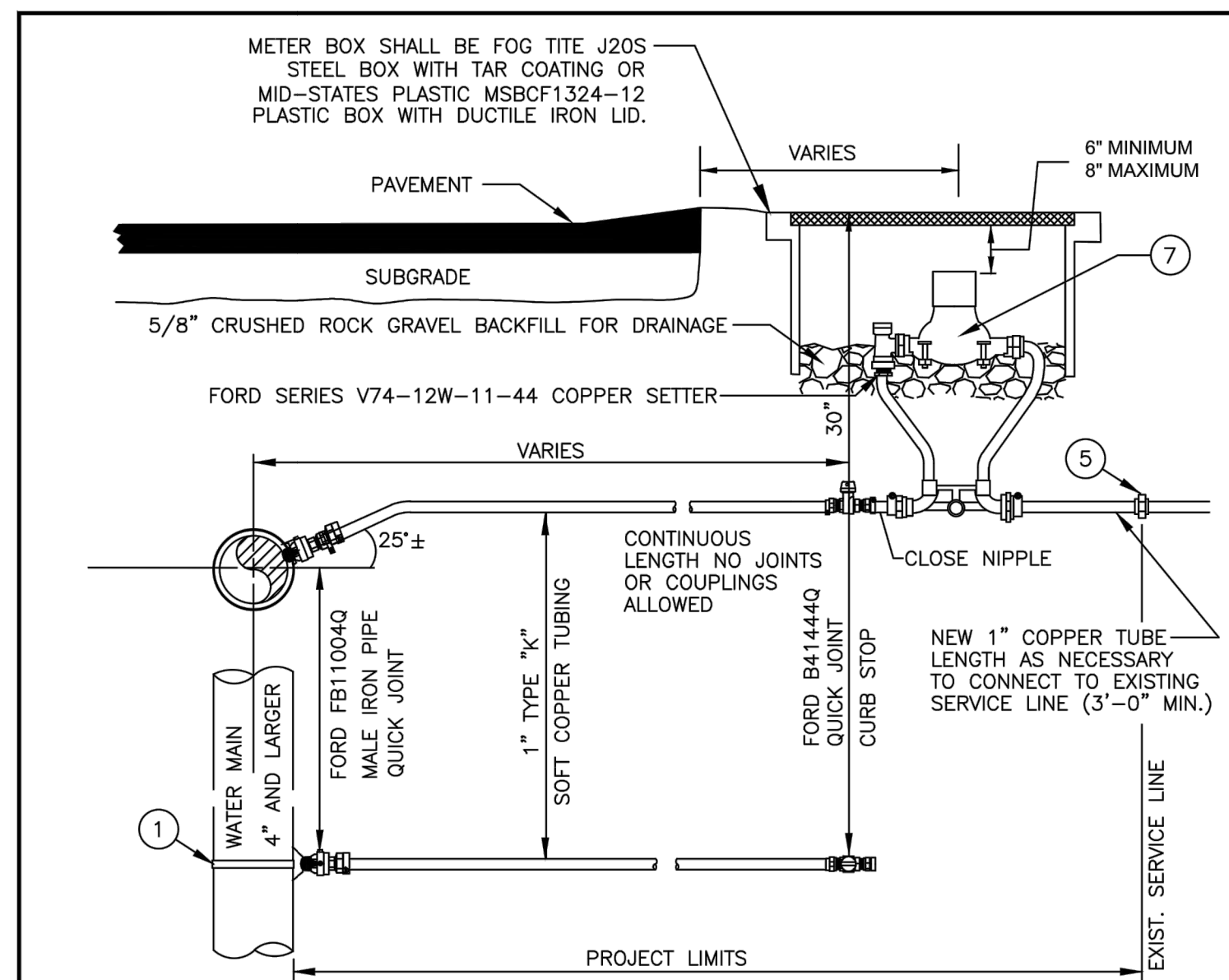

- NOTES**
1. WATER SERVICES SHALL COMPLY WITH THE REDUCTION OF LEAD IN DRINKING WATER ACT DATED 01/04/2014.
 2. ON EXISTING WATER MAINS USE NYLON COATED D.I. SADDLE WITH STAINLESS STEEL SINGLE STRAP, ROMAC 101NS, OR APPROVED EQUAL. ON NEW DUCTILE IRON WATER MAIN 6" DIA. OR LARGER, THE SERVICE MAY BE DIRECTLY TAPPED.
 3. MINIMUM DISTANCE BETWEEN CORP STOPS SHALL BE 18". MINIMUM DISTANCE BETWEEN TAPS, BETWEEN CORP STOP AND PIPE ENDS SHALL BE 24", ALL HORIZONTALLY STAGGERED.
 4. PLASTIC METER BOXES SHALL NOT BE INSTALLED WITHIN ROADWAY, SIDEWALK, OR DRIVEWAYS.
 5. WHEN METER BOXES ARE INSTALLED IN PORTLAND CEMENT CONCRETE PAVEMENT OR SIDEWALK, CONTINUOUS FELT EXPANSION MATERIAL SURROUNDING THE PERIMETER OF THE METER BOX SHALL BE PROVIDED.
 6. WHEN CONNECTING TO EXISTING SERVICE LINE CONTAINING FERROUS METAL, PROVIDE INSULATING COUPLING (DB SERIES WITH C21 SERIES ADAPTERS) AND PROVIDE REDUCER AS NECESSARY TO MATCH EXISTING SERVICE LINE DIAMETER.
 7. SERVICE LINE SHALL BE PERPENDICULAR TO THE WATER MAIN AND STRAIGHT TO WATER METER, UNLESS OTHERWISE APPROVED BY CITY ENGINEER. PROVIDE WINDING SLACK IN THE SERVICE LINE BETWEEN THE MAIN AND WATER METER.
 8. WATER METER SUPPLIED BY CITY.
 9. ALL FITTINGS TO BE BRASS COMPRESSION TYPE, FORD QUICK JOINT OR EQUAL.
 10. NO SERVICE CONNECTIONS BETWEEN BLOW-OFF AND END OF MAIN.

| | | |
|---|------------|-------------|
| CITY OF MERCER ISLAND STANDARD DETAILS WATER | | |
| 1" WATER METER INSTALLATION | | |
| REV DATE | 09-26-2017 | NO SCALE |
| | | W-13 |
| | | APPROVED |

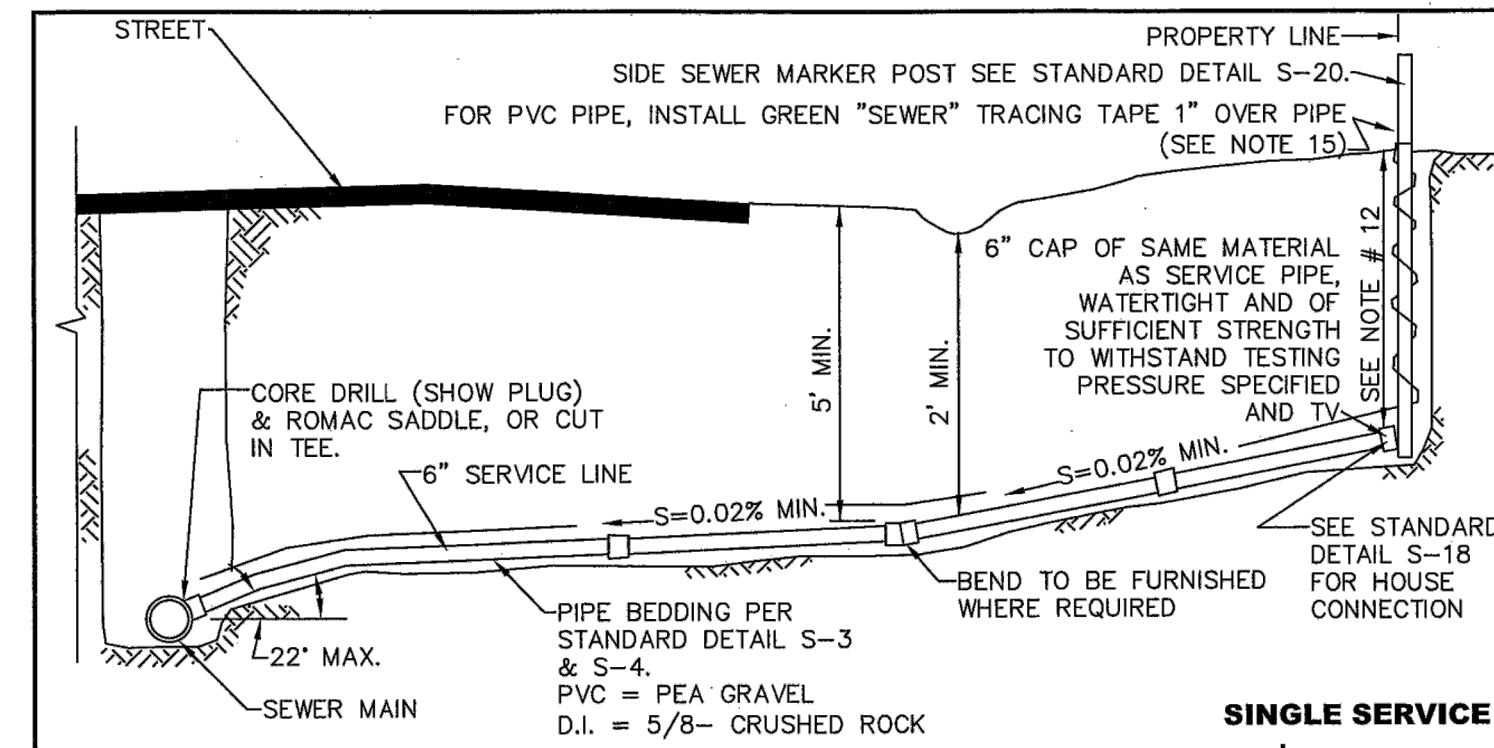

- NOTES**
1. ELBOWS SHALL NOT BE GREATER THAN 45 DEGREES.
 2. CLEAN OUT IS REQUIRED FOR EACH PIPE LENGTH GREATER THAN 100' AND FOR EACH 90° ACCUMULATED ELBOW/100'.
 3. RIGHT-OF-WAY RESTORATION SHALL MATCH OR EXCEED THE ORIGINAL CONDITION AND BE IN ACCORDANCE WITH CITY STANDARDS.
 4. ALL TRENCH BACKFILL IN PUBLIC RIGHT-OF-WAY OR ROADWAY AREAS SHALL BE CRUSHED SURFACING PER WSDOT 9-09.9(3) OR BANK RUN GRAVEL PER WSDOT 9-03.19, COMPACTED IN 6" LIFTS OR MAY BE CDF WHEN DIRECTED BY THE CITY ENGINEER (SEE DETAIL S-3).
 5. LAY PIPE IN STRAIGHT LINE BETWEEN BENDS. MAKE ALL CHANGES IN GRADE OR LINE WITH 1/8" BEND OR WYE. 90° CHANGE WITH 1/8" BEND AND WYE.
 6. 6" SEWER PIPE MINIMUM SIZE IN RIGHT-OF-WAY, AND ELSEWHERE AS DIRECTED BY ENGINEER. 2% MIN. GRADE (UNLESS DIRECTED BY ENGINEER), 50% MAXIMUM.
 7. ALL A.C. MAINS TO BE TAPPED IN ACCORDANCE WITH WAC 296-02-00775 STATE/FEDERAL GUIDELINES AND CERTIFICATION.
 8. CONSTRUCTION IN RIGHT-OF-WAY MUST BE DONE BY A REGISTERED AND LICENSED CONTRACTOR.
 9. ALL CONSTRUCTION SHALL BE IN ACCORDANCE WITH CURRENT CITY SEWER ORDINANCES.
 10. WHERE CITY ENGINEER ALLOWS SIDE SEWER CONNECTIONS TO MANHOLE, INVERT OF SIDE SEWER SHALL BE EQUAL TO OR ABOVE MAIN SEWER CROWN, BUT NOT TO EXCEED 18" ABOVE INVERT OF MAIN SEWER.
 11. UNLESS OTHERWISE INDICATED ON PLAN, SIDE SEWER SHALL BE MIN. OF 6" DEEP AT PROPERTY LINE, OR 5" LOWER THAN THE LOWEST ELEVATION, WHICH EVER IS LOWER.
 12. ALL PIPE MATERIALS NOT TO STANDARDS WILL BE ABANDONED AND REPLACED WITH DUCTILE IRON OR PVC PIPE OF THE SAME SIZE.
 13. IF A BUILDING SEWER IS TO SERVE MORE THAN ONE PROPERTY, BY JOINT AGREEMENT OF THE OWNERS, AN APPROVED EASEMENT INSURING THAT ALL PROPERTIES INVOLVED SHALL HAVE PERPETUAL USE OF THE SIDE SEWER, HAVING PROVISIONS FOR OPERATION, MAINTENANCE, RECONSTRUCTION AND FOR ACCESS FOR REPAIR PURPOSES, SHALL BE SIGNED BY THE OWNERS. THIS EASEMENT SHALL BE RECORDED WITH THE COUNTY AUDITOR. A SIX INCH CLEANOUT EXTENDING TO WITHIN 12 INCHES OF THE GROUND SURFACE SHALL BE PROVIDED AT THE WYE WHERE THE UPPER GRADE CONNECTIONS ARE MADE. BACKWATER VALVES SHALL BE INSTALLED ON SERVICE LINES UPSTREAM OF THE CONNECTION TO THE SHARED SIDE SEWER.
 14. THE CITY ENGINEER MAY REQUIRE BACKWATER VALVES ON SIDE SEWERS WHEN DEEMED NECESSARY. THE EFFECTIVE OPERATION AND MAINTENANCE OF ANY BACKWATER VALVE SHALL BE THE RESPONSIBILITY OF THE OWNER OF THE SIDE SEWER.
 15. UTILITY PIPE TRACER TAPE SHALL BE DETECTABLE BELOW GROUND SURFACE, COLOR CODED, WITH UTILITY NAME PRINTED ON TAPE. CONDUCTIVE WARNING TAPE REQUIRED OVER ALL WATER PIPE. TAPE SHALL BE MANUFACTURER'S STANDARD PERMANENT, BRIGHT-COLORED, CONTINUOUS PRINTED PLASTIC TAPE, ALUMINUM BACKED, INTENDED FOR DIRECT-BURIAL SERVICE. TAPE SHALL BE NOT LESS THAN 6" WIDE X 4 MILS THICK.

| | | |
|---|----------|-------------|
| CITY OF MERCER ISLAND STANDARD DETAILS SEWER | | |
| SIDE SEWER CONNECTION AND STUB | | |
| REV DATE | 6-5-2009 | NO SCALE |
| | | S-17 |
| | | APPROVED |

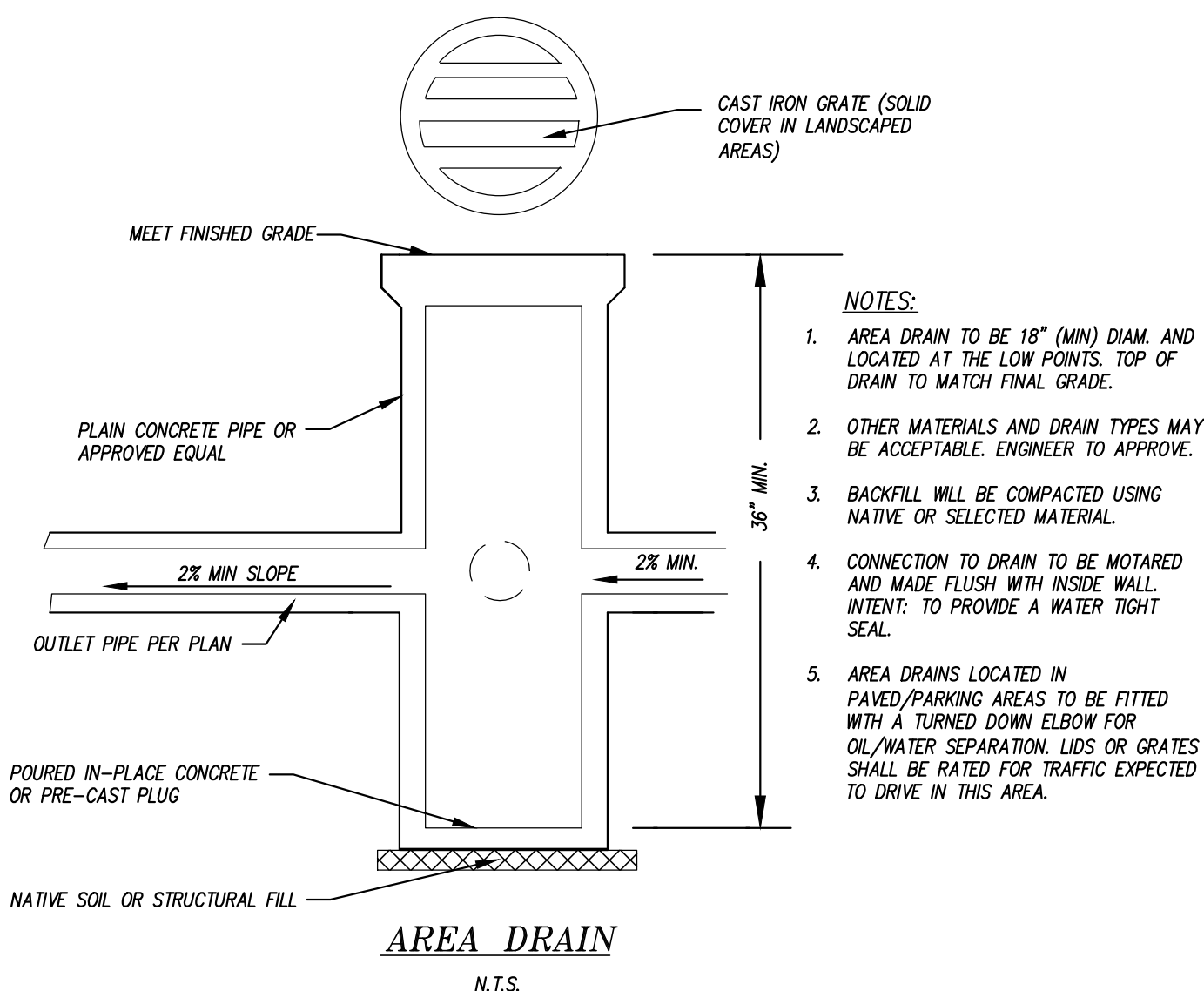
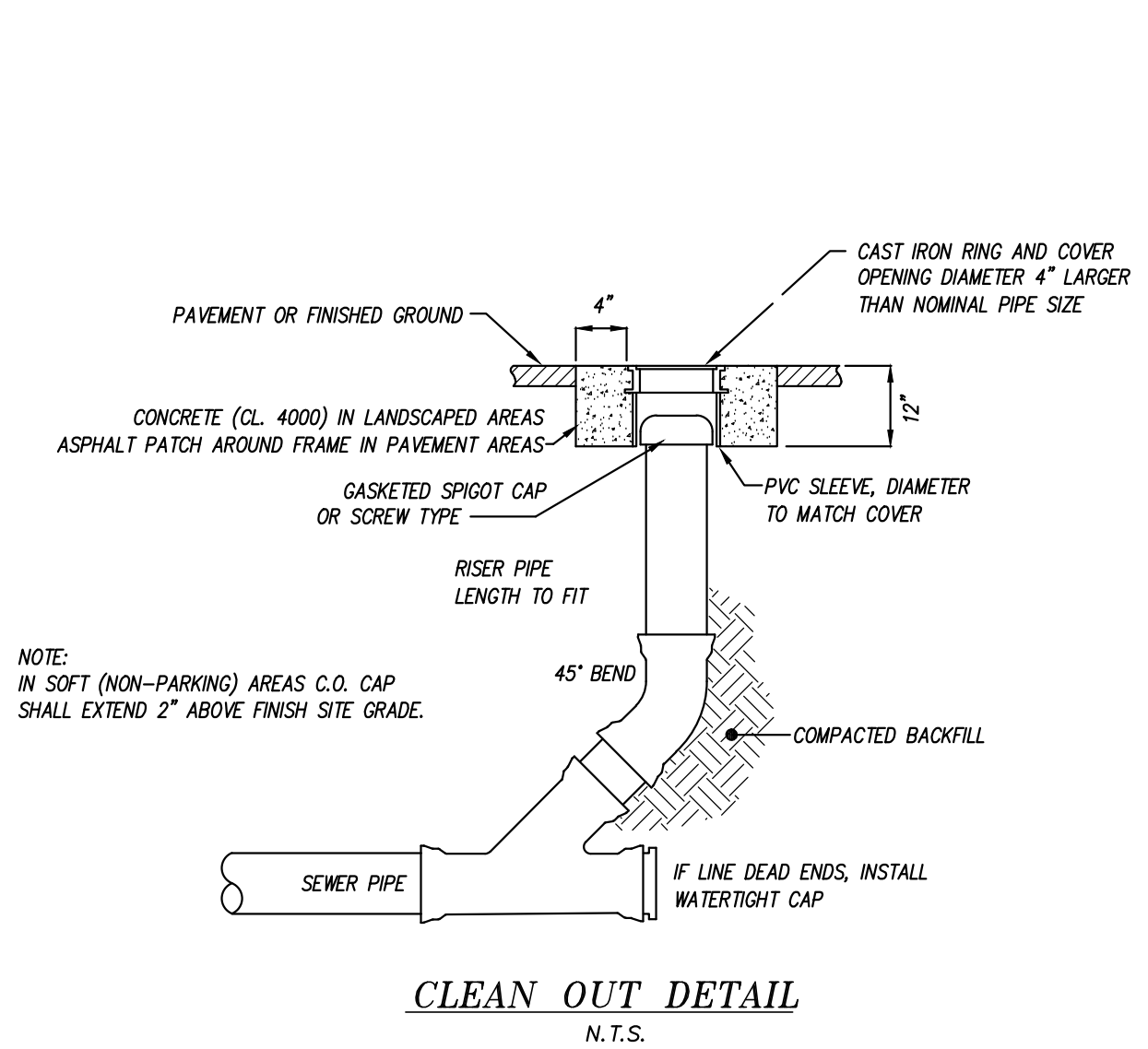

- NOTES:**
1. AREA DRAIN TO BE 18" (MIN) DIAM. AND LOCATED AT THE LOW POINTS, TOP OF DRAIN TO MATCH FINAL GRADE.
 2. OTHER MATERIALS AND DRAIN TYPES MAY BE ACCEPTABLE. ENGINEER TO APPROVE.
 3. BACKFILL WILL BE COMPACTED USING NATIVE OR SELECTED MATERIAL.
 4. CONNECTION TO DRAIN TO BE MOTORED AND MADE FLUSH WITH INSIDE WALL. INTENT: TO PROVIDE A WATER TIGHT SEAL.
 5. AREA DRAINS LOCATED IN PAVED/PARKING AREAS TO BE FITTED WITH A TURNED DOWN ELBOW FOR OIL/WATER SEPARATION. LIDS OR GRATES SHALL BE RATED FOR TRAFFIC EXPECTED TO DRIVE IN THIS AREA.

SECTION 4.2 PIPES, OUTFALLS, AND PUMPS

FIGURE 4.2.1.C CORRUGATED METAL PIPE COUPLING AND/OR GENERAL PIPE ANCHOR ASSEMBLY

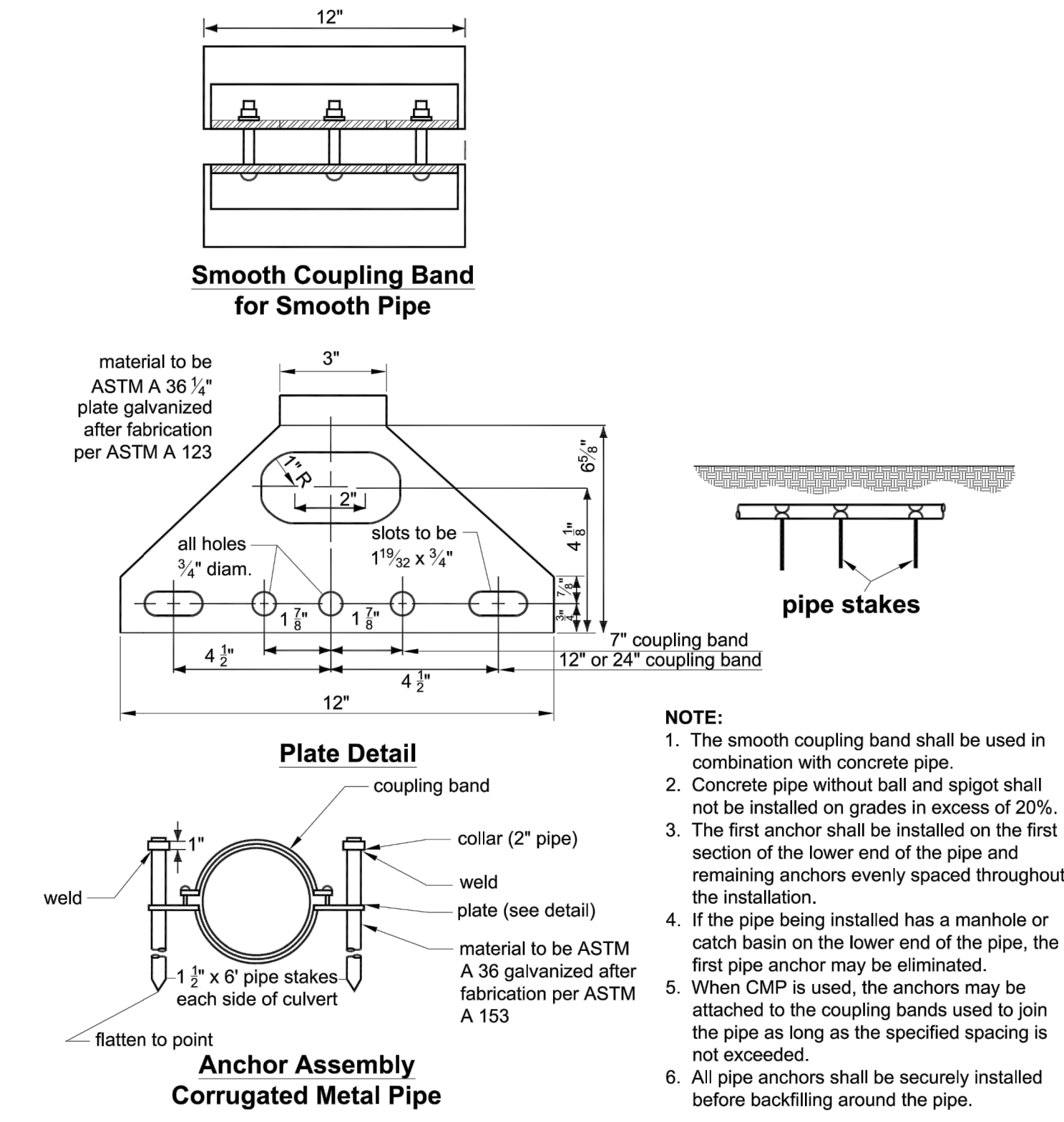

- PUMP SYSTEM SPECIFICATIONS:**
1. PUMP BASIN, CONTROL PANEL, PUMPS, AND ALL ASSOCIATED COMPONENTS SHALL BE BY ORENCO SYSTEMS, INC. TECHNICAL AND/OR INSTALLATION SUPPORT PHONE NUMBER: TRISTAN BOUNDS 800-348-9843, EXT 236. ORDER FROM HD FOWLER: KEVIN GABRIEL 425-746-8400.
 2. PUMP BASIN TO BE 30" DIAMETER WITH LID MOUNTED WITH STAINLESS STEEL SCREWS.
 3. PUMPS TO BE SINGLE PHASE, 230 VOLT, MODEL PSE 15012; CONTROL PANEL TO BE MODEL DAX 2 ETMCT WITH ELAPSED TIME METER AND PUMP COUNTER; FLOAT SWITCHES TO BE MF4A-YP,B,R,W (4 FLOATS REQ'D)

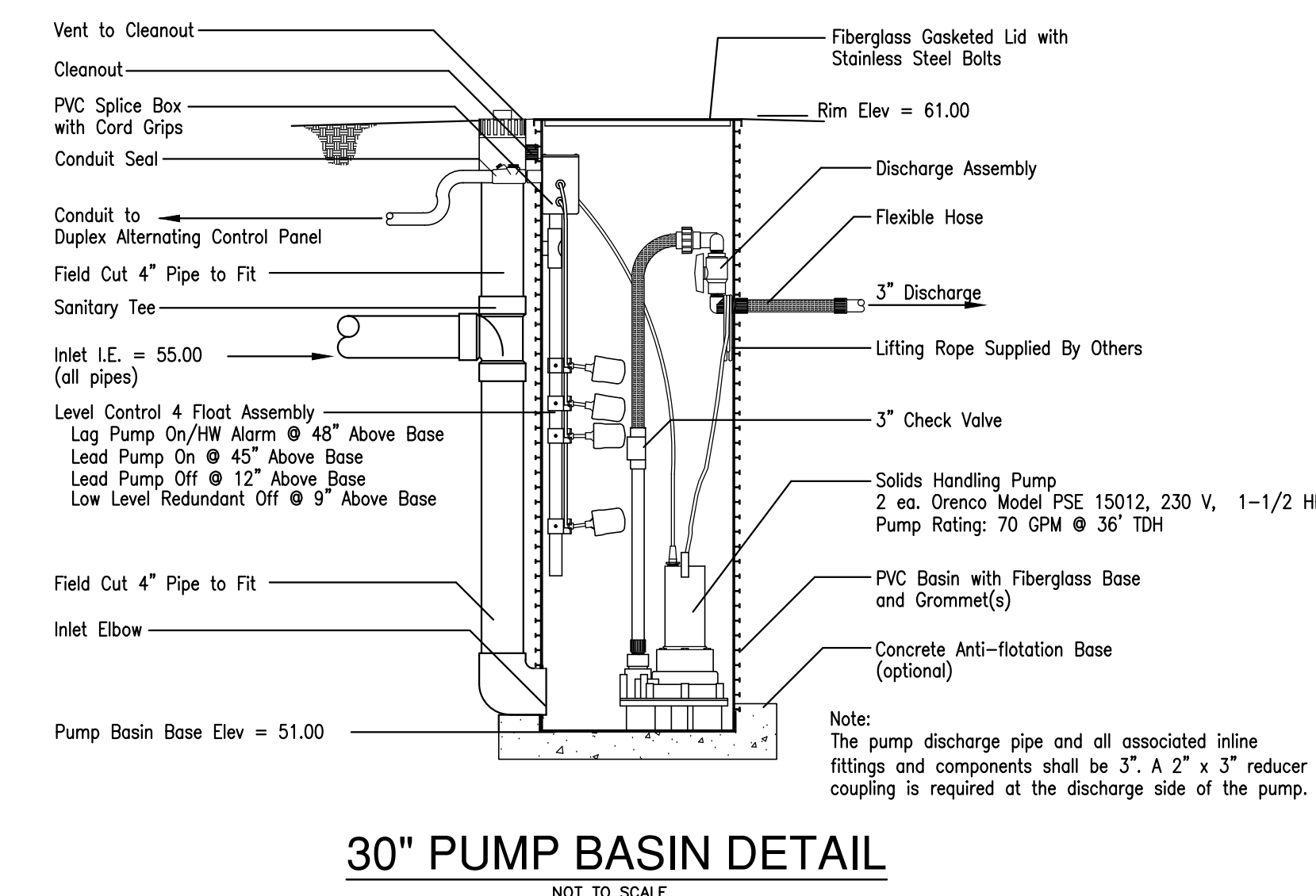

APPROVED: CITY OF MERCER ISLAND DEVELOPMENT SERVICES GROUP Date



| | | | | |
|------------------------------|----------|--|--|--|
| NOTES | | | | |
| SUBMITTED TO CLIENT | 6-16-15 | | | |
| REVISED PER CITY COMMENTS | 10-19-15 | | | |
| ADD EXCAVATION PLAN: SHEET 5 | 3-25-16 | | | |
| REVISED SITE PLAN | 02-09-18 | | | |
| CHKD BY | KAL | | | |
| DATE | | | | |
| DATE | | | | |
| DATE | | | | |
| DATE | | | | |

LITCHFIELD ENGINEERING

12840 81ST AVENUE NE
Kirkland, WA 98034
Tel: (425) 821-2088 Fax: (425) 821-5789

Copyright © 2000 Litchfield Engineering, Inc. All rights reserved.

CONSTRUCTION DETAILS

BARCELLO HOMES SFR.

4634 EAST MERCER WAY

BOGDAN MAKSYMCHUK
BOB 1780071
AUBURN, WA 98007

SPECIAL NOTE TO CONTRACTOR: THE DETAILS & NOTES REGARDING TEMPORARY/PERMANENT CUTS, SOIL STABILIZATION, SOLDIER PILE/RETAINING WALL CONSTRUCTION ARE FOR CONVENIENCE ONLY. CONTRACTOR TO REFER TO STRUCTURAL PLANS & GEOTECHNICAL REPORTS FOR DETAILS & RECOMMENDATIONS.

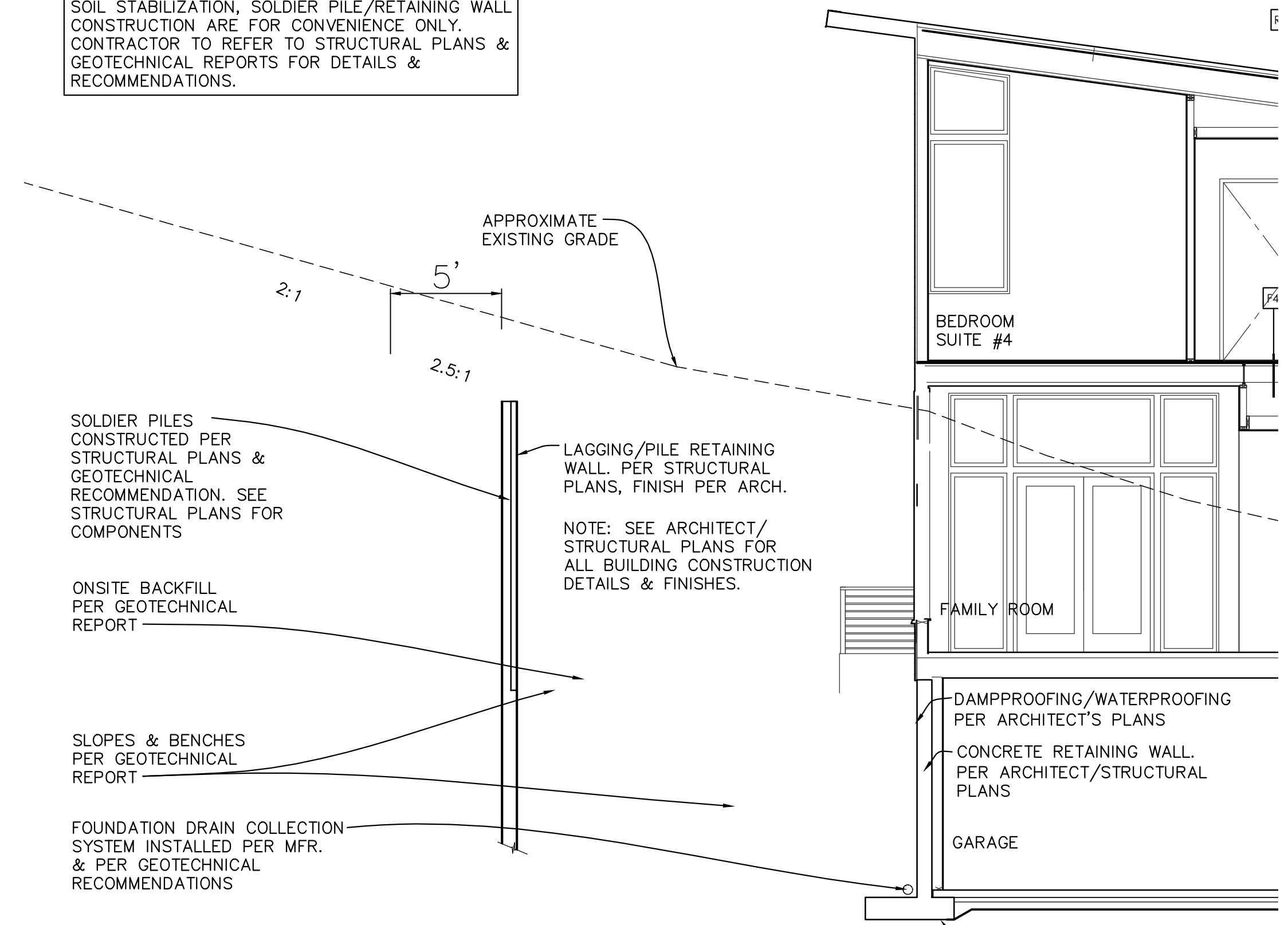

A-A EXCAVATION AT WEST WALL WITH SOLDIER PILES

SCALE: HOR.: 1"=5'; VER.: 1"=5'

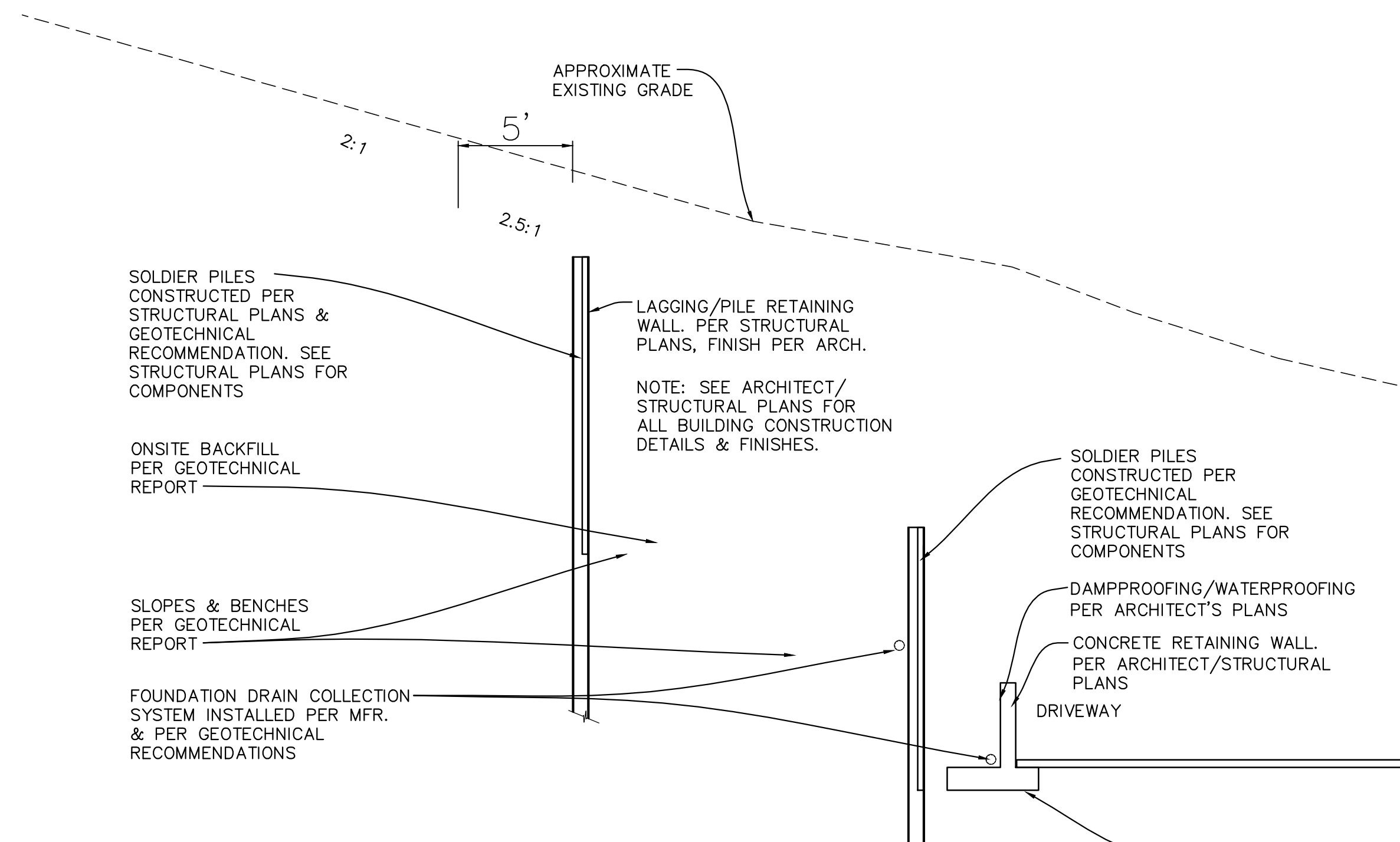

B-B EXCAVATION AT WEST WALL WITH PARALLEL SOLDIER PILES

SCALE: HOR.: 1"=5'; VER.: 1"=5'

SPECIAL GEOTECHNICAL ULTRABLOCK NOTES

- GEOTECHNICAL RECOMMENDATIONS FOR TEMPORARY EXCAVATIONS AND SHORING USING ULTRABLOCKS
1. THE MAXIMUM WALL HEIGHT OF STAGGERED BLOCKS IS 7 1/2 FEET (I.E., 3 BLOCKS IN HEIGHT);
 2. THE VERTICAL WALL FACE IS NO STEEPER THAN 1H (HORIZONTAL):8V (VERTICAL);
 3. THE SUBGRADE AT THE BASE OF THE ULTRABLOCK BLOCKS SHALL CONSIST OF DENSE NATIVE SOIL OR LEVELING CRUSHED ROCK PLACED ON DENSE SOIL;
 4. NO EXCAVATION SHALL BE MADE UNTIL BLOCKS ARE AVAILABLE ON SITE;
 5. THE WIDTH OF UNSUPPORTED CUT FACE FOR BLOCK PLACEMENT SHALL BE LIMITED TO NO MORE THAN ABOUT 10 FEET AT ANY GIVEN TIME;
 6. BLOCKS SHALL BE PLACED IMMEDIATELY AFTER THE CUT IS MADE, OTHERWISE THE CUT FACE SHALL BE BUTTRESSED WITH ON-SITE SOILS UNTIL THE BLOCKS CAN BE PLACED;
 7. ANY VOIDS BEHIND BLOCKS SHALL BE BACKFILLED WITH GRAVEL IMMEDIATELY AFTER THE BLOCK WALL ARE INSTALLED; AND
 8. PANGEO SHALL PROVIDE FULL TIME OBSERVATION DURING BLOCK WALL INSTALLATION.

GEOTECHNICAL ENGINEER TO REVIEW THESE PLANS AND COORDINATE WITH CONTRACTOR ON ALL EXCAVATION, FOUNDATION DRAINAGE, RETAINING WALLS, SHEET PILING, SHORING, ULTRABLOCK, BACKFILLING AND OTHER EARTHWORK NECESSARY TO CONSTRUCT THIS PROJECT.

THIS PROJECT REQUIRES STAGED FOUNDATION CONSTRUCTION, CONTRACTOR TO WORK WITH GEOTECHNICAL ENGINEER TO DETERMINE THE APPROPRIATE LIMITS AND PROCESSES FOR SUCCESSIVE STAGES OF THE CONSTRUCTION.

CONTRACTOR TO COORDINATE WITH ARCHITECT & STRUCTURAL ENGINEER ON ALL PENETRATIONS THROUGH RETAINING WALLS, PROVIDING SLEEVES WHERE SHOWN OR REQUIRED.

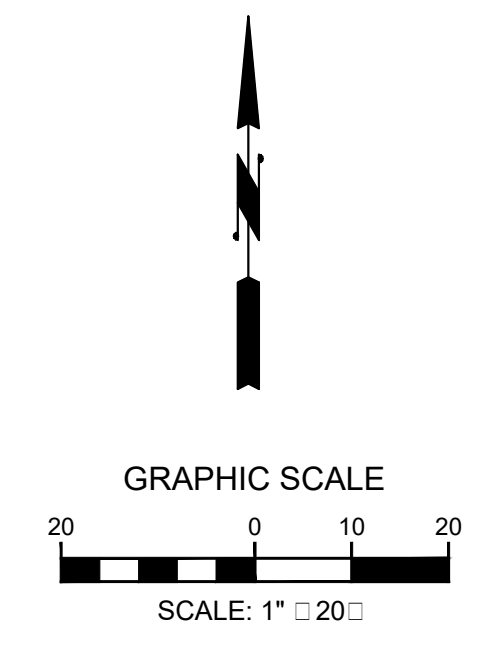
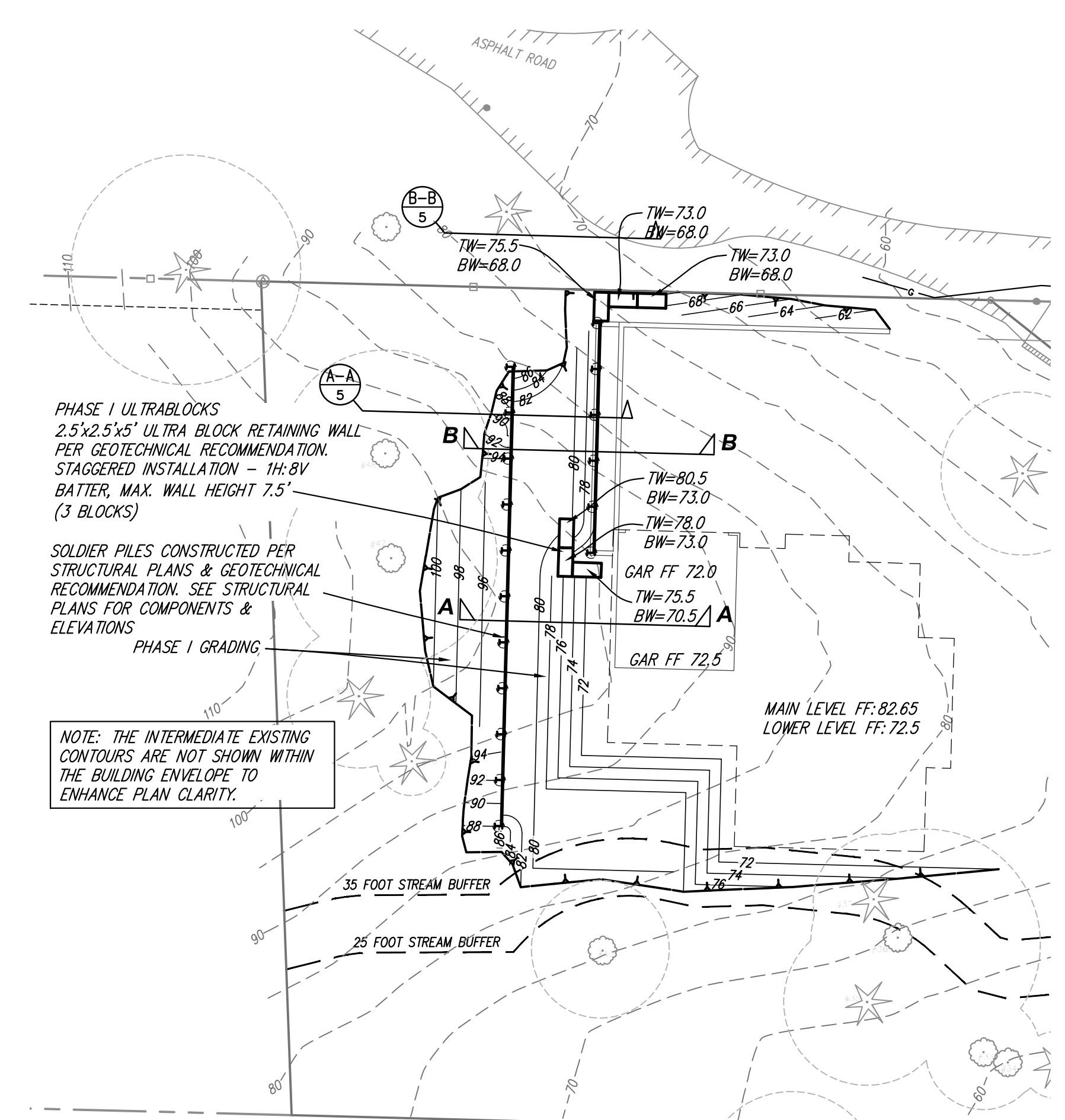

PROJECT CESCL
MICHAEL H. XUE, PE, CESCL
PANGEO, INC.
(206) 262-0374 (O)
(206) 491-0081 (C)

APPROVED: CITY OF MERCER ISLAND DEVELOPMENT SERVICES GROUP Date



| DATE | CHKD BY | DIVL BY | NOTES |
|----------|---------|---------|-----------------------------|
| 1-29-16 | KAL | KAL | PER STRUCTURAL REVISION |
| 3-9-16 | KAL | KAL | PER ARCH/STRUCT/GEOTECH |
| 3-25-16 | KAL | KAL | ADD EXCAVATION PLAN SHEET 5 |
| 5-25-16 | KAL | KAL | PER CITY COMMENTS |
| 6-14-17 | KAL | KAL | UPDATED PER STREAM BUFFER |
| 10-10-17 | KAL | KAL | PER CITY COMMENTS |

LITCHFIELD ENGINEERING
12840 81ST AVENUE NE
Kirkland, WA 98034
Tel: (425) 821-2088 Fax: (425) 821-5789

TEMPORARY EXCAVATION PLAN
BARCELLO HOMES SFR.
4634 EAST MERCER WAY
BOGDAN MAKSYMCHUK
BOB LITVIN
AUBURN, WA 98007

CALL 3 WORKING DAYS BEFORE YOU DIG
811
UTILITIES UNDERGROUND LOCATION CENTER
(800) 487-4874

ELECTRIC-RED SEWER-GREEN GASOL-YELLOW WATER-BLUE
 TELECOM-ORANGE PROPOSED-WHITE WATER-ORANGE

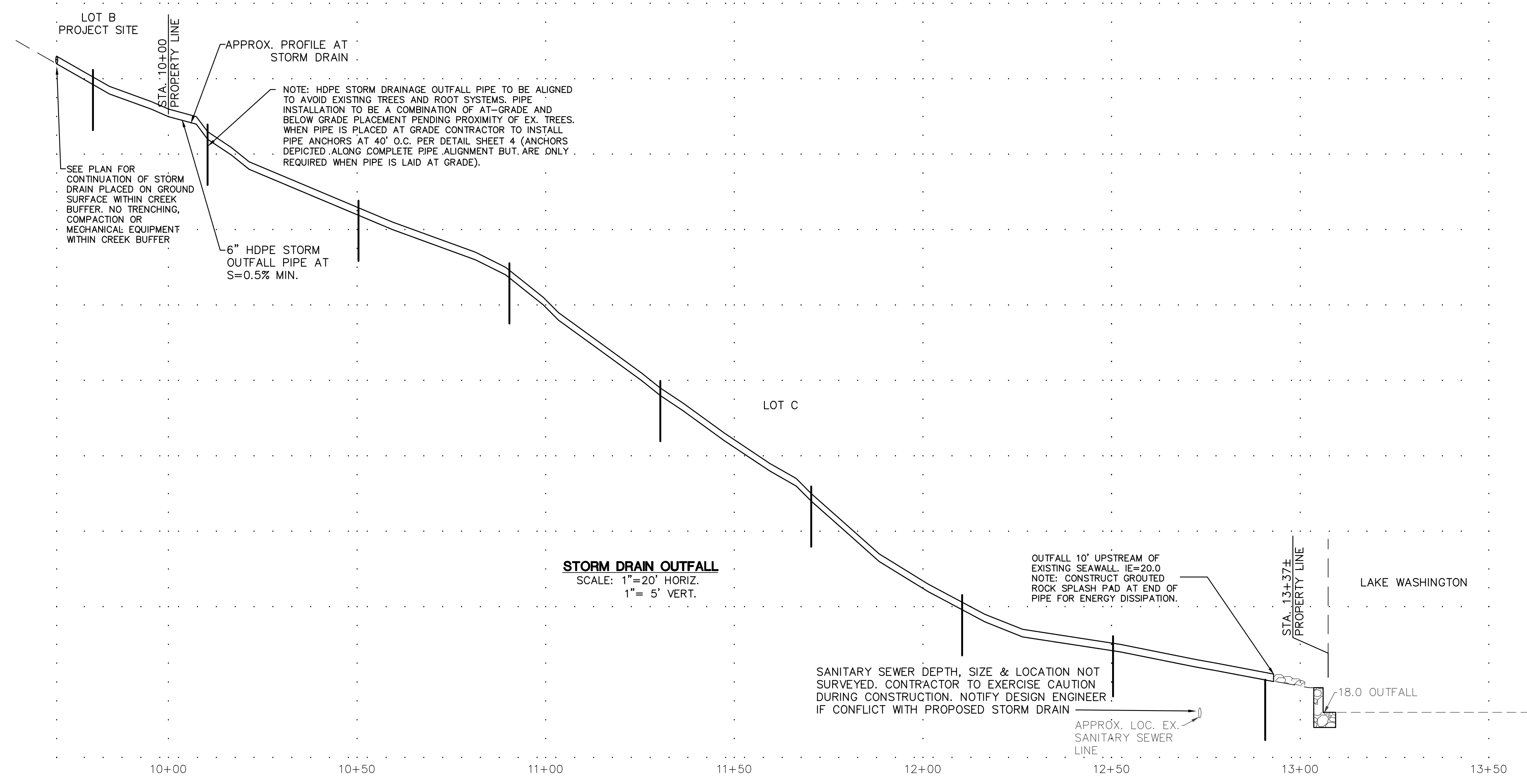

LOT B
PROJECT SITE

SEE PLAN FOR
CONTINUATION OF STORM
DRAIN PLACED ON GROUND
SURFACE WITHIN CREEK
BUFFER. NO TRENCHING,
COMPACTION OR
MECHANICAL EQUIPMENT
WITHIN CREEK BUFFER

APPROX. PROFILE AT
STORM DRAIN

NOTE: HDPE STORM DRAINAGE OUTFALL PIPE TO BE ALIGNED
TO AVOID EXISTING TREES AND ROOT SYSTEMS. PIPE
INSTALLATION TO BE A COMBINATION OF AT-GRADE AND
BELOW GRADE PLACEMENT PENDING PROXIMITY OF EX. TREES.
WHEN PIPE IS PLACED AT GRADE CONTRACTOR TO INSTALL
PIPE ANCHORS AT 40' O.C. PER DETAIL SHEET 4 (ANCHORS
DEPICTED ALONG COMPLETE PIPE ALIGNMENT BUT ARE ONLY
REQUIRED WHEN PIPE IS LAID AT GRADE).

6" HDPE STORM
OUTFALL PIPE AT
S=0.5% MIN.

STORM DRAIN OUTFALL
SCALE: 1"=20' HORIZ.
1"= 5' VERT.

LOT C

OUTFALL 10' UPSTREAM OF
EXISTING SEAWALL. IE=20.0
NOTE: CONSTRUCT GROUDED
ROCK SPLASH PAD AT END OF
PIPE FOR ENERGY DISSIPATION.

SANITARY SEWER DEPTH, SIZE & LOCATION NOT
SURVEYED. CONTRACTOR TO EXERCISE CAUTION
DURING CONSTRUCTION. NOTIFY DESIGN ENGINEER
IF CONFLICT WITH PROPOSED STORM DRAIN

APPROX. LOC. EX.
SANITARY SEWER
LINE

STA. 13+37±
PROPERTY LINE

LAKE WASHINGTON

18.0' OUTFALL

10+00 10+50 11+00 11+50 12+00 12+50 13+00 13+50



| DATE | CHKD BY | DWN BY | NOTES |
|---------|---------|--------|----------------------|
| 5-25-16 | KAL | KAL | ADD PROFILE: SHEET 6 |
| | | | |
| | | | |

LITCHFIELD ENGINEERING
12840 81ST AVENUE NE
Kirkland, WA 98034
Tel: (425) 821-5088 Fax: (425) 821-5789

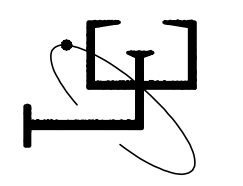

STORM DRAIN OUTFALL PROFILE
BARCELLO HOMES S.F.R.
4634 EAST MERCER WAY
BODAN MAKSYMCHUK
P.O. BOX 1733
AUBURN, WA, 98071

APPROVED: _____
CITY OF MERCER ISLAND DEVELOPMENT SERVICES GROUP Date

SHEET
6 of 6

SITE SLOPE CALCULATION

| | | |
|--|--|--|
| NORTH PROPERTY LINE LOWEST POINT = 56.8' HIGHEST POINT = 92.0' | MID PROPERTY LOWEST POINT = 67.5' HIGHEST POINT = 110.0' | SOUTH PROPERTY LINE LOWEST POINT = 56.8' HIGHEST POINT = 79.0' |
| DIFFERENCE = 35.2' | DIFFERENCE = 42.5' | DIFFERENCE = 22.2' |
| DISTANCE = 127.00' | DISTANCE = 140.80' | DISTANCE = 140.00' |
| 35.2 / 127.0 = 27.71% LOT SLOPE | 42.5 / 140.80 = 26.43% LOT SLOPE | 22.2 / 140.0 = 15.88% LOT SLOPE |

NOTE:
REFER TO CIVIL SHEET 3 OF 4 FOR INFORMATION REGARDING
WATER SERVICE, GAS SERVICE, ELECTRICAL SERVICE, SANITARY
SEWER, AND STORM DRAINAGE

END OF 2 INCH PVC
STUBBED OUT FOR WATER
A HYDRANT IS N47°38'50"W
AT A DISTANCE OF 202.57'

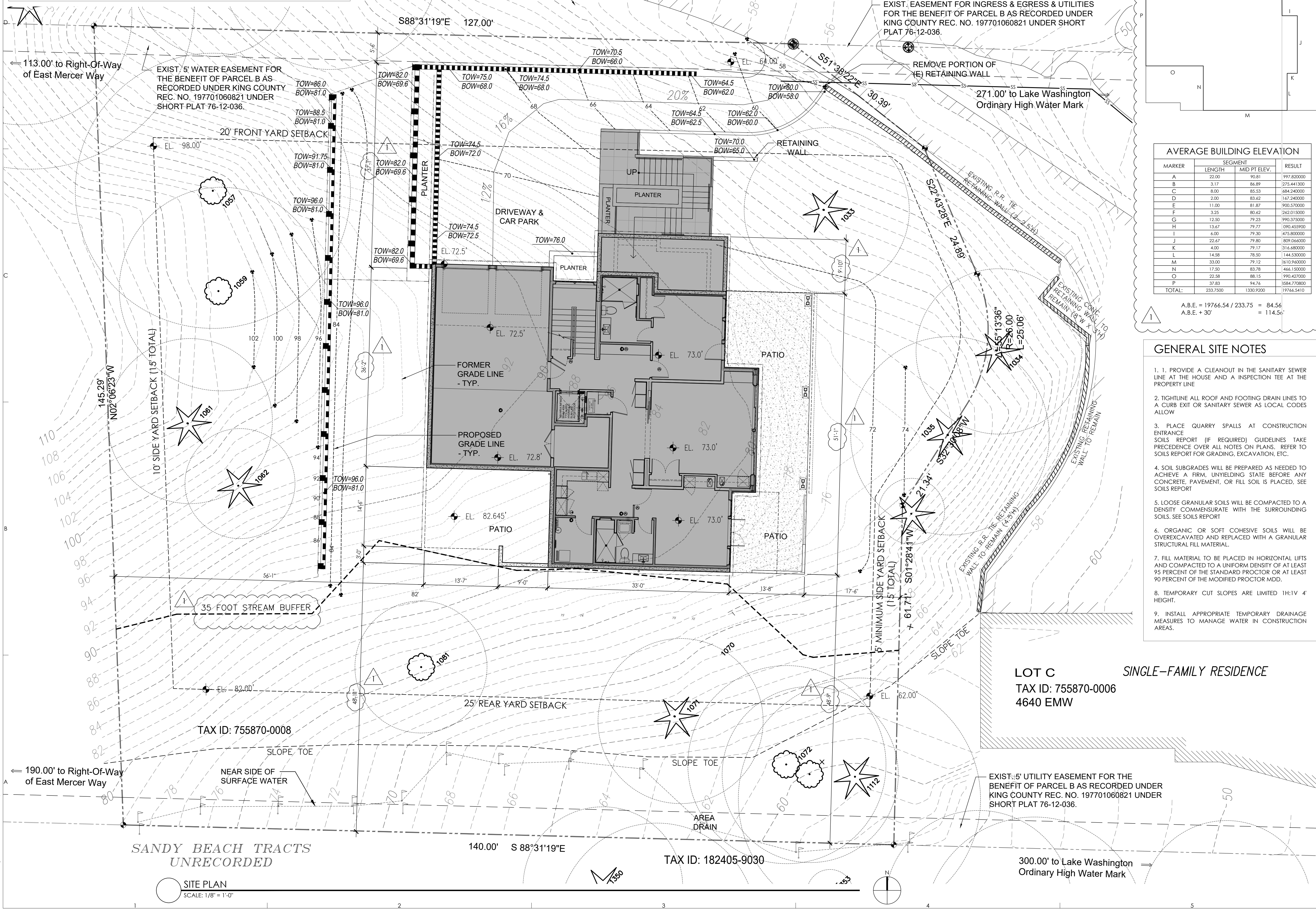

AVERAGE BUILDING ELEVATION

| MARKER | SEGMENT | MID PT. ELEV. | RESULT |
|--------|----------|---------------|-------------|
| A | 22.00 | 90.81 | 997.820000 |
| B | 3.17 | 86.89 | 275.441300 |
| C | 8.00 | 85.53 | 684.240000 |
| D | 2.00 | 83.62 | 167.240000 |
| E | 11.00 | 81.87 | 900.370000 |
| F | 3.25 | 80.42 | 262.015000 |
| G | 12.50 | 79.23 | 990.375000 |
| H | 13.67 | 79.77 | 090.455900 |
| I | 6.00 | 79.30 | 475.800000 |
| J | 22.67 | 79.80 | 809.066000 |
| K | 4.00 | 79.17 | 316.480000 |
| L | 14.58 | 78.50 | 144.530000 |
| M | 33.00 | 79.12 | 3610.960000 |
| N | 17.50 | 83.78 | 466.150000 |
| O | 22.58 | 88.15 | 990.427000 |
| P | 37.83 | 94.76 | 1584.770000 |
| TOTAL: | 233.7500 | 1330.9200 | 19766.5410 |

A.B.E. = 19766.54 / 233.75 = 84.56'
A.B.E. + 30' = 114.56'

- GENERAL SITE NOTES**
1. PROVIDE A CLEANOUT IN THE SANITARY SEWER LINE AT THE HOUSE AND AN INSPECTION TEE AT THE PROPERTY LINE
 2. TIGHTLINE ALL ROOF AND FOOTING DRAIN LINES TO A CURB EXIT OR SANITARY SEWER AS LOCAL CODES ALLOW
 3. PLACE QUARRY SPALLS AT CONSTRUCTION ENTRANCE
SOILS REPORT (IF REQUIRED) GUIDELINES TAKE PRECEDENCE OVER ALL NOTES ON PLANS, REFER TO SOILS REPORT FOR GRADING, EXCAVATION, ETC.
 4. SOIL SUBGRADES WILL BE PREPARED AS NEEDED TO ACHIEVE A FIRM, UNYIELDING STATE BEFORE ANY CONCRETE, PAVEMENT, OR FILL SOIL IS PLACED, SEE SOILS REPORT
 5. LOOSE GRANULAR SOILS WILL BE COMPACTED TO A DENSITY COMMENSURATE WITH THE SURROUNDING SOILS. SEE SOILS REPORT
 6. ORGANIC OR SOFT COHESIVE SOILS WILL BE OVEREXCAVATED AND REPLACED WITH A GRANULAR STRUCTURAL FILL MATERIAL.
 7. FILL MATERIAL TO BE PLACED IN HORIZONTAL LIFTS AND COMPACTED TO A UNIFORM DENSITY OF AT LEAST 95 PERCENT OF THE STANDARD PROCTOR OR AT LEAST 90 PERCENT OF THE MODIFIED PROCTOR MDD.
 8. TEMPORARY CUT SLOPES ARE LIMITED 1H:1V 4' HEIGHT.
 9. INSTALL APPROPRIATE TEMPORARY DRAINAGE MEASURES TO MANAGE WATER IN CONSTRUCTION AREAS.

CONSULTANT: _____

PROFESSIONAL SEAL: _____



PROJECT: _____

a project for:
Barcelo homes
PO BOX 1733 AUBURN, WA 98071
Phone: (206) 724-1072

EAST MERCER RESIDENCE

4634 EAST MERCER WAY
MERCER ISLAND, WA 98040

SHEET ISSUE: _____

| | |
|------------|--------------------|
| 6/24/2015 | PERMIT SUBMITTAL |
| 8/29/2016 | PERMIT APPROVED |
| 6/05/2017 | REVISION TO PERMIT |
| 05/08/2018 | REVISION TO PERMIT |

MUNICIPALITY REVIEW: _____

PROJECT # MERCER ISLAND 15 - 015

SHEET TITLE: _____

SITE PLAN

PROJECT NO.: 20140904

DATE ISSUED: 05/08/2018

SHEET NUMBER: _____

A1.01
Exhibit 5

File: A1.01_SitePlan.dwg / Sheet: A1.01 / Plot Date: May 8, 2018

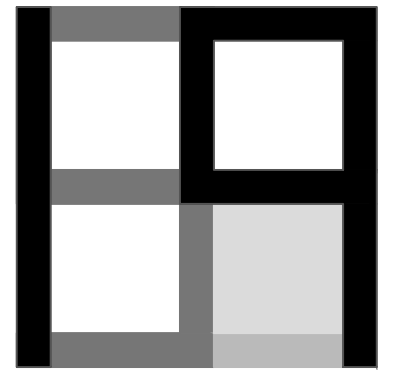

NOTE:
REFER TO CIVIL SHEET 3 OF 4 FOR INFORMATION REGARDING
WATER SERVICE, GAS SERVICE, ELECTRICAL SERVICE, SANITARY
SEWER, AND STORM DRAINAGE

TREE PLAN KEY NOTES

1. TREE PROTECTION FENCING AT DRIP LINE
2. ALL TRENCHES THAT ARE EXCAVATED WITHIN TREE DRIP LINES SHALL BE EXCAVATED WITH AN AIR SPADE SO THAT UTILITY LINES CAN BE INSTALLED WITHOUT CUTTING MAJOR ROOTS.
3. ROOTS EXPOSED IN OPEN TRENCHES MUST BE KEPT MOIST BY BEING COVERED WITH MOISTENED BURLAP UNTIL THE TRENCH CAN BE CLOSED.

TREE INVENTORY (SEE ARBORIST REPORT)

| EXISTING ON SITE TREES | | REMOVE/RETAIN |
|------------------------|---------------------|------------------------|
| ARB SURVEY # | SPECIES | REMOVE/RETAIN |
| 21 | 1030 DOUGLAS FIR | 36" 26' G REMOVE |
| 22 | 1029 DOUGLAS FIR | 43" 27' G REMOVE |
| 23 | 1028 DOUGLAS FIR | 26" 23' G REMOVE |
| 24 | 1033 DOUGLAS FIR | 43" 23' F RETAIN |
| 25 | 1034 DOUGLAS FIR | 30" 15' G RETAIN |
| 26 | 1035 DOUGLAS FIR | 37" 18' G RETAIN |
| 27 | 1047 DOUGLAS FIR | 37" 21' F REMOVE |
| 28 | 1048 SWEET CHERRY | 8" 22' G REMOVE |
| 29 | 1052 BIGLEAF MAPLE | 36" 30' G REMOVE |
| 30 | 1053 WSTRN RD CEDAR | 9" 13' G REMOVE |
| 31 | 1054 SITKA SPRUCE | 5" 6' P REMOVE |
| 32 | 1112 WSTRN HEMLOCK | 20" 22' G RETAIN |
| 33 | 1072 BIGLEAF MAPLE | 14" 18' G RETAIN |
| 34 | 1072X BIGLEAF MAPLE | 8" 16' F RETAIN |
| 35 | 1071 BIGLEAF MAPLE | 38" 20' F RETAIN |
| 36 | 1070 BIGLEAF MAPLE | 9'6" 20' F RETAIN |
| 37 | 1069 WSTRN RD CEDAR | 15" 12' E RETAIN |
| 38 | 1067 WSTRN RD CEDAR | 41" 16' G REMOVE |
| 39 | 1066 BIGLEAF MAPLE | 32" 35' G REMOVE |
| 40 | 1061 BIGLEAF MAPLE | 18" 18' G RETAIN |
| 41 | 1065 BIGLEAF MAPLE | 34" 35' G REMOVE |
| 42 | 1064 DOUGLAS FIR | 44" 20' F REMOVE |
| 43 | 1063 DOUGLAS FIR | 31" 20' F REMOVE |
| 44 | 1060 DOUGLAS FIR | 34" 23' G REMOVE |
| 45 | 1061 DOUGLAS FIR | 33" 15' G RETAIN |
| 46 | 1062 DOUGLAS FIR | 13" 10' G RETAIN |
| 47 | 1059 BIGLEAF MAPLE | 31" 28' E RETAIN |
| 48 | 1058 BIGLEAF MAPLE | 34" 40' G RETAIN |
| 49 | 1056 DOUGLAS FIR | 13" 20' F REMOVE |
| 50 | 1054 BIGLEAF MAPLE | 40" 11" 35' G,F REMOVE |
| 51 | 1051 BIGLEAF MAPLE | 10" 25' F REMOVE |
| 52 | 1053 WSTRN HEMLOCK | 10" 15' F REMOVE |
| 53 | 1050 BIGLEAF MAPLE | 14" 18' F RETAIN |
| A | --- | 4" 6" P RETAIN |

EXISTING OFF SITE TREES

| LOT SURVEY # | SPECIES | DBH | DRIP | REMOVE/RETAIN |
|-----------------------------------|---------|-----|------|----------------------|
| 4624 1023 | MAPLE | 6" | 15' | NORTH OF SITE RETAIN |
| 4624 1024 | CEDAR | 14" | 20' | NORTH OF SITE RETAIN |
| LOT A 1175 | CEDAR | 48" | 35' | RETAIN |
| LOT A 1234 | DECID. | 4" | 9" | RETAIN |
| LOT A 1339 | DECID. | 4" | 7" | RETAIN |
| LOT D 1308 | CEDAR | 38" | 20' | RETAIN |
| LOT D 1329 | CEDAR | 22" | 16' | RETAIN |
| LOT D 1326 | DECID. | 10" | 6" | RETAIN |
| LOT D 1344 | CEDAR | 24" | 10' | RETAIN |
| LOT D 1346 | CEDAR | 22" | 9" | RETAIN |
| LOT D 1347 | CEDAR | 18" | 8" | RETAIN |
| LOT D 1348 | CEDAR | 18" | 10' | RETAIN |
| LOT D 1349 | CEDAR | 26" | 9" | RETAIN |
| ESTIMATED (COULD NOT GAIN ACCESS) | | | | |
| 4644 1350 | CEDAR | 22" | 20' | RETAIN |
| 4644 1351 | CEDAR | 18" | 16' | RETAIN |
| 4644 1352 | DECID. | 8" | 10' | RETAIN |
| 4644 1353 | CEDAR | 6" | 4" | RETAIN |
| 4644 1354 | CEDAR | 22" | 15' | RETAIN |
| 4644 1355 | CEDAR | 16" | 10' | RETAIN |
| 4644 1356 | CEDAR | 22" | 15' | RETAIN |
| 4644 1357 | CEDAR | 26" | 18' | RETAIN |
| 4644 1358 | CEDAR | 12" | 12' | RETAIN |
| 4644 1359 | CEDAR | 22" | 16' | RETAIN |
| 4644 1360 | DECID. | 6" | 7" | RETAIN |
| 4644 1361 | DECID. | 10" | 9" | RETAIN |
| 4644 1362 | DECID. | 8" | 6" | RETAIN |

TOTAL ON SITE TREES TO BE REMOVED : 20
TOTAL ON SITE TREES TO REMAIN : 14
TOTAL OFF SITE TREES TO BE REMOVED : 0
SEE ARBORIST REPORT FOR MORE INFORMATION.

CONSULTANT: _____

PROFESSIONAL SEAL: _____

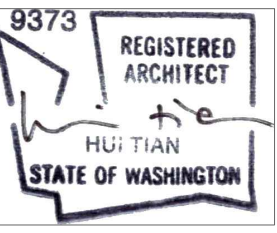

PROJECT: _____

a project for:

PO BOX 1733 AUBURN, WA 98071
Phone: (206) 724-1072

EAST MERCER RESIDENCE

4634 EAST MERCER WAY
MERCER ISLAND, WA 98040

SHEET ISSUE: _____

| | |
|------------|--------------------|
| 6/24/2015 | PERMIT SUBMITTAL |
| 8/29/2016 | PERMIT APPROVED |
| 6/05/2017 | REVISION TO PERMIT |
| 05/08/2018 | REVISION TO PERMIT |

MARK DATE DESCRIPTION

MUNICIPALITY REVIEW: _____

PROJECT # MERCER ISLAND 15 - 015

SHEET TITLE: _____

TREE PLAN

PROJECT NO.: 20140904

DATE ISSUED: 05/08/2018

SHEET NUMBER: _____

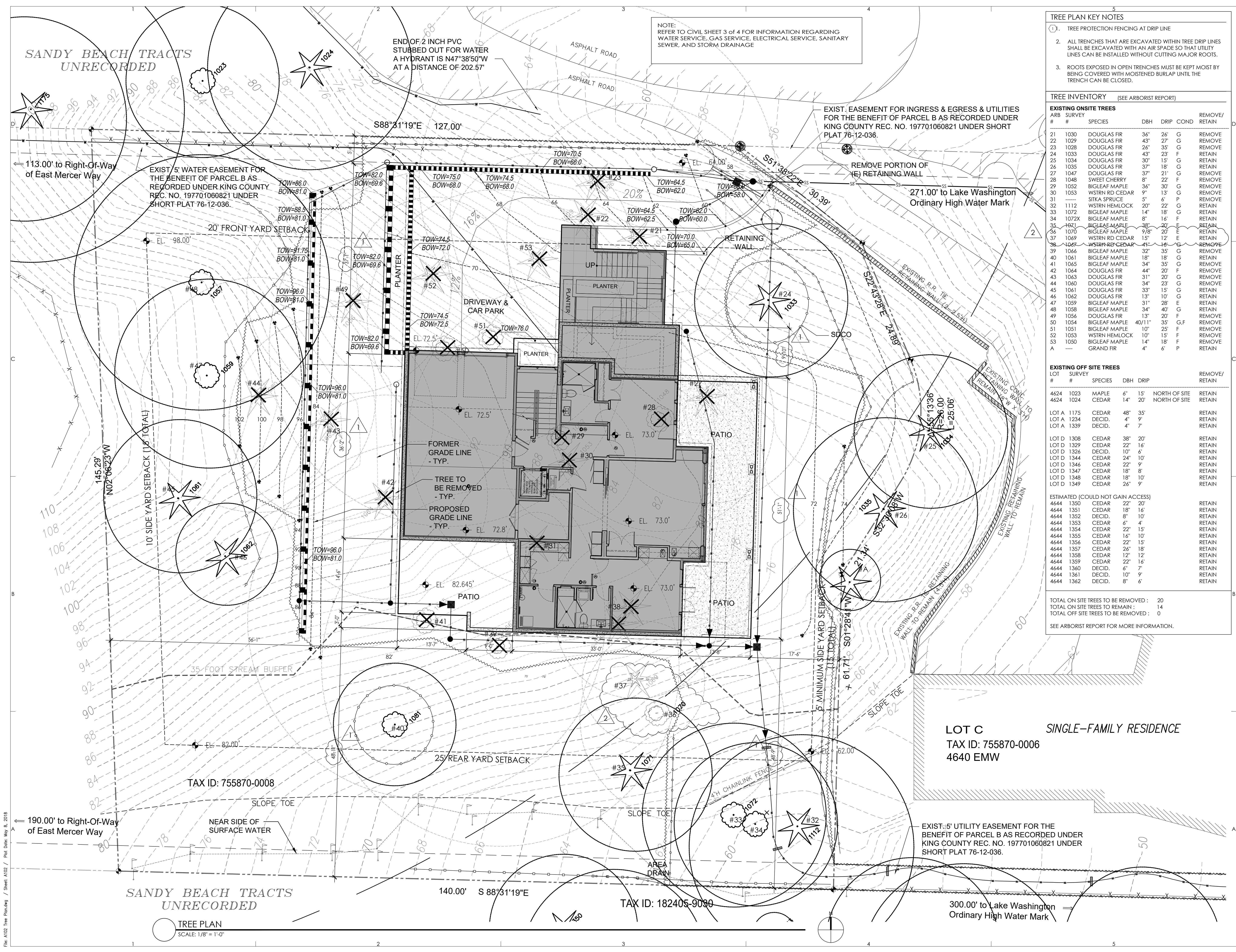

TREE PLAN
SCALE: 1/8" = 1'-0"

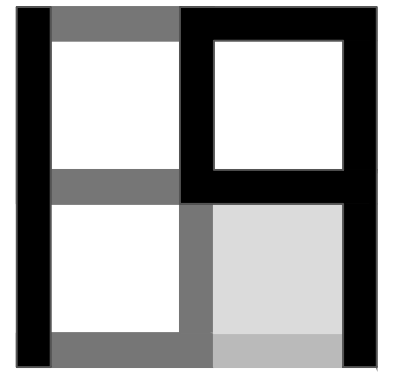

- GENERAL NOTES**
- 1-HR FIRE RATED ASSEMBLY BETWEEN GARAGE AND DWELLING, AND USABLE SPACE BELOW STAIR, SEE SHEET A2.01.
 - 1/2" GYPSUM BOARD ON GARAGE SIDE REQUIRED AT WALLS SEPARATING GARAGE AND DWELLING.
 - GARAGE CEILING REQUIRES 5/8" TYPE X GYPSUM BOARD, AND SUPPORTING STRUCTURE REQUIRES 1/2" GYPSUM BOARD.
 - 1-3/8" THICK MINIMUM SOLID CORE OR 20 MINUTE DOOR REQUIRED BETWEEN GARAGE AND DWELLING, SEE SHEET A9.01.
 - KITCHEN, BATHROOMS, LAUNDRY ROOM MUST BE VENTED MECHANICALLY PER SRC TABLE M1507.3.
 - NON COMBUSTIBLE SURFACE ON GARAGE FLOORS (SRC R309.1).
 - RESIDENTIAL ELEVATORS #950 HYD HP1 S 15 RH RAIL. PRIVATE RESIDENCE ELEVATORS SHALL COMPLY WITH ASME A17.1 AS REQUIRED BY IRC SECTION R323.1. ELEVATOR TO BE INSTALLED BY A LICENSED ELEVATOR CONTRACTOR AND SHALL HAVE YEARLY SAFETY INSPECTIONS AS REQUIRED BY WASHINGTON STATE DEPT. OF LABOR AND INDUSTRIES.

CONSULTANT: _____

PROFESSIONAL SEAL: _____



PROJECT: _____

a project for:
Barcelo homes
PO BOX 1733 AUBURN, WA 98071
Phone: (206) 724-1072

EAST MERCER RESIDENCE

4634 EAST MERCER WAY
MERCER ISLAND, WA 98040

SHEET ISSUE: _____

| | |
|------------|--------------------|
| 6/24/2015 | PERMIT SUBMITTAL |
| 8/29/2016 | PERMIT APPROVED |
| 6/05/2017 | REVISION TO PERMIT |
| 05/08/2018 | REVISION TO PERMIT |

MUNICIPALITY REVIEW: _____

PROJECT # MERCER ISLAND 15 - 015

SHEET TITLE: _____

LEVEL 1 FLOOR PLAN

PROJECT NO.: 20140904

DATE ISSUED: 05/08/2018

SHEET NUMBER: _____

A2.01

Exhibit 5

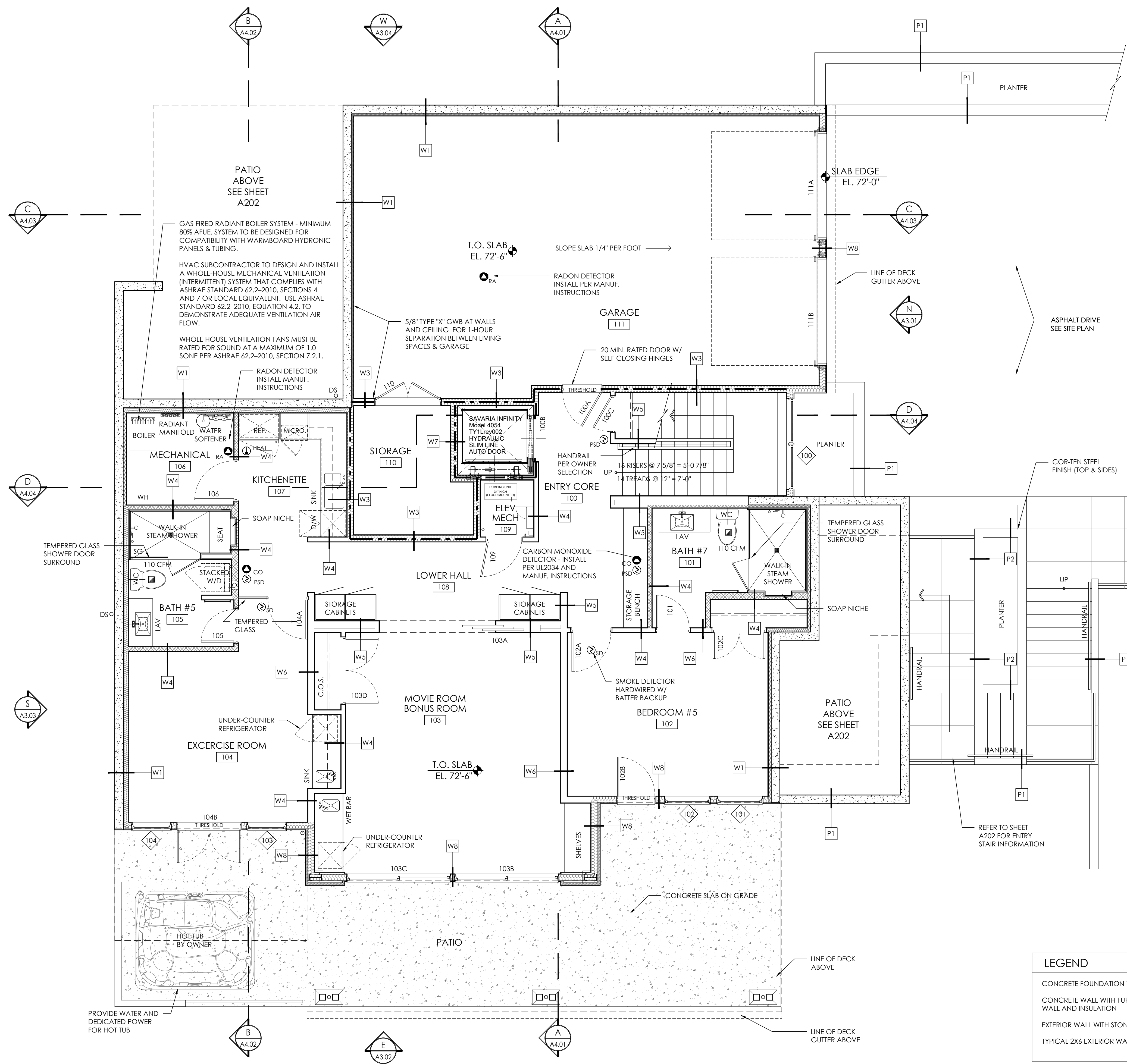

WALL TYPES

- W1** EXTERIOR BELOW GRADE CONCRETE WALLS
PROTECTION BOARD OVER
DRAINAGE MATT / DAMPROOFING OVER
REINFORCED CONCRETE WALL (PER STRUCTURAL)
WITH 1" AIR SPACE
WITH R-21 SPRAY FOAM INSULATION MIN. (OR EQUAL)
WITH 2x4 / 2x6 FRAMING @ 16" O.C. (PER STRUCTURAL)
WITH 1/2" GYPSUM WALL BOARD
WITH VAPOR BARRIER PVA PRIMER
FINISH PER INTERIORS
- W2** INTERIOR CONCRETE WALLS
FINISH PER INTERIORS OVER
1/2" GYPSUM WALL BOARD OVER DRAINAGE MATT / DAMPROOFING
OVER 2x4 / 2x6 FRAMING @ 16" O.C. (PER STRUCTURAL) OVER
1" AIR SPACE OVER
REINFORCED CONCRETE WALL (PER STRUCTURAL)
WITH 1" AIR SPACE
WITH 2x4 / 2x6 FRAMING @ 16" O.C. (PER STRUCTURAL)
WITH 1/2" GYPSUM WALL BOARD
WITH VAPOR BARRIER PVA PRIMER
FINISH PER INTERIORS
- W3** INTERIOR GARAGE TO HEATED SPACE 2x6 WALL ASSEMBLY
(1 HOUR RATED)
FINISH COAT EACH SIDE OVER
VAPOR BARRIER PVC PRIMER EACH SIDE OVER
5/8" GYPSUM WALLBOARD EACH SIDE (TYPE-X AT GARAGE) OVER
2x6 STUDS @ 16" O.C. OR AS NOTED.
R 21 FIBERGLASS INSULATION
- W4** INTERIOR FRAMED WALL ASSEMBLY (2x4)
FINISH COAT EACH SIDE OVER
VAPOR BARRIER PVC PRIMER EACH SIDE OVER
1/2" GYPSUM WALLBOARD EACH SIDE (SUBSTITUTE GREEN BOARD @
ALL BATHROOM WALLS) OVER
2X4 FRAMING
SOUND ATTENUATION INSULATION AT ALL BEDROOMS, BATHROOMS,
MECHANICAL ROOMS, AND AS NOTED ON PLAN.
- W5** INTERIOR FRAMED WALL ASSEMBLY - DOUBLE STUD (2x4)
FINISH COAT EACH SIDE OVER
VAPOR BARRIER PVC PRIMER EACH SIDE OVER
1/2" GYPSUM WALLBOARD EACH SIDE OVER
DOUBLE ROW 2X4 FRAMING @ 16" O.C. (U.N.O.) OR
SINGLE ROW 2x4 + SINGLE ROW 2x6 @ 16" O.C. (SEE PLAN)
SOUND ATTENUATION INSULATION AT ALL BEDROOMS, BATHROOMS,
MECHANICAL ROOMS, AND AS NOTED ON PLAN.
- W6** INTERIOR FRAMED WALL ASSEMBLY (2x6)
FINISH COAT EACH SIDE OVER
VAPOR BARRIER PVC PRIMER EACH SIDE OVER
1/2" GYPSUM WALLBOARD EACH SIDE (SUBSTITUTE GREEN BOARD @
ALL BATHROOM WALLS) OVER
2X6 FRAMING
SOUND ATTENUATION INSULATION AT ALL BEDROOMS, BATHROOMS,
MECHANICAL ROOMS, AND AS NOTED.
- W7** INTERIOR 1 HR FIRE RATED WALL ASSEMBLY
FINISH COAT EACH SIDE OVER
VAPOR BARRIER PVC PRIMER EACH SIDE OVER
5/8" GYPSUM TYPE 'X' WALLBOARD EACH SIDE OVER
2X4 FRAMING @ 16" O.C.
SOUND ATTENUATION INSULATION AT ALL BEDROOMS, BATHROOMS,
MECHANICAL ROOMS, AND AS NOTED.
- W8** EXTERIOR 2x6 WALL ASSEMBLY
EXTERIOR FINISH PER ELEVATIONS OVER
RAINSCREEN DRAINAGE SYSTEM
W/ CLIP SYSTEM AS INDICATED OVER
WEATHER RESISTIVE BARRIER OVER
PLYWOOD SHEATHING PER STRUCTURAL OVER
2x6 STUDS @ 16" O.C.
WITH R-21 INSULATION (MIN)
WITH 1/2" GYPSUM WALL BOARD
WITH VAPOR BARRIER PVA PRIMER
FINISH PER INTERIORS

LEGEND

| | |
|---|----------------------------|
| CONCRETE FOUNDATION WALL | TYPICAL 2X4 INTERIOR WALL |
| CONCRETE WALL WITH FURRED WALL AND INSULATION | WALL WITH SOUND INSULATION |
| EXTERIOR WALL WITH STONE | 1-HR FIRE RATED WALL |
| TYPICAL 2X6 EXTERIOR WALL | |

A1 LEVEL 1 - FLOOR PLAN
SCALE: 1/4" = 1'-0"
(1,716 SF LIVING + 898 SF GARAGE)

File: A201 Level 1 Floor Plan.dwg / Sheet: A201 / Plot Date: May 6, 2018

CONSULTANT: _____

PROFESSIONAL SEAL: _____

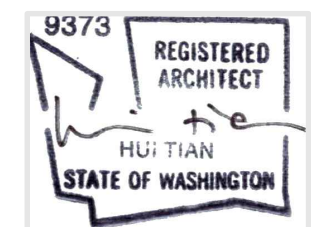

PROJECT: _____

a project for:

 PO BOX 1733 AUBURN, WA 98071
 Phone: (206) 724-1072

EAST MERCER RESIDENCE

4634 EAST MERCER WAY
 MERCER ISLAND, WA 98040

SHEET ISSUE: _____

| | |
|-----------------|--------------------|
| 6/24/2015 | PERMIT SUBMITTAL |
| 8/29/2016 | PERMIT APPROVED |
| 1 6/05/2017 | REVISION TO PERMIT |
| 2 05/08/2018 | REVISION TO PERMIT |

| MARK | DATE | DESCRIPTION |
|------|------|-------------|
| | | |

MUNICIPALITY REVIEW: _____

PROJECT # MERCER ISLAND 15 - 015

SHEET TITLE: _____

LEVEL 1
 DIMENSION PLAN

PROJECT NO.: 20140904

DATE ISSUED: 05/08/2018

SHEET NUMBER: _____

A2.01.1
 Exhibit 5

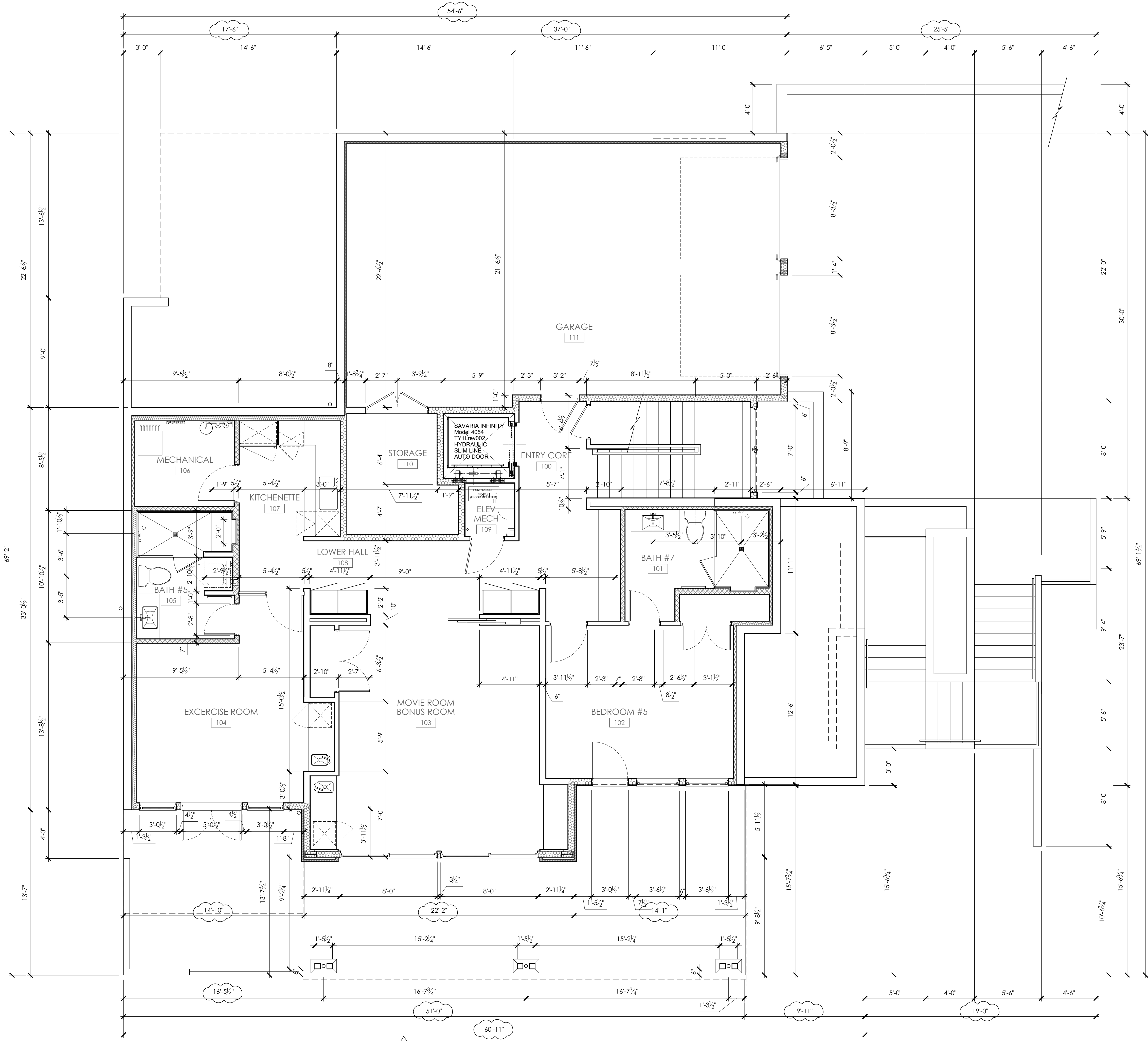

A1 LEVEL 1 - DIMENSION PLAN
 SCALE: 1/4" = 1'-0"

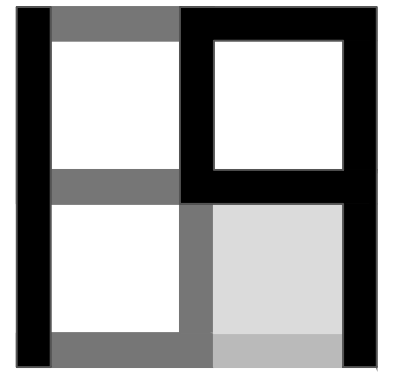

GENERAL NOTES

- 1-HR FIRE RATED ASSEMBLY BETWEEN GARAGE AND DWELLING, AND USABLE SPACE BELOW STAIR, SEE SHEET A2.01.
- 1/2" GYPSUM BOARD ON GARAGE SIDE REQUIRED AT WALLS SEPARATING GARAGE AND DWELLING.
- GARAGE CEILING REQUIRES 5/8" TYPE X GYPSUM BOARD, AND SUPPORTING STRUCTURE REQUIRES 1/2" GYPSUM BOARD.
- 1-3/8" THICK MINIMUM SOLID CORE OR 20 MINUTE DOOR REQUIRED BETWEEN GARAGE AND DWELLING. SEE SHEET A9.01.
- KITCHEN, BATHROOMS, LAUNDRY ROOM MUST BE VENTED MECHANICALLY PER SRC TABLE M1507.3.
- NON COMBUSTIBLE SURFACE ON GARAGE FLOORS (SRC R309.1).
- RESIDENTIAL ELEVATORS #950 HYD HP1 S 15 RH RAIL. PRIVATE RESIDENCE ELEVATORS SHALL COMPLY WITH ASME A17.1 AS REQUIRED BY IRC SECTION R323.1. ELEVATOR TO BE INSTALLED BY A LICENSED ELEVATOR CONTRACTOR AND SHALL HAVE YEARLY SAFETY INSPECTIONS AS REQUIRED BY WASHINGTON STATE DEPT. OF LABOR AND INDUSTRIES.

WALL TYPES

- W1** EXTERIOR BELOW GRADE CONCRETE WALLS
PROTECTION BOARD OVER
DRAINAGE MATT / DAMPROOFING OVER
REINFORCED CONCRETE WALL (PER STRUCTURAL)
WITH 1" AIR SPACE
WITH R-21 SPRAY FOAM INSULATION MIN. (OR EQUAL)
WITH 2x4 / 2x6 FRAMING @ 16" O.C. (PER STRUCTURAL)
WITH 1/2" GYPSUM WALL BOARD
WITH VAPOR BARRIER PVA PRIMER
FINISH PER INTERIORS
- W2** INTERIOR CONCRETE WALLS
FINISH PER INTERIORS OVER
1/2" GYPSUM WALL BOARD OVER DRAINAGE MATT / DAMPROOFING
OVER 2x4 / 2x6 FRAMING @ 16" O.C. (PER STRUCTURAL) OVER
1" AIR SPACE OVER
REINFORCED CONCRETE WALL (PER STRUCTURAL)
WITH 1" AIR SPACE
WITH 2x4 / 2x6 FRAMING @ 16" O.C. (PER STRUCTURAL)
WITH 1/2" GYPSUM WALL BOARD
FINISH PER INTERIORS
- W3** INTERIOR GARAGE TO HEATED SPACE 2x6 WALL ASSEMBLY
(1 HOUR RATED)
FINISH COAT EACH SIDE OVER
VAPOR BARRIER PVC PRIMER EACH SIDE OVER
5/8" GYPSUM WALLBOARD EACH SIDE (TYPE-X AT GARAGE) OVER
2x6 STUDS @ 16" O.C. OR AS NOTED.
R 21 FIBERGLASS INSULATION
- W4** INTERIOR FRAMED WALL ASSEMBLY (2x4)
FINISH COAT EACH SIDE OVER
VAPOR BARRIER PVC PRIMER EACH SIDE OVER
1/2" GYPSUM WALLBOARD EACH SIDE (SUBSTITUTE GREEN BOARD @
ALL BATHROOM WALLS) OVER
2X4 FRAMING
SOUND ATTENUATION INSULATION AT ALL BEDROOMS, BATHROOMS,
MECHANICAL ROOMS, AND AS NOTED ON PLAN.
- W5** INTERIOR FRAMED WALL ASSEMBLY - DOUBLE STUD (2x4)
FINISH COAT EACH SIDE OVER
VAPOR BARRIER PVC PRIMER EACH SIDE OVER
1/2" GYPSUM WALLBOARD EACH SIDE OVER
DOUBLE ROW 2X4 FRAMING @ 16" O.C. (U.N.O.) OR
SINGLE ROW 2x4 + SINGLE ROW 2x6 @ 16" O.C. (SEE PLAN)
SOUND ATTENUATION INSULATION AT ALL BEDROOMS, BATHROOMS,
MECHANICAL ROOMS, AND AS NOTED ON PLAN.
- W6** INTERIOR FRAMED WALL ASSEMBLY (2x6)
FINISH COAT EACH SIDE OVER
VAPOR BARRIER PVC PRIMER EACH SIDE OVER
1/2" GYPSUM WALLBOARD EACH SIDE (SUBSTITUTE GREEN BOARD @
ALL BATHROOM WALLS) OVER
2X6 FRAMING
SOUND ATTENUATION INSULATION AT ALL BEDROOMS, BATHROOMS,
MECHANICAL ROOMS, AND AS NOTED.
- W7** INTERIOR 1 HR FIRE RATED WALL ASSEMBLY
FINISH COAT EACH SIDE OVER
VAPOR BARRIER PVC PRIMER EACH SIDE OVER
5/8" GYPSUM TYPE 'X' WALLBOARD EACH SIDE OVER
2X4 FRAMING @ 16" O.C.
SOUND ATTENUATION INSULATION AT ALL BEDROOMS, BATHROOMS,
MECHANICAL ROOMS, AND AS NOTED.
- W8** EXTERIOR 2x6 WALL ASSEMBLY
EXTERIOR FINISH PER ELEVATIONS OVER
RAINSREEN DRAINAGE SYSTEM
W/ CLIP SYSTEM AS INDICATED OVER
WEATHER RESISTIVE BARRIER OVER
PLYWOOD SHEATHING PER STRUCTURAL OVER
2x6 STUDS @ 16" O.C.
WITH R-21 INSULATION (MIN)
WITH 1/2" GYPSUM WALL BOARD
WITH VAPOR BARRIER PVA PRIMER
FINISH PER INTERIORS

LEGEND

| | |
|---|----------------------------|
| CONCRETE FOUNDATION WALL | TYPICAL 2X4 INTERIOR WALL |
| CONCRETE WALL WITH FURRED WALL AND INSULATION | WALL WITH SOUND INSULATION |
| EXTERIOR WALL WITH STONE | 1-HR FIRE RATED WALL |
| TYPICAL 2X6 EXTERIOR WALL | |

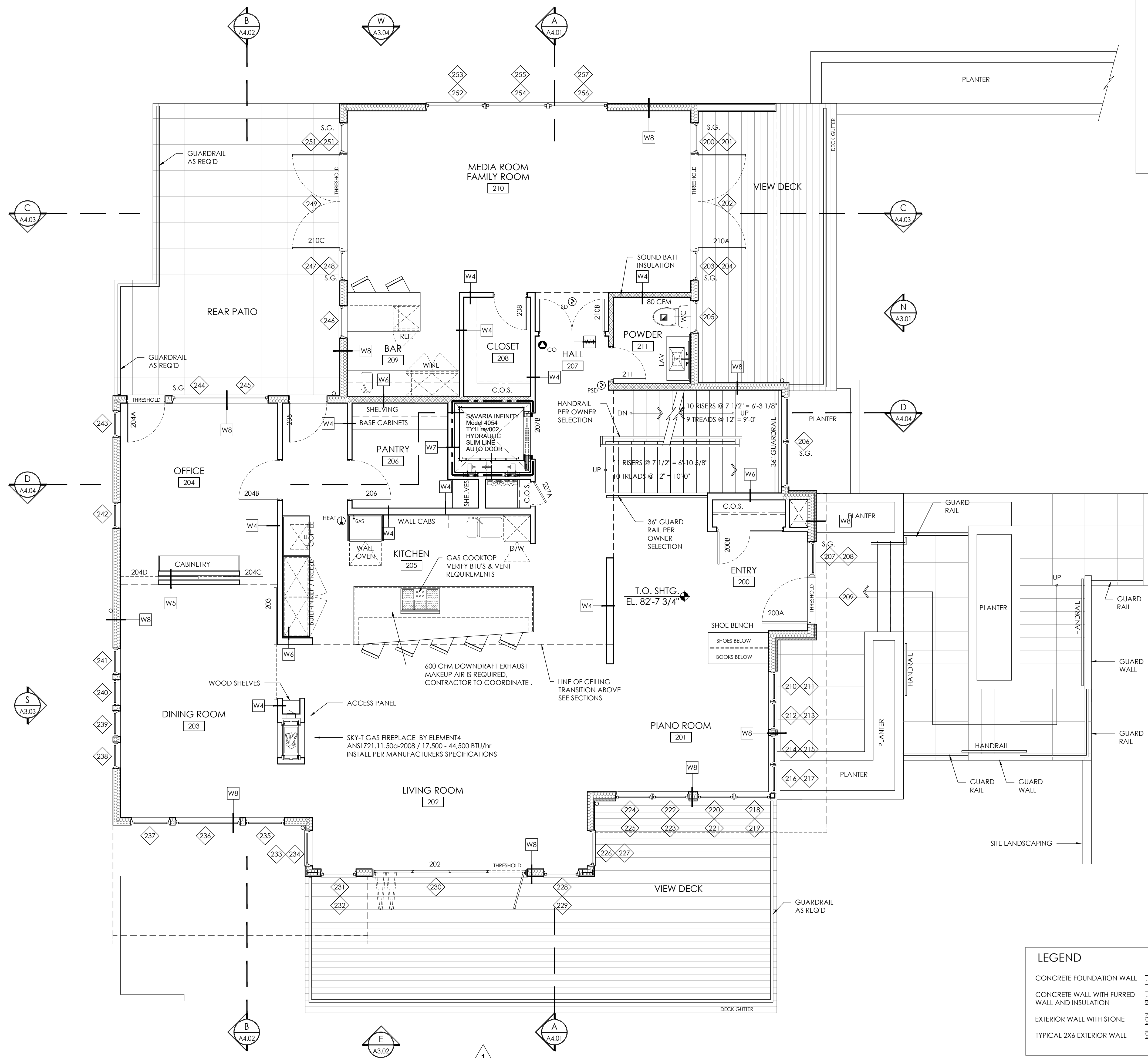

A2 LEVEL 2 - FLOOR PLAN (2,408 SF LIVING)
SCALE: 1/4" = 1'-0"

CONSULTANT: _____

PROFESSIONAL SEAL: _____



PROJECT: _____

a project for:
Barcelo homes
PO BOX 1733 AUBURN, WA 98071
Phone: (206) 724-1072

EAST MERCER RESIDENCE

4634 EAST MERCER WAY
MERCER ISLAND, WA 98040

SHEET ISSUE: _____

| MARK | DATE | DESCRIPTION |
|------|------------|--------------------|
| | 6/24/2015 | PERMIT SUBMITTAL |
| | 8/29/2016 | PERMIT APPROVED |
| 1 | 6/05/2017 | REVISION TO PERMIT |
| 2 | 05/08/2018 | REVISION TO PERMIT |

MUNICIPALITY REVIEW: _____

PROJECT # MERCER ISLAND 15 - 015

SHEET TITLE: _____

LEVEL 2
FLOOR PLAN

PROJECT NO.: 20140904

DATE ISSUED: 05/08/2018

SHEET NUMBER: _____

A2.02
Exhibit 5

CONSULTANT: _____

PROFESSIONAL SEAL: _____

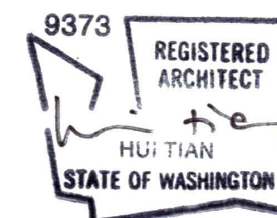

PROJECT: _____

a project for:

 PO BOX 1733 AUBURN, WA 98071
 Phone: (206) 724-1072

EAST MERCER RESIDENCE

4634 EAST MERCER WAY
 MERCER ISLAND, WA 98040

SHEET ISSUE: _____

| MARK | DATE | DESCRIPTION |
|------|------------|--------------------|
| | 6/24/2015 | PERMIT SUBMITTAL |
| | 8/29/2016 | PERMIT APPROVED |
| 1 | 6/05/2017 | REVISION TO PERMIT |
| 2 | 05/08/2018 | REVISION TO PERMIT |

MARK DATE DESCRIPTION

MUNICIPALITY REVIEW: _____

PROJECT # MERCER ISLAND 15 - 015

SHEET TITLE: _____

LEVEL 2
 DIMENSION PLAN

PROJECT NO.: 20140904
 DATE ISSUED: 05/08/2018

SHEET NUMBER: **A2.02.1**
 Exhibit 5

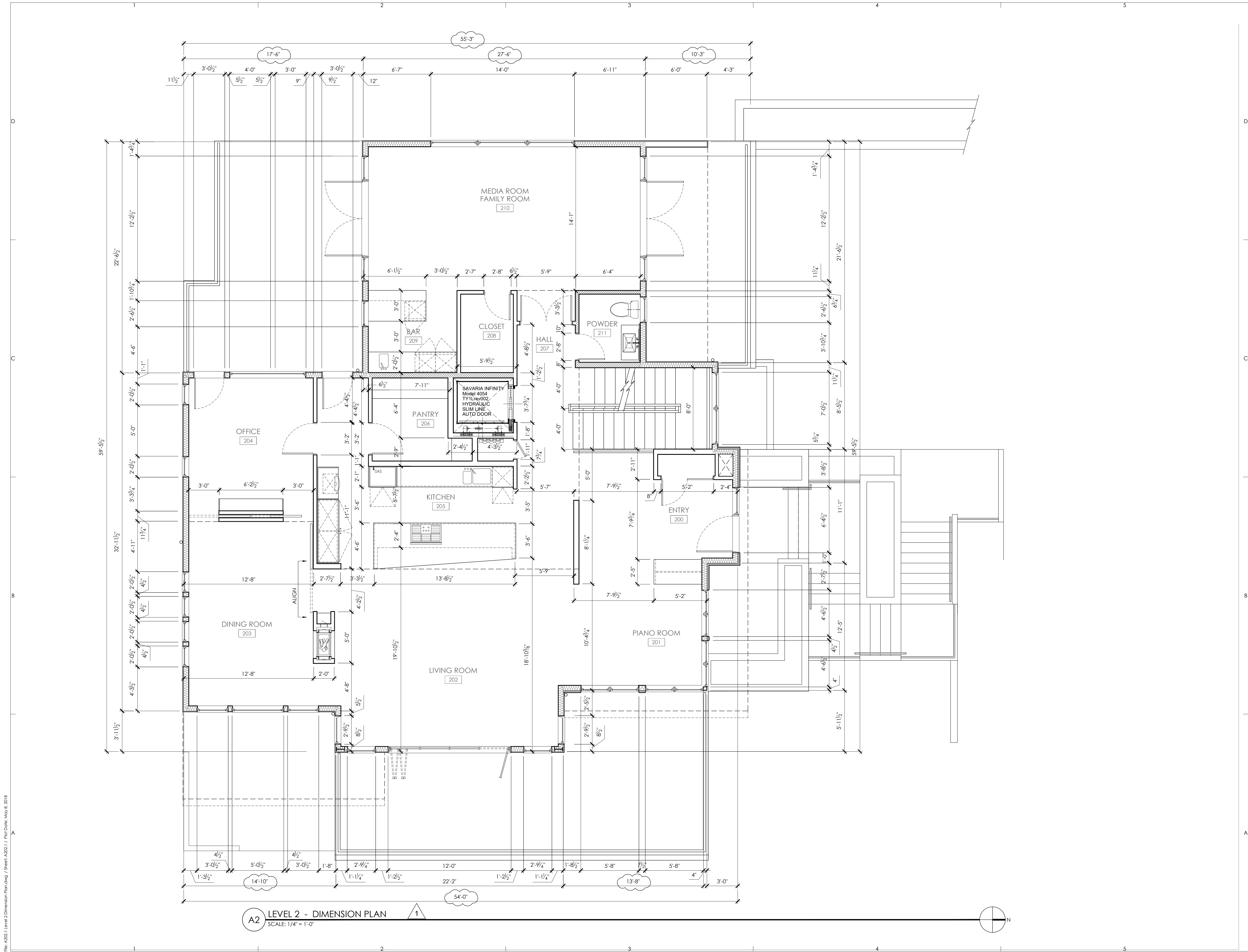

A2 LEVEL 2 - DIMENSION PLAN
 SCALE: 1/4" = 1'-0"

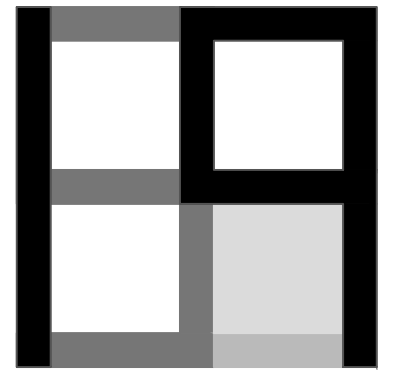

GENERAL NOTES

- 1-HR FIRE RATED ASSEMBLY BETWEEN GARAGE AND DWELLING, AND USABLE SPACE BELOW STAIR, SEE SHEET A2.01.
- 1/2" GYPSUM BOARD ON GARAGE SIDE REQUIRED AT WALLS SEPARATING GARAGE AND DWELLING.
- GARAGE CEILINGS REQUIRES 5/8" TYPE X GYPSUM BOARD, AND SUPPORTING STRUCTURE REQUIRES 1/2" GYPSUM BOARD.
- 1-3/8" THICK MINIMUM SOLID CORE OR 20 MINUTE DOOR REQUIRED BETWEEN GARAGE AND DWELLING, SEE SHEET A9.01.
- KITCHEN, BATHROOMS, LAUNDRY ROOM MUST BE VENTED MECHANICALLY PER SRC TABLE M1507.3.
- NON COMBUSTIBLE SURFACE ON GARAGE FLOORS (SRC R309.1).
- RESIDENTIAL ELEVATORS #950 HYD HP1 S 15 RH RAIL. PRIVATE RESIDENCE ELEVATORS SHALL COMPLY WITH ASME A17.1 AS REQUIRED BY IRC SECTION R323.1. ELEVATOR TO BE INSTALLED BY A LICENSED ELEVATOR CONTRACTOR AND SHALL HAVE YEARLY SAFETY INSPECTIONS AS REQUIRED BY WASHINGTON STATE DEPT. OF LABOR AND INDUSTRIES.

WALL TYPES

- W1** EXTERIOR ABOVE GRADE CONCRETE WALLS
PROTECTION BOARD OVER
DRAINAGE MATT / DAMPROOFING OVER
REINFORCED CONCRETE WALL (PER STRUCTURAL)
WITH 1" AIR SPACE
WITH R-21 SPREAY FOAM INSULATION MIN. (OR EQUAL)
WITH 2x4 / 2x6 FRAMING @ 16" O.C. (PER STRUCTURAL)
WITH 1/2" GYPSUM WALL BOARD
WITH VAPOR BARRIER PVA PRIMER
FINISH PER INTERIORS
- W2** INTERIOR CONCRETE WALLS
FINISH PER INTERIORS OVER
1/2" GYPSUM WALL BOARD OVER DRAINAGE MATT / DAMPROOFING
OVER 2x4 / 2x6 FRAMING @ 16" O.C. (PER STRUCTURAL) OVER
1" AIR SPACE OVER
REINFORCED CONCRETE WALL (PER STRUCTURAL)
WITH 1" AIR SPACE
WITH 2x4 / 2x6 FRAMING @ 16" O.C. (PER STRUCTURAL)
WITH 1/2" GYPSUM WALL BOARD
FINISH PER INTERIORS
- W3** INTERIOR GARAGE TO HEATED SPACE 2x6 WALL ASSEMBLY
(1 HOUR RATED)
FINISH COAT EACH SIDE OVER
VAPOR BARRIER PVC PRIMER EACH SIDE OVER
5/8" GYPSUM WALLBOARD EACH SIDE (TYPE-X AT GARAGE) OVER
2X6 STUDS @ 16" O.C. OR AS NOTED.
R-21 FIBERGLASS INSULATION
- W4** INTERIOR FRAMED WALL ASSEMBLY (2x4)
FINISH COAT EACH SIDE OVER
VAPOR BARRIER PVC PRIMER EACH SIDE OVER
1/2" GYPSUM WALLBOARD EACH SIDE (SUBSTITUTE GREEN BOARD @
ALL BATHROOM WALLS) OVER
2X4 FRAMING
SOUND ATTENUATION INSULATION AT ALL BEDROOMS, BATHROOMS,
MECHANICAL ROOMS, AND AS NOTED ON PLAN.
- W5** INTERIOR FRAMED WALL ASSEMBLY - DOUBLE STUD (2x4)
FINISH COAT EACH SIDE OVER
VAPOR BARRIER PVC PRIMER EACH SIDE OVER
1/2" GYPSUM WALLBOARD EACH SIDE OVER
DOUBLE ROW 2X4 FRAMING @ 16" O.C. (U.N.O.) OR
SINGLE ROW 2x4 + SINGLE ROW 2x6 @ 16" O.C. (SEE PLAN)
SOUND ATTENUATION INSULATION AT ALL BEDROOMS, BATHROOMS,
MECHANICAL ROOMS, AND AS NOTED ON PLAN.
- W6** INTERIOR FRAMED WALL ASSEMBLY (2x6)
FINISH COAT EACH SIDE OVER
VAPOR BARRIER PVC PRIMER EACH SIDE OVER
1/2" GYPSUM WALLBOARD EACH SIDE (SUBSTITUTE GREEN BOARD @
ALL BATHROOM WALLS) OVER
2X6 FRAMING
SOUND ATTENUATION INSULATION AT ALL BEDROOMS, BATHROOMS,
MECHANICAL ROOMS, AND AS NOTED.
- W7** INTERIOR 1 HR FIRE RATED WALL ASSEMBLY
FINISH COAT EACH SIDE OVER
VAPOR BARRIER PVC PRIMER EACH SIDE OVER
5/8" GYPSUM TYPE 'X' WALLBOARD EACH SIDE OVER
2X4 FRAMING @ 16" O.C.
SOUND ATTENUATION INSULATION AT ALL BEDROOMS, BATHROOMS,
MECHANICAL ROOMS, AND AS NOTED.
- W8** EXTERIOR 2x6 WALL ASSEMBLY
EXTERIOR FINISH PER ELEVATIONS OVER
RAINSREEN DRAINAGE SYSTEM
W/ CLIP SYSTEM AS INDICATED OVER
WEATHER RESISTIVE BARRIER OVER
PLYWOOD SHEATHING PER STRUCTURAL OVER
2x6 STUDS @ 16" O.C.
WITH R-21 INSULATION (MIN)
WITH 1/2" GYPSUM WALL BOARD
WITH VAPOR BARRIER PVA PRIMER
FINISH PER INTERIORS

LEGEND

| | |
|---|----------------------------|
| CONCRETE FOUNDATION WALL | TYPICAL 2X4 INTERIOR WALL |
| CONCRETE WALL WITH FURRED WALL AND INSULATION | WALL WITH SOUND INSULATION |
| EXTERIOR WALL WITH STONE | 1-HR FIRE RATED WALL |
| TYPICAL 2X6 EXTERIOR WALL | |

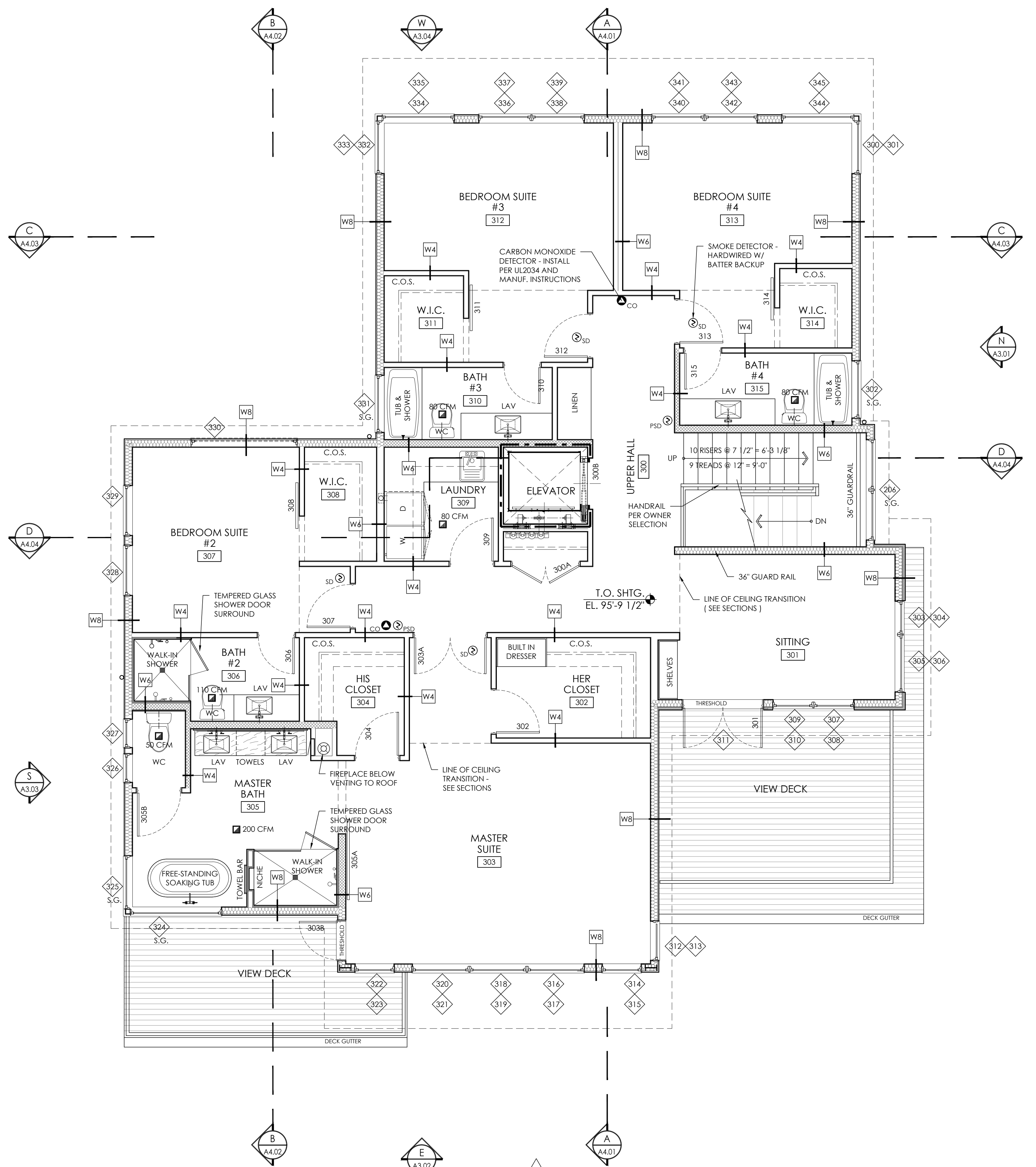

A3 LEVEL 3 - FLOOR PLAN
SCALE: 1/4" = 1'-0"
(2,364 SF LIVING)

CONSULTANT: _____

PROFESSIONAL SEAL: _____



PROJECT: _____

a project for:
Barcelo homes
PO BOX 1733 AUBURN, WA 98071
Phone: (206) 724-1072

EAST MERCER RESIDENCE

4634 EAST MERCER WAY
MERCER ISLAND, WA 98040

SHEET ISSUE:

| | |
|------------|--------------------|
| 6/24/2015 | PERMIT SUBMITTAL |
| 8/29/2016 | PERMIT APPROVED |
| 6/05/2017 | REVISION TO PERMIT |
| 05/08/2018 | REVISION TO PERMIT |

MARK DATE DESCRIPTION

MUNICIPALITY REVIEW:

PROJECT # MERCER ISLAND 15 - 015

SHEET TITLE:

LEVEL 3
FLOOR PLAN

PROJECT NO.: 20140904
DATE ISSUED: 05/08/2018

SHEET NUMBER: **A2.03**

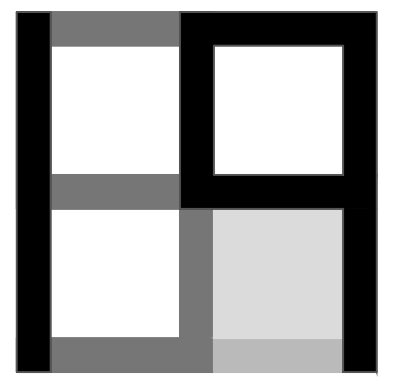

CONSULTANT:

PROFESSIONAL SEAL:

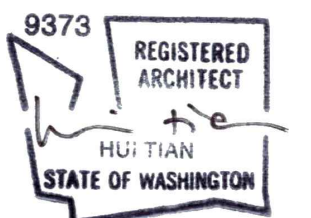

PROJECT:

a project for:
Barcelo homes
PO BOX 1733 AUBURN, WA 98071
Phone: (206) 724-1072

EAST MERCER RESIDENCE

4634 EAST MERCER WAY
MERCER ISLAND, WA 98040

SHEET ISSUE:

| | |
|--------------|--------------------|
| 6/24/2015 | PERMIT SUBMITTAL |
| 8/29/2016 | PERMIT APPROVED |
| 1 6/05/2017 | REVISION TO PERMIT |
| 2 05/08/2018 | REVISION TO PERMIT |

MARK DATE DESCRIPTION

MUNICIPALITY REVIEW:

PROJECT # MERCER ISLAND 15 - 015

SHEET TITLE:

LEVEL 3
DIMENSION PLAN

PROJECT NO.: 20140904

DATE ISSUED: 05/08/2018

SHEET NUMBER:

A2.03.1
Exhibit 5

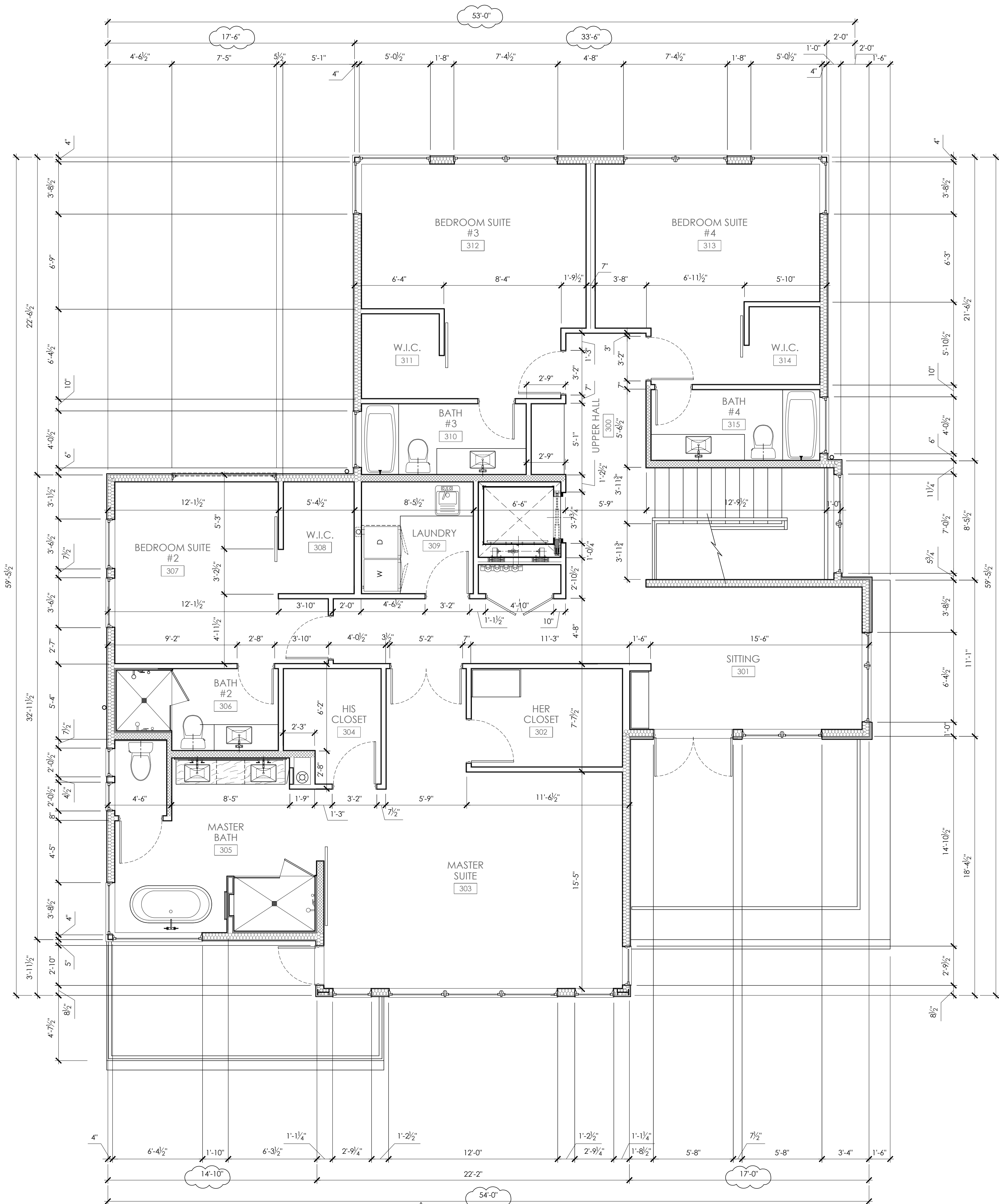

A3 LEVEL 3 - DIMENSION PLAN
SCALE: 1/4" = 1'-0"

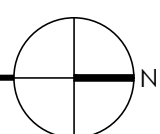

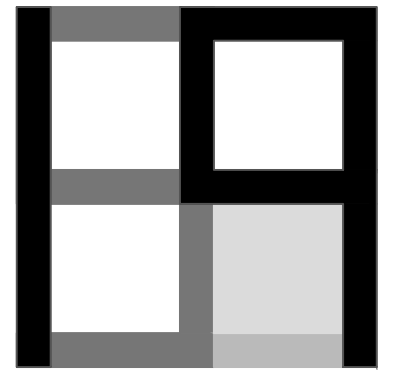

CONSULTANT:

PROFESSIONAL SEAL:

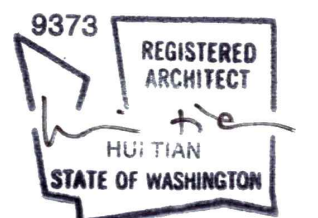

PROJECT:

a project for:
Barcelo homes
PO BOX 1733 AUBURN, WA 98071
Phone: (206) 724-1072

EAST MERCER RESIDENCE

4634 EAST MERCER WAY
MERCER ISLAND, WA 98040

SHEET ISSUE:

| | |
|------------|--------------------|
| 6/24/2015 | PERMIT SUBMITTAL |
| 8/29/2016 | PERMIT APPROVED |
| 6/05/2017 | REVISION TO PERMIT |
| 05/08/2018 | REVISION TO PERMIT |

MARK DATE DESCRIPTION

MUNICIPALITY REVIEW:

PROJECT # MERCER ISLAND 15 - 015

SHEET TITLE:

ROOF PLAN

PROJECT NO.: 20140904

DATE ISSUED: 05/08/2018

SHEET NUMBER:

A2.04
Exhibit 5

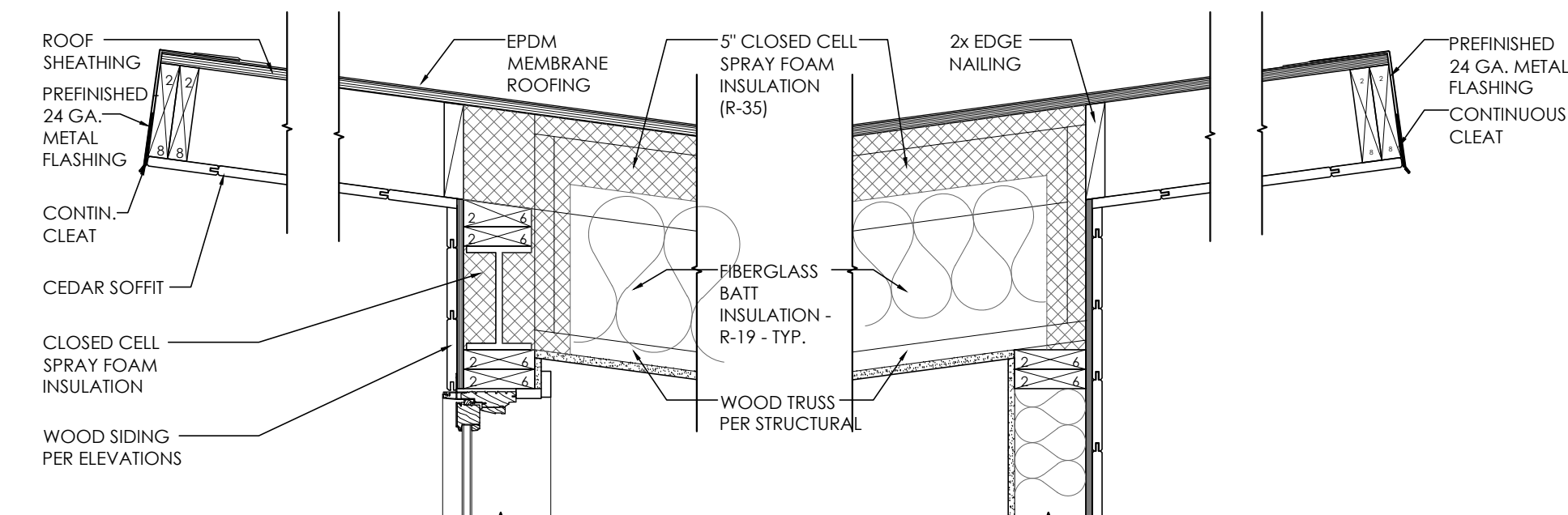

D1 ROOF EDGE DETAIL
SCALE: 1" = 1'-0"

D2 ROOF EDGE DETAIL
SCALE: 1" = 1'-0"

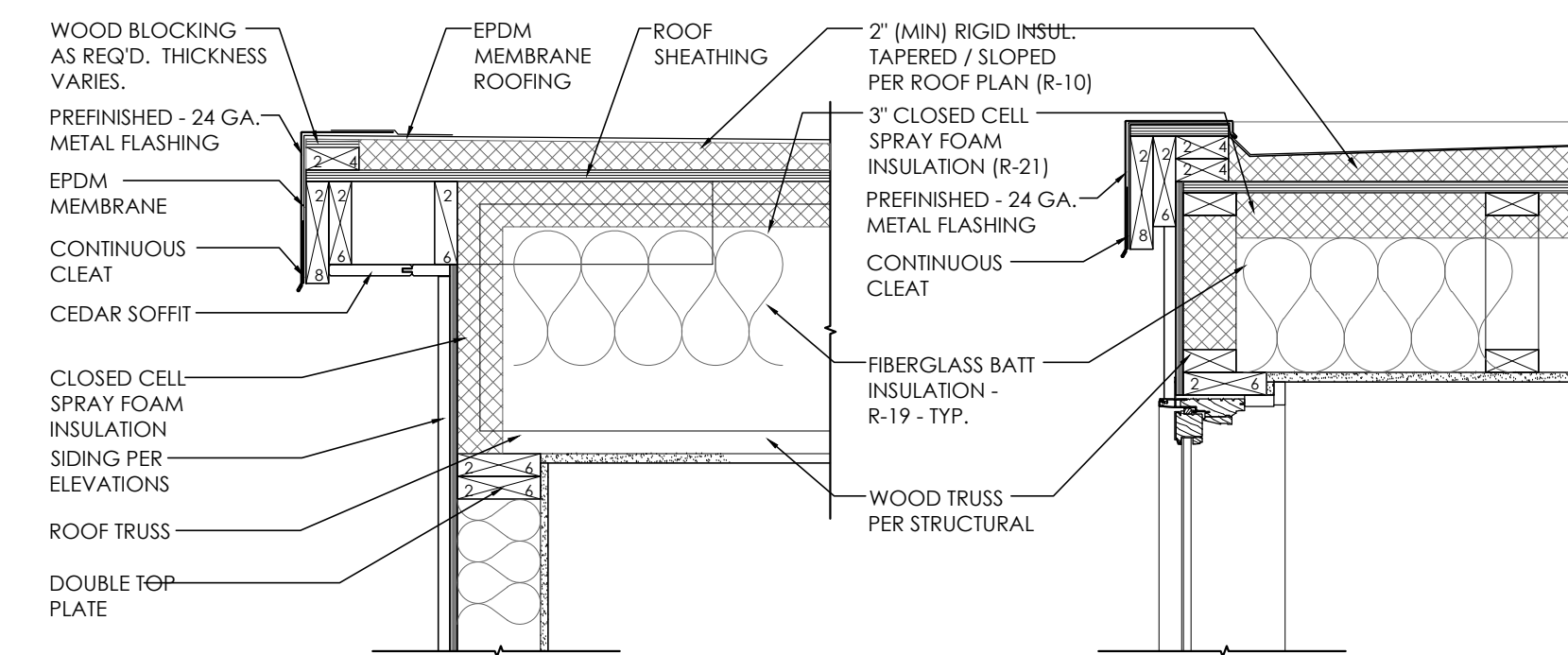

D3 ROOF EDGE DETAIL
SCALE: 1" = 1'-0"

D4 ROOF EDGE DETAIL
SCALE: 1" = 1'-0"

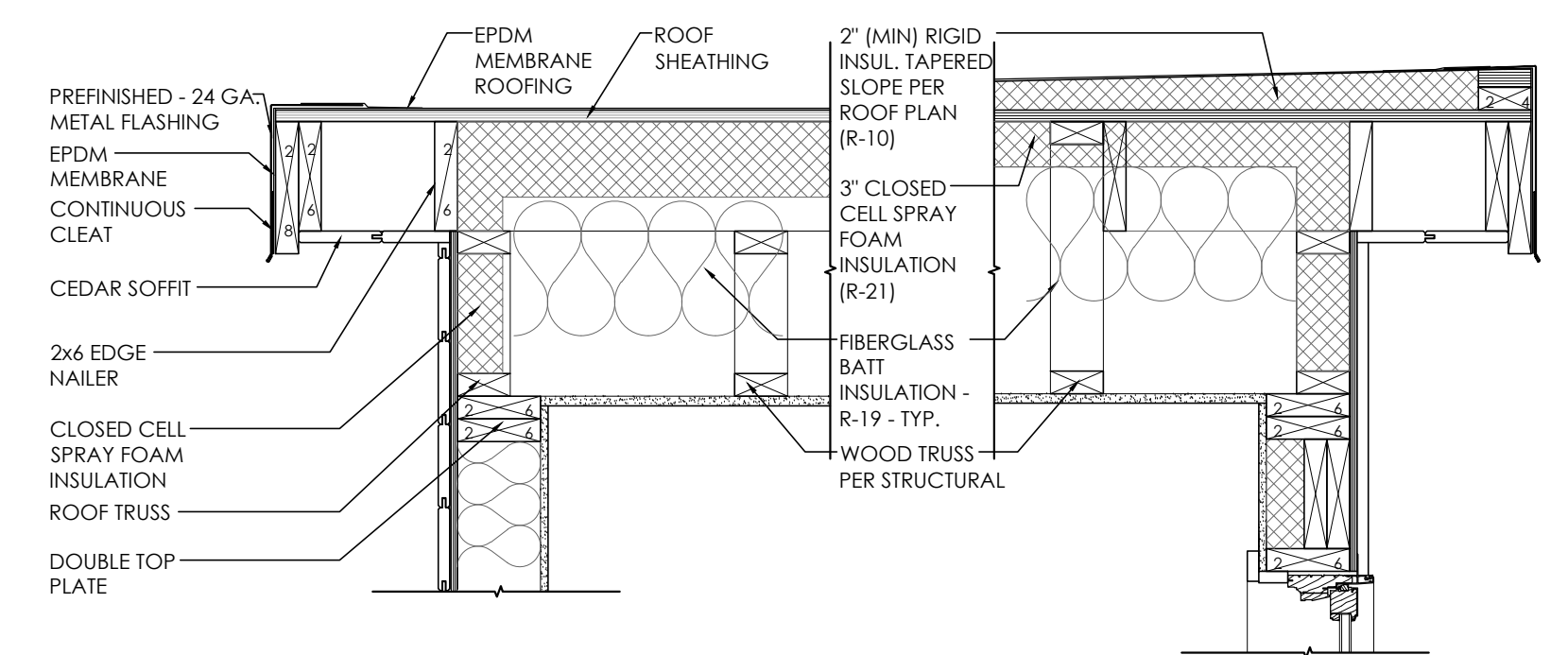

D5 ROOF EDGE DETAIL
SCALE: 1" = 1'-0"

D6 ROOF EDGE DETAIL
SCALE: 1" = 1'-0"

R1 FLAT ROOF / ROOF DECK ASSEMBLY
3-PLY EPDM SELF-ADHERING MEMBRANE
(SELF-ADHERING CAP SHT OVER
SELF-ADHERING BASE SHT OVER
MECHANICALLY-ADHERED BASE SHT) OVER
TAPERED INSULATION (MIN. R-10 AT LOW POINT) OVER
2 LAYERS OF 30 LB. ROOFING FELTS OVER
3/4 PLYWOOD SHEATHING PER STRUCT. OVER
3" (R-21) SPRAY APPLIED CLOSED CELL INSULATION
W/ VAPOR BARRIER TO UNDERSIDE OF DECKING
R-19 FIBERGLASS BATT INSULATION
(FOR TOTAL ASSEMBLY R-VALUE OF R-50)
ROOF TRUSSES/FRAMING PER STRUCT. W/
5/8 GYPSUM WALLBOARD &
FINISH PER OWNER SELECTION

R2 FLAT ROOF / ROOF DECK ASSEMBLY
3-PLY EPDM SELF-ADHERING MEMBRANE
(SELF-ADHERING CAP SHT OVER
SELF-ADHERING BASE SHT OVER
MECHANICALLY-ADHERED BASE SHT)
3/4 PLYWOOD SHEATHING PER STRUCT.
5" (R-35) SPRAY APPLIED CLOSED CELL INSULATION
W/ VAPOR BARRIER TO UNDERSIDE OF DECKING
R-19 FIBERGLASS BATT INSULATION
(FOR TOTAL ASSEMBLY R-VALUE OF R-54)
ROOF TRUSSES/FRAMING PER STRUCT. W/
5/8 GYPSUM WALLBOARD &
FINISH PER OWNER SELECTION

ROOF NOTES

- ALL WATERPROOFING SHOWN IS FOR DESIGN INTENT ONLY. ALL ELEMENTS OF THE WATERPROOFING SYSTEMS, DETAILS OF INSTALLATION, AND COORDINATION WITH ADJACENT MATERIALS AND FINISHES IS THE RESPONSIBILITY OF THE DESIGN-BUILD SUBCONTRACTOR FOR SUCH SYSTEM(S).
- UNVENTED ROOF ASSEMBLY PROPOSED. R-10 RIGID INSULATION ABOVE SHEATHING (WHERE APPLICABLE) WITH AIR-IMPERMEABLE SPRAY FOAM INSULATION BELOW.
- ALL ROOF PENETRATIONS, SUCH AS VENT STACKS, ETC., TO BE GROUPED TOGETHER AND LOCATED AS FAR AWAY FROM THE ROOF EDGE AS POSSIBLE.

WRITTEN DIMENSIONS ON THIS DRAWING SHALL HAVE PRECEDENCE OVER SCALED DIMENSIONS. CONTRACTOR SHALL VERIFY ALL DIMENSIONS, CONDITIONS, ETC. PERTAINING TO THE WORK BEFORE PROCEEDING. THE OWNER MUST BE NOTIFIED OF ANY VARIATIONS FROM THE DIMENSIONS AND/OR CONDITIONS SHOWN ON THESE DRAWINGS. ANY SUCH VARIATIONS SHALL BE RESOLVED BY THE OWNER PRIOR TO PROCEEDING WITH THE WORK, OR THE CONTRACTOR SHALL ACCEPT FULL RESPONSIBILITY FOR THE COST TO RECTIFY SAME.

NOTE:
T.O.W. TOP PLATE ELEVATIONS SHOWN FOR COMPLIANCE WITH HEIGHT ON DOWNSLOPE SIDE ABOVE EXISTING GRADE

A4 ROOF PLAN
SCALE: 1/4" = 1'-0"

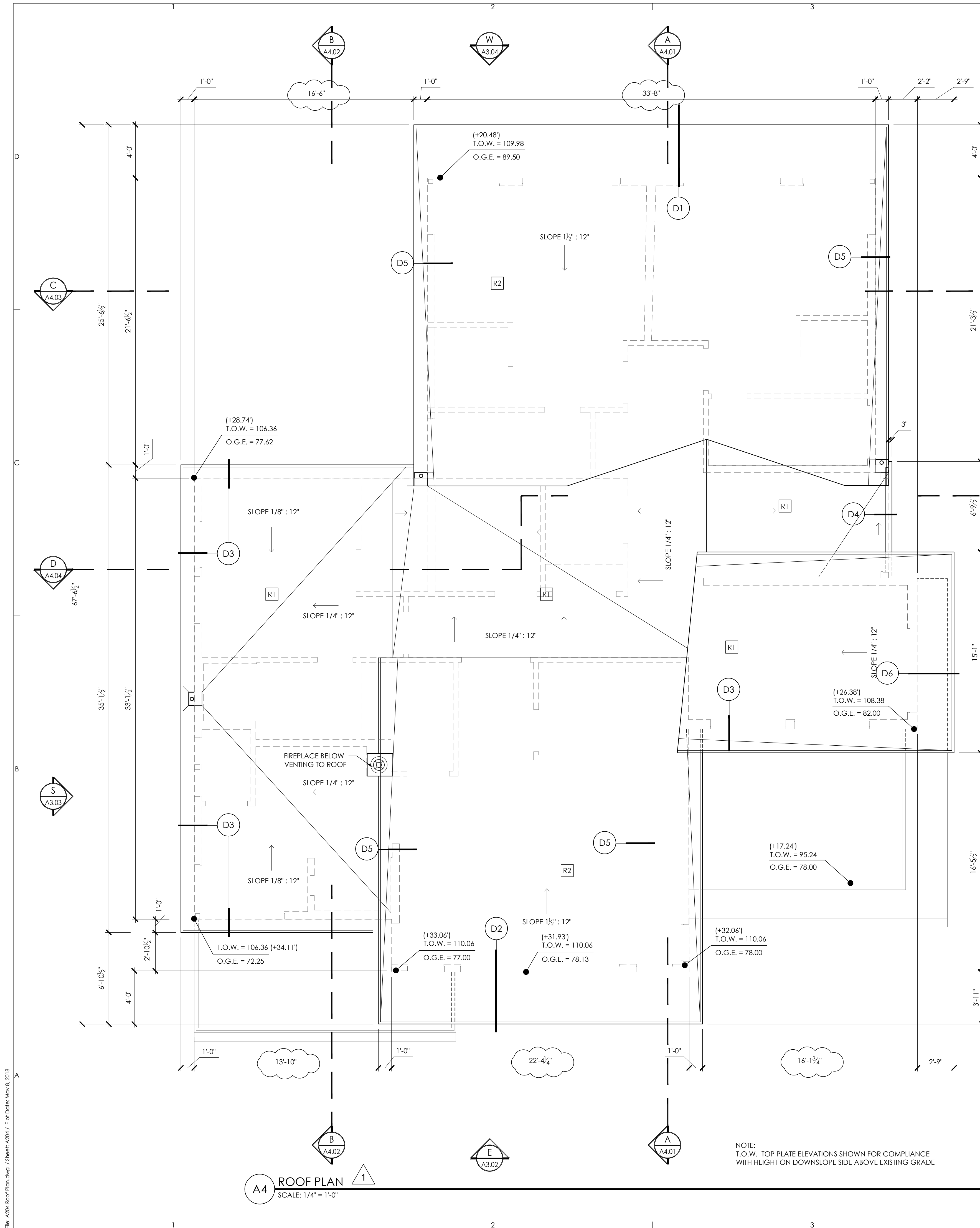

CONSULTANT: _____

PROFESSIONAL SEAL: _____

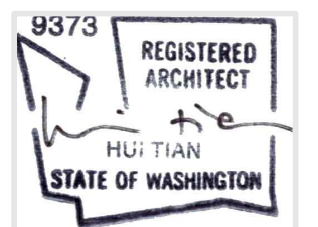

PROJECT: _____

a project for:

 PO BOX 1733 AUBURN, WA 98071
 Phone: (206) 724-1072

EAST MERCER RESIDENCE

4634 EAST MERCER WAY
 MERCER ISLAND, WA 98040

SHEET ISSUE:

| | |
|-----------------|--------------------|
| 6/24/2015 | PERMIT SUBMITTAL |
| 8/29/2016 | PERMIT APPROVED |
| 1 6/05/2017 | REVISION TO PERMIT |
| 2 05/08/2018 | REVISION TO PERMIT |

| MARK | DATE | DESCRIPTION |
|------|------|-------------|
| | | |

MUNICIPALITY REVIEW: _____

PROJECT # MERCER ISLAND 15 - 015

SHEET TITLE: _____

NORTH
 EXTERIOR ELEVATION

PROJECT NO.: 20140904

DATE ISSUED: 05/08/2018

SHEET NUMBER: _____

A3.01
 Exhibit 5

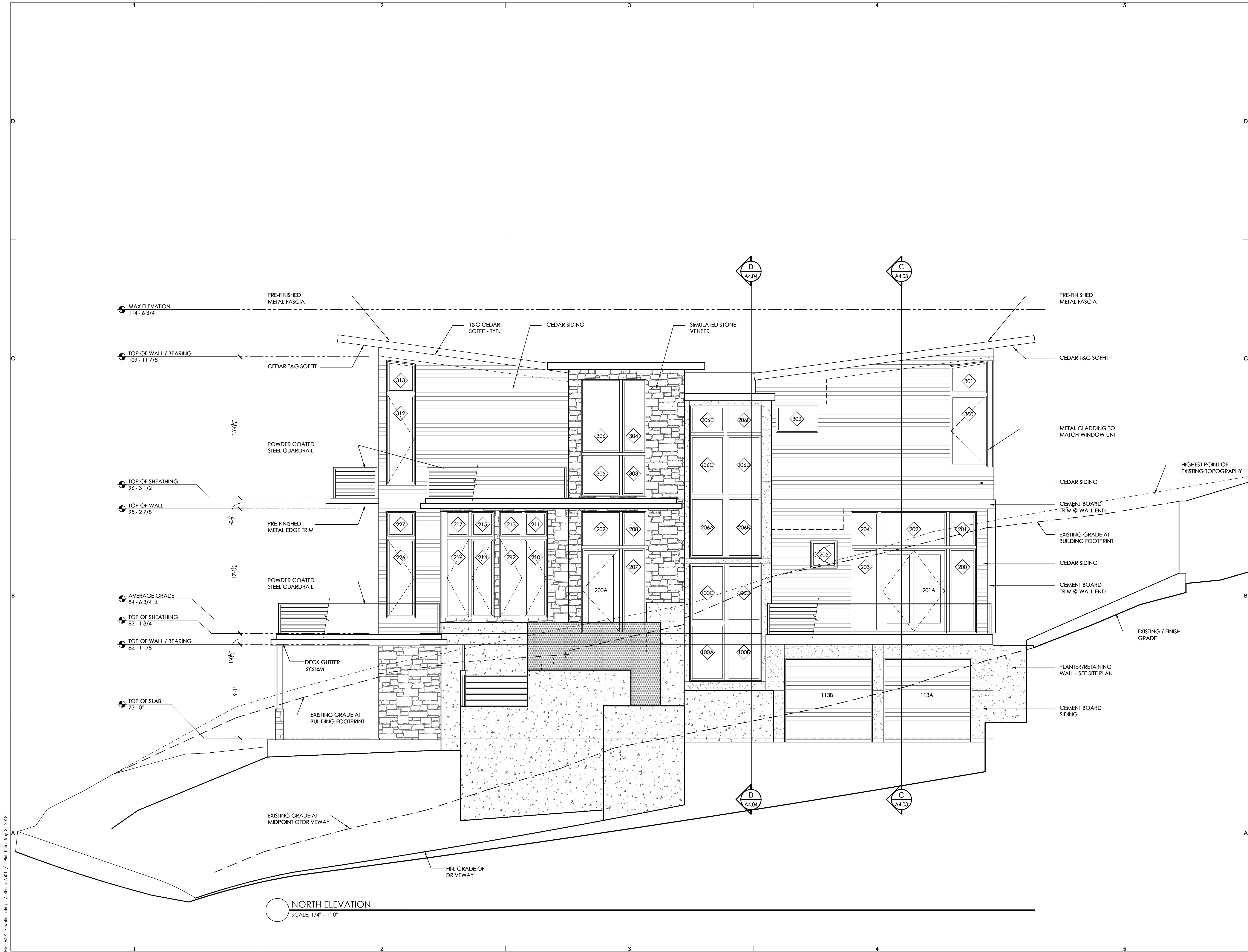

CONSULTANT: _____

PROFESSIONAL SEAL: _____

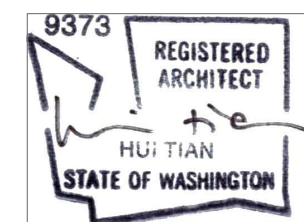

PROJECT: _____

a project for:

PO BOX 1733 AUBURN, WA 98071
Phone: (206) 724-1072

EAST MERCER RESIDENCE

4634 EAST MERCER WAY
MERCER ISLAND, WA 98040

SHEET ISSUE: _____

| MARK | DATE | DESCRIPTION |
|------|------------|--------------------|
| | 6/24/2015 | PERMIT SUBMITTAL |
| | 8/29/2016 | PERMIT APPROVED |
| 1 | 6/05/2017 | REVISION TO PERMIT |
| 2 | 05/08/2018 | REVISION TO PERMIT |

MUNICIPALITY REVIEW: _____

PROJECT # MERCER ISLAND 15 - 015

SHEET TITLE: _____

EAST
EXTERIOR ELEVATION

PROJECT NO.: 20140904

DATE ISSUED: 05/08/2018

SHEET NUMBER: _____

A3.02
Exhibit 5

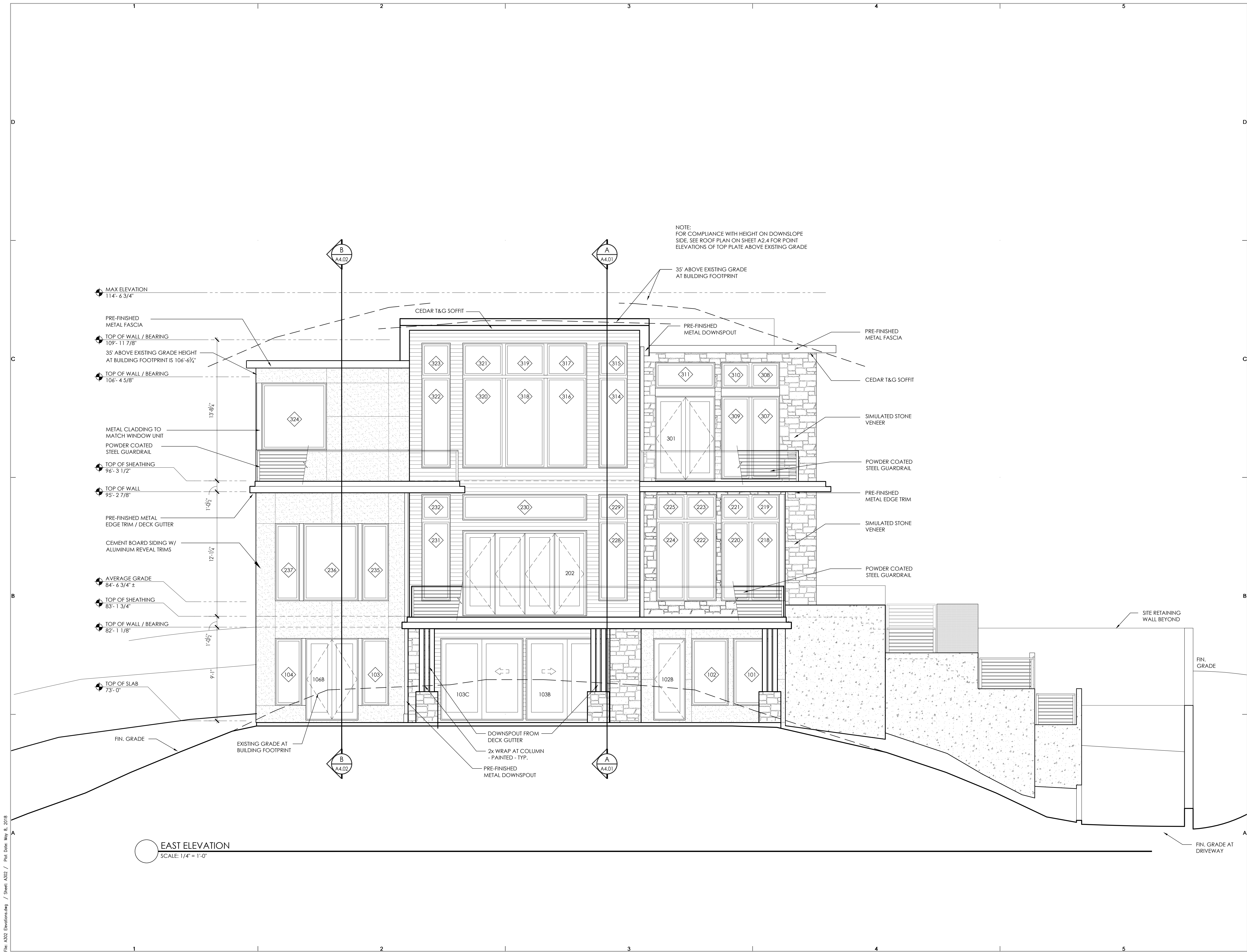

EAST ELEVATION
SCALE: 1/4" = 1'-0"

CONSULTANT: _____

PROFESSIONAL SEAL: _____

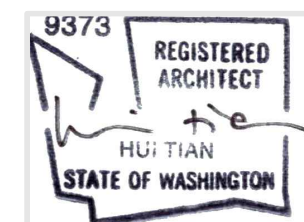

PROJECT: _____

a project for:

 PO BOX 1733 AUBURN, WA 98071
 Phone: (206) 724-1072

EAST MERCER RESIDENCE

4634 EAST MERCER WAY
 MERCER ISLAND, WA 98040

SHEET ISSUE: _____

| | |
|--------------|--------------------|
| 6/24/2015 | PERMIT SUBMITTAL |
| 8/29/2016 | PERMIT APPROVED |
| 1 6/05/2017 | REVISION TO PERMIT |
| 2 05/08/2018 | REVISION TO PERMIT |

| MARK | DATE | DESCRIPTION |
|------|------|-------------|
| | | |
| | | |

MUNICIPALITY REVIEW: _____

PROJECT # MERCER ISLAND 15 - 015

SHEET TITLE: _____

WEST
 EXTERIOR ELEVATION

PROJECT NO.: 20140904

DATE ISSUED: 05/08/2018

SHEET NUMBER: _____

A3.04
 Exhibit 5

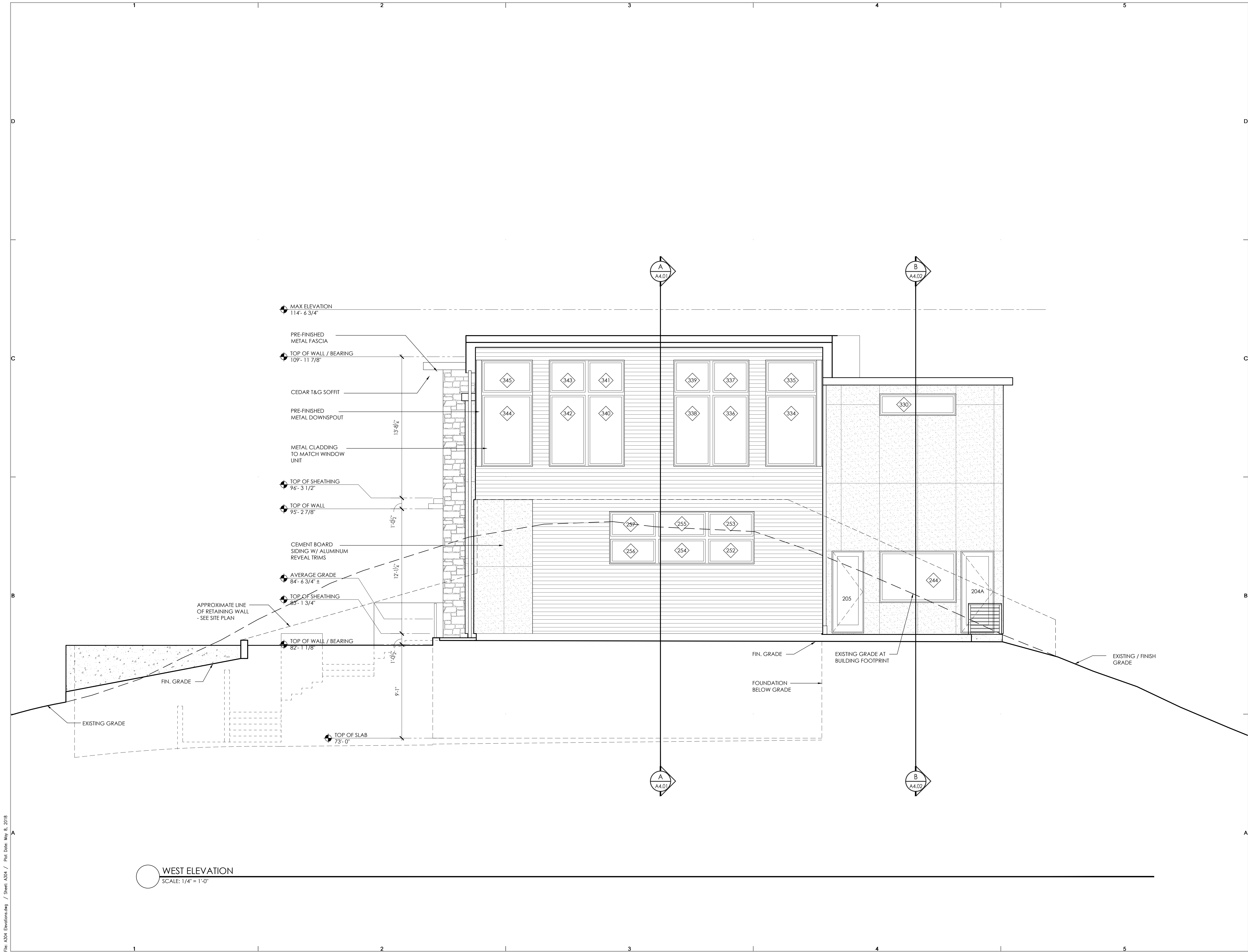

WEST ELEVATION
 SCALE: 1/4" = 1'-0"

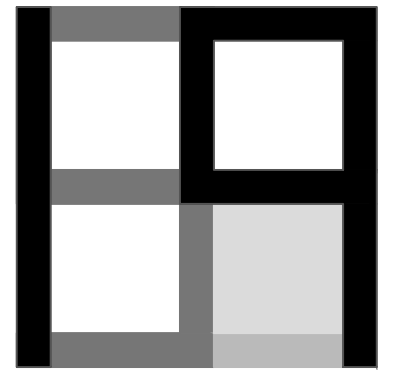

GENERAL NOTES

- HANDRAIL 34" - 38" ABOVE TREAD NOSING. STYLE & CONFIGURATION PER OWNER SELECTION. TBD.
- HANDRAIL GRASPING DIMENSION 1-1/4" MINIMUM - 2" MAXIMUM.
- DECKS, PORCHES, BALCONIES, RAMPS OR RAISED FLOOR SURFACES LOCATED MORE THAN 30 INCHES ABOVE THE FLOOR OR GROUND BELOW SHALL HAVE GUARDRAILS NOT LESS THAN 36 INCHES IN HEIGHT. STYLE & CONFIGURATION PER OWNER SELECTION. TBD.

R1 FLAT ROOF / ROOF DECK ASSEMBLY
3-PLY EPDM SELF-ADHERING MEMBRANE (SELF-ADHERING CAP SHT OVER SELF-ADHERING BASE SHT OVER MECHANICALLY-ADHERED BASE SHT) OVER TAPERED INSULATION (MIN. R-10 AT LOW POINT) OVER 2 LAYERS OF 30 LB. ROOFING FELTS OVER 3/4 PLYWOOD SHEATHING PER STRUCT. OVER 3" (R-21) SPRAY APPLIED CLOSED CELL INSULATION W/ VAPOR BARRIER TO UNDERSIDE OF DECKING R-19 FIBERGLASS BATT INSULATION (FOR TOTAL ASSEMBLY R-VALUE OF R-50) ROOF TRUSSES/FRAMING PER STRUCT. W/ 5/8 GYPSUM WALLBOARD & FINISH PER OWNER SELECTION

R2 FLAT ROOF / ROOF DECK ASSEMBLY
3-PLY EPDM SELF-ADHERING MEMBRANE (SELF-ADHERING CAP SHT OVER SELF-ADHERING BASE SHT OVER MECHANICALLY-ADHERED BASE SHT) OVER 3/4 PLYWOOD SHEATHING PER STRUCT. 5" (R-35) SPRAY APPLIED CLOSED CELL INSULATION W/ VAPOR BARRIER TO UNDERSIDE OF DECKING R-19 FIBERGLASS BATT INSULATION (FOR TOTAL ASSEMBLY R-VALUE OF R-54) ROOF TRUSSES/FRAMING PER STRUCT. W/ 5/8 GYPSUM WALLBOARD & FINISH PER OWNER SELECTION

F1 TYPICAL WOOD FINISH OVER SLAB ON GRADE:
WOOD FINISH PER INTERIORS
REINFORCED CONCRETE SLAB PER STRUCT WITH IN-SLAB HYDRONIC HEATING SYSTEM. W/ THERMAL EXPANSION JOINTS AT WALL 6 MIL VISQUEEN (MIN) VAPOR BARRIER R-10 RIGID FOAM INSULATION 6" MINIMUM COMPACTED GRAVEL BASE OVER UNDISTURBED SOIL

F2 TYPICAL GARAGE FLOOR ASSEMBLY
CONCRETE SEALER
REINFORCED CONCRETE SLAB PER STRUCT., SLOPED TO DRAIN (1/4" PER FT.), 6 MIL POLY VAPOR BARRIER OVER 6" MINIMUM COMPACTED STRUCT. FILL UNDISTURBED SOIL.

F3 TYPICAL FLOOR ASSEMBLY OVER UNHEATED EXTERIOR SPACE
FLOOR FINISH PER INTERIORS
1-1/8" T&G 'WARMBOARD' SUBFLOOR FLOOR SHEATHING (GLUED & SCREWED) WITH HYDRONIC HEATING SYSTEM FLOOR FRAMING PER STRUCTURAL R30 FIBERGLASS BATT INSULATION 6 MIL VISQUEEN VAPOR BARRIER EXTERIOR T&G CEDAR SOFFIT MATERIAL (SMOOTH FACE EXPOSED)

F4 TYPICAL FLOOR ASSEMBLY OVER HEATED SPACE
FLOOR FINISH PER INTERIORS
1-1/8" T&G 'WARMBOARD' SUBFLOOR FLOOR SHEATHING (GLUED & SCREWED) WITH HYDRONIC HEATING SYSTEM FLOOR FRAMING PER STRUCTURAL (2X DROP CEILING /SOFFIT FRAMING AS INDICATED/APPLICABLE) 5/8" GYPSUM WALLBOARD VAPOR BARRIER PVC PRIMER FINISH PER OWNER SELECTION

F5 TYPICAL FLOOR ASSEMBLY OVER GARAGE
FLOOR FINISH PER INTERIORS
1-1/8" T&G 'WARMBOARD' SUBFLOOR FLOOR SHEATHING (GLUED & SCREWED) WITH HYDRONIC HEATING SYSTEM FLOOR FRAMING PER STRUCTURAL R30 FIBERGLASS BATT INSULATION 6 MIL VISQUEEN VAPOR BARRIER 5/8" TYPE X" GWB VAPOR BARRIER PVC PRIMER FINISH PER OWNER SELECTION

F6 TILE FLOOR ASSEMBLY:
TILE (TBD)
THINSET UNDERLAYMENT/ISOLATION MAT TYPICAL FLOOR ASSEMBLY

F7 COMPOSITE WOOD DECKING OVER WATERPROOF DECK ASSEMBLY:
DECKING PER OWNER SELECTION
"DRYJOIST" PVC STRUCTURAL DECK DRAINAGE SYSTEM DECK FRAMING PER STRUCTURAL 2X SOFFIT FURRING STRIPS 3/8" BEVELED SOFFIT BOARDS (SMOOTH FACE EXPOSED) W/ CONTINUOUS STRIP VENTING

S1 TYPICAL DRIVEWAY ASSEMBLY
REINFORCED CONCRETE SLAB PER STRUCT., SLOPED TO DRAIN (1/4" PER FT.), STAINED & SCORED, OVER 6" MINIMUM COMPACTED STRUCT. FILL OVER UNDISTURBED SOIL.

S2 TYPICAL CONCRETE SIDEWALK/STAIR ASSEMBLY
REINFORCED CONCRETE SLAB / STEPS PER STRUCT., SLOPED TO DRAIN (1/4" PER FT.), STAINED & SCORED, OVER 6" MINIMUM COMPACTED STRUCT. FILL OVER UNDISTURBED SOIL.

F8 PATIO PAVERS OVER PIT SET PEDESTAL SYSTEM:
PAVERS PER OWNER SELECTION
LEVELING PEDESTALS CONCRETE SEALER REINFORCED 4" CONCRETE SLAB (SLOPE TO DRAIN 1/4" PER FOOT TO TRENCH DRAIN) 6" MINIMUM COMPACTED SAND BASE OVER UNDISTURBED SOIL.

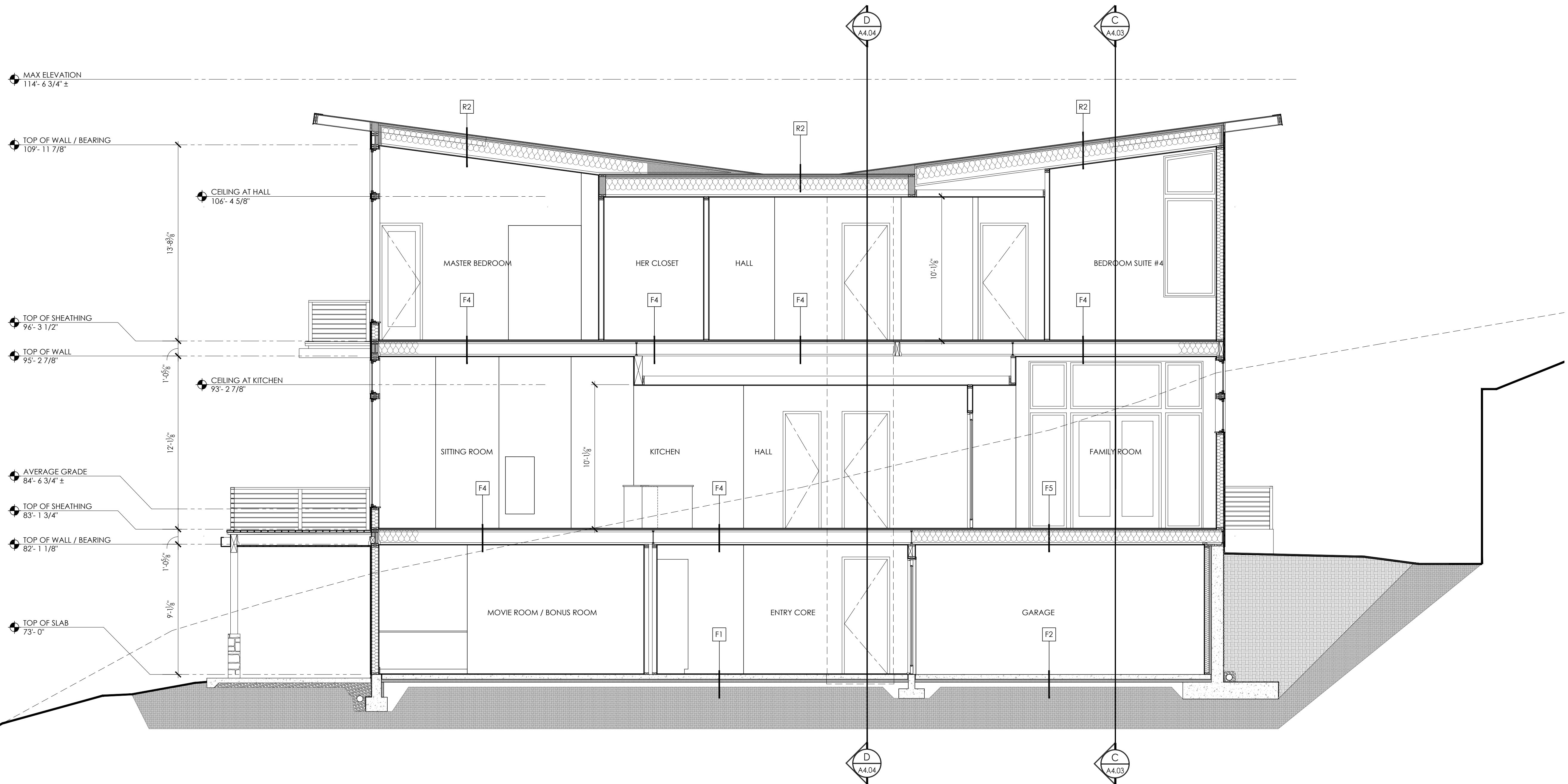

A BUILDING SECTION 'A'
SCALE: 1/4" = 1'-0"

CONSULTANT: _____

PROFESSIONAL SEAL: _____



PROJECT: _____

a project for:
Barcelo homes
PO BOX 1733 AUBURN, WA 98071
Phone: (206) 724-1072

EAST MERCER RESIDENCE

4634 EAST MERCER WAY
MERCER ISLAND, WA 98040

SHEET ISSUE:

| | |
|--------------|--------------------|
| 6/24/2015 | PERMIT SUBMITTAL |
| 8/29/2016 | PERMIT APPROVED |
| 1 06/05/2017 | REVISION TO PERMIT |
| 2 05/08/2018 | REVISION TO PERMIT |

| MARK | DATE | DESCRIPTION |
|------|------|-------------|
|------|------|-------------|

MUNICIPALITY REVIEW:

PROJECT # MERCER ISLAND 15 - 015

SHEET TITLE:

BUILDING SECTION 'A'

PROJECT NO.: 20140904

DATE ISSUED: 05/08/2018

SHEET NUMBER:

A4.01

Exhibit 5

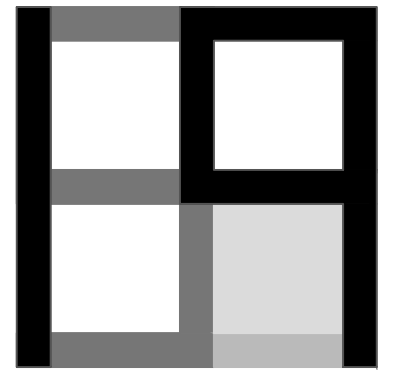

GENERAL NOTES

- HANDRAIL 34" 38" ABOVE TREAD NOSING. STYLE & CONFIGURATION PER OWNER SELECTION. TBD.
- HANDRAIL GRASPING DIMENSION 1-1/4" MINIMUM - 2" MAXIMUM.
- DECKS, PORCHES, BALCONIES, RAMPS OR RAISED FLOOR SURFACES LOCATED MORE THAN 30 INCHES ABOVE THE FLOOR OR GROUND BELOW SHALL HAVE GUARDRAILS NOT LESS THAN 36 INCHES IN HEIGHT. STYLE & CONFIGURATION PER OWNER SELECTION. TBD.

R1 FLAT ROOF / ROOF DECK ASSEMBLY
 3-PLY EPDM SELF-ADHERING MEMBRANE
 (SELF-ADHERING CAP SHT OVER
 SELF-ADHERING BASE SHT OVER
 MECHANICALLY-ADHERED BASE SHT) OVER
 TAPERED INSULATION (MIN. R-10 AT LOW POINT) OVER
 2 LAYERS OF 30 LB. ROOFING FELTS OVER
 3/4 PLYWOOD SHEATHING PER STRUCT. OVER
 3" (R-21) SPRAY APPLIED CLOSED CELL INSULATION
 W/ VAPOR BARRIER TO UNDERSIDE OF DECKING
 R-19 FIBERGLASS BATT INSULATION
 (FOR TOTAL ASSEMBLY R-VALUE OF R-50)
 ROOF TRUSSES/FRAMING PER STRUCT. W/
 5/8 GYPSUM WALLBOARD &
 FINISH PER OWNER SELECTION

R2 FLAT ROOF / ROOF DECK ASSEMBLY
 3-PLY EPDM SELF-ADHERING MEMBRANE
 (SELF-ADHERING CAP SHT OVER
 SELF-ADHERING BASE SHT OVER
 MECHANICALLY-ADHERED BASE SHT)
 3/4 PLYWOOD SHEATHING PER STRUCT.
 5" (R-35) SPRAY APPLIED CLOSED CELL INSULATION
 W/ VAPOR BARRIER TO UNDERSIDE OF DECKING
 R-19 FIBERGLASS BATT INSULATION
 (FOR TOTAL ASSEMBLY R-VALUE OF R-54)
 ROOF TRUSSES/FRAMING PER STRUCT. W/
 5/8 GYPSUM WALLBOARD &
 FINISH PER OWNER SELECTION

F1 TYPICAL WOOD FINISH OVER SLAB ON GRADE:
 WOOD FINISH PER INTERIORS
 REINFORCED CONCRETE SLAB PER STRUCT.
 WITH IN-SLAB HYDRONIC HEATING SYSTEM.
 W/ THERMAL EXPANSION JOINTS AT WALL
 6 MIL VISQUEEN (MIN) VAPOR BARRIER
 R-10 RIGID FOAM INSULATION
 6" MINIMUM COMPACTED GRAVEL BASE OVER
 UNDISTURBED SOIL

F2 TYPICAL GARAGE FLOOR ASSEMBLY
 CONCRETE SEALER
 REINFORCED CONCRETE SLAB PER STRUCT.,
 SLOPED TO DRAIN (1/4" PER FT.),
 6 MIL POLY VAPOR BARRIER OVER
 6" MINIMUM COMPACTED STRUCT. FILL
 UNDISTURBED SOIL.

F3 TYPICAL FLOOR ASSEMBLY OVER UNHEATED EXTERIOR SPACE
 FLOOR FINISH PER INTERIORS
 1-1/8" T&G 'WARMBOARD' SUBFLOOR FLOOR SHEATHING
 (GLUED & SCREWED) WITH HYDRONIC HEATING SYSTEM
 FLOOR FRAMING PER STRUCTURAL
 R30 FIBERGLASS BATT INSULATION
 6 MIL VISQUEEN VAPOR BARRIER
 EXTERIOR T&G CEDAR SOFFIT MATERIAL
 (SMOOTH FACE EXPOSED)

F4 TYPICAL FLOOR ASSEMBLY OVER HEATED SPACE
 FLOOR FINISH PER INTERIORS
 1-1/8" T&G 'WARMBOARD' SUBFLOOR FLOOR SHEATHING
 (GLUED & SCREWED) WITH HYDRONIC HEATING SYSTEM
 FLOOR FRAMING PER STRUCTURAL
 (2X DROP CEILING /SOFFIT FRAMING AS INDICATED/APPLICABLE)
 5/8" GYPSUM WALLBOARD
 VAPOR BARRIER PVC PRIMER
 FINISH PER OWNER SELECTION

F5 TYPICAL FLOOR ASSEMBLY OVER GARAGE
 FLOOR FINISH PER INTERIORS
 1-1/8" T&G 'WARMBOARD' SUBFLOOR FLOOR SHEATHING
 (GLUED & SCREWED) WITH HYDRONIC HEATING SYSTEM
 FLOOR FRAMING PER STRUCTURAL
 R30 FIBERGLASS BATT INSULATION
 6 MIL VISQUEEN VAPOR BARRIER
 5/8" TYPE X" GWB
 VAPOR BARRIER PVC PRIMER
 FINISH PER OWNER SELECTION

F6 TILE FLOOR ASSEMBLY:
 TILE (TBD)
 THINSET
 UNDERLAYMENT/ISOLATION MAT
 TYPICAL FLOOR ASSEMBLY

F7 COMPOSITE WOOD DECKING OVER WATERPROOF DECK
 ASSEMBLY:
 DECKING PER OWNER SELECTION
 "DRYJOIST" PVC STRUCTURAL DECK DRAINAGE SYSTEM
 DECK FRAMING PER STRUCTURAL
 2X SOFFIT FURRING STRIPS
 3/8" BEVELED SOFFIT BOARDS (SMOOTH FACE EXPOSED) W/
 CONTINUOUS STRIP VENTING

S1 TYPICAL DRIVEWAY ASSEMBLY
 REINFORCED CONCRETE SLAB PER STRUCT.,
 SLOPED TO DRAIN (1/4" PER FT.),
 STAINED & SCORED, OVER
 6" MINIMUM COMPACTED STRUCT. FILL OVER
 UNDISTURBED SOIL.

S2 TYPICAL CONCRETE SIDEWALK/STAIR ASSEMBLY
 REINFORCED CONCRETE SLAB / STEPS PER STRUCT.,
 SLOPED TO DRAIN (1/4" PER FT.),
 STAINED & SCORED, OVER
 6" MINIMUM COMPACTED STRUCT. FILL OVER
 UNDISTURBED SOIL.

F8 PATIO PAVERS OVER PIT SET PEDESTAL SYSTEM:
 PAVERS PER OWNER SELECTION
 LEVELING PEDESTALS
 CONCRETE SEALER
 REINFORCED 4" CONCRETE SLAB (SLOPE TO DRAIN 1/4" PER FOOT TO
 TRENCH DRAIN)
 6" MINIMUM COMPACTED SAND BASE OVER
 UNDISTURBED SOIL.

MAX ELEVATION
 114'-6 3/4" ±

TOP OF WALL / BEARING
 106'-4 5/8"

TOP OF SHEATHING
 96'-3 1/2"

TOP OF WALL
 95'-2 7/8"

AVERAGE GRADE
 84'-6 3/4" ±

TOP OF SHEATHING
 83'-1 3/4"

TOP OF WALL / BEARING
 82'-1 1/8"

TOP OF SLAB
 73'-0"

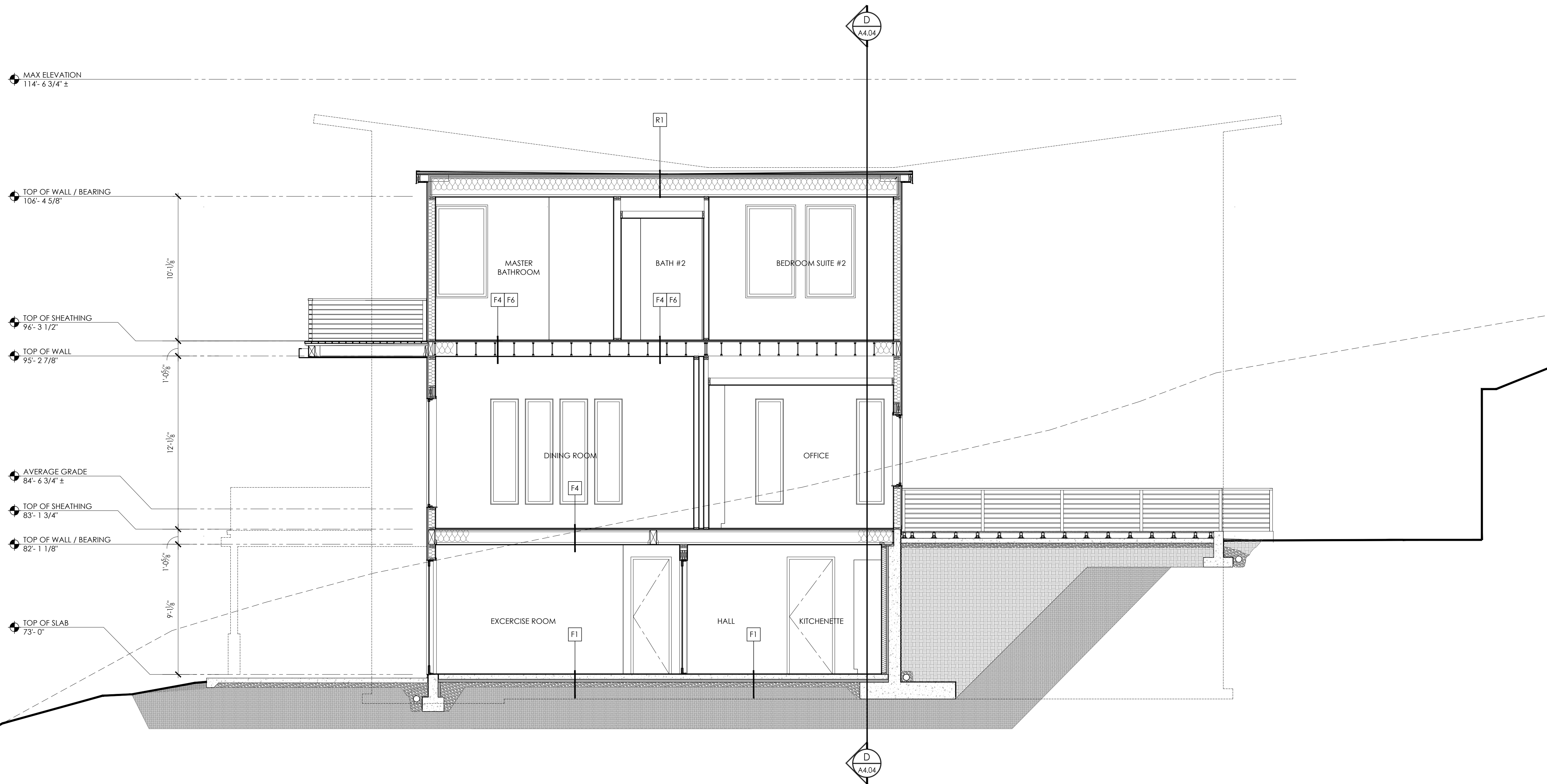

B BUILDING SECTION 'B'
 SCALE: 1/4" = 1'-0"

CONSULTANT: _____

PROFESSIONAL SEAL: _____



PROJECT: _____

a project for:

 PO BOX 1733 AUBURN, WA 98071
 Phone: (206) 724-1072

EAST MERCER RESIDENCE

4634 EAST MERCER WAY
 MERCER ISLAND, WA 98040

SHEET ISSUE:

| | |
|--------------|--------------------|
| 6/24/2015 | PERMIT SUBMITTAL |
| 8/29/2016 | PERMIT APPROVED |
| 1 08/05/2017 | REVISION TO PERMIT |
| 2 05/08/2018 | REVISION TO PERMIT |

| MARK | DATE | DESCRIPTION |
|------|------|-------------|
|------|------|-------------|

MUNICIPALITY REVIEW:

PROJECT # MERCER ISLAND 15 - 015

SHEET TITLE:

BUILDING SECTION 'B'

PROJECT NO.: 20140904

DATE ISSUED: 05/08/2018

SHEET NUMBER:

A4.02

Exhibit 5

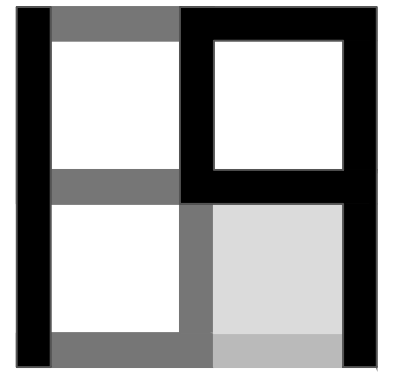

GENERAL NOTES

- HANDRAIL 34" 38" ABOVE TREAD NOSING. STYLE & CONFIGURATION PER OWNER SELECTION. TBD.
- HANDRAIL GRASPING DIMENSION 1-1/4" MINIMUM - 2" MAXIMUM.
- DECKS, PORCHES, BALCONIES, RAMPS OR RAISED FLOOR SURFACES LOCATED MORE THAN 30 INCHES ABOVE THE FLOOR OR GROUND BELOW SHALL HAVE GUARDRAILS NOT LESS THAN 36 INCHES IN HEIGHT. STYLE & CONFIGURATION PER OWNER SELECTION. TBD.

CONSULTANT: _____

PROFESSIONAL SEAL: _____

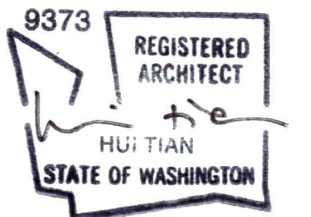

PROJECT: _____

a project for:
Barcelo homes
 PO BOX 1733 AUBURN, WA 98071
 Phone: (206) 724-1072

EAST MERCER RESIDENCE

4634 EAST MERCER WAY
MERCER ISLAND, WA 98040

SHEET ISSUE:

| | |
|--------------|--------------------|
| 6/24/2015 | PERMIT SUBMITTAL |
| 8/29/2016 | PERMIT APPROVED |
| 1 6/05/2017 | REVISION TO PERMIT |
| 2 05/08/2018 | REVISION TO PERMIT |

| MARK | DATE | DESCRIPTION |
|------|------|-------------|
| | | |
| | | |

MUNICIPALITY REVIEW:

PROJECT # MERCER ISLAND 15 - 015

SHEET TITLE:

BUILDING SECTION 'C'

PROJECT NO.: 20140904

DATE ISSUED: 05/08/2018

SHEET NUMBER:

A4.03
Exhibit 5

R1 FLAT ROOF / ROOF DECK ASSEMBLY
 3-PLY EPDM SELF-ADHERING MEMBRANE
 (SELF-ADHERING CAP SHT OVER
 SELF-ADHERING BASE SHT OVER
 MECHANICALLY-ADHERED BASE SHT) OVER
 TAPERED INSULATION (MIN. R-10 AT LOW POINT) OVER
 2 LAYERS OF 30 LB. ROOFING FELTS OVER
 3/4 PLYWOOD SHEATHING PER STRUCT. OVER
 3" (R-21) SPRAY APPLIED CLOSED CELL INSULATION
 W/ VAPOR BARRIER TO UNDERSIDE OF DECKING
 R-19 FIBERGLASS BATT INSULATION
 (FOR TOTAL ASSEMBLY R-VALUE OF R-50)
 ROOF TRUSSES/FRAMING PER STRUCT. W/
 5/8 GYPSUM WALLBOARD &
 FINISH PER OWNER SELECTION

R2 FLAT ROOF / ROOF DECK ASSEMBLY
 3-PLY EPDM SELF-ADHERING MEMBRANE
 (SELF-ADHERING CAP SHT OVER
 SELF-ADHERING BASE SHT OVER
 MECHANICALLY-ADHERED BASE SHT)
 3/4 PLYWOOD SHEATHING PER STRUCT.
 5" (R-35) SPRAY APPLIED CLOSED CELL INSULATION
 W/ VAPOR BARRIER TO UNDERSIDE OF DECKING
 R-19 FIBERGLASS BATT INSULATION
 (FOR TOTAL ASSEMBLY R-VALUE OF R-54)
 ROOF TRUSSES/FRAMING PER STRUCT. W/
 5/8 GYPSUM WALLBOARD &
 FINISH PER OWNER SELECTION

F1 TYPICAL WOOD FINISH OVER SLAB ON GRADE:
 WOOD FINISH PER INTERIORS
 REINFORCED CONCRETE SLAB PER STRUCT
 WITH IN-SLAB HYDRONIC HEATING SYSTEM.
 W/ THERMAL EXPANSION JOINTS AT WALL
 6 MIL VISQUEEN (MIN) VAPOR BARRIER
 R-10 RIGID FOAM INSULATION
 6" MINIMUM COMPACTED GRAVEL BASE OVER
 UNDISTURBED SOIL

F2 TYPICAL GARAGE FLOOR ASSEMBLY
 CONCRETE SEALER
 REINFORCED CONCRETE SLAB PER STRUCT.,
 SLOPED TO DRAIN (1/4" PER FT.),
 6 MIL POLY VAPOR BARRIER OVER
 6" MINIMUM COMPACTED STRUCT. FILL
 UNDISTURBED SOIL.

F3 TYPICAL FLOOR ASSEMBLY OVER UNHEATED EXTERIOR SPACE
 FLOOR FINISH PER INTERIORS
 1-1/8" T&G 'WARMBOARD' SUBFLOOR FLOOR SHEATHING
 (GLUED & SCREWED) WITH HYDRONIC HEATING SYSTEM
 FLOOR FRAMING PER STRUCTURAL
 R30 FIBERGLASS BATT INSULATION
 6 MIL VISQUEEN VAPOR BARRIER
 EXTERIOR T&G CEDAR SOFFIT MATERIAL
 (SMOOTH FACE EXPOSED)

F4 TYPICAL FLOOR ASSEMBLY OVER HEATED SPACE
 FLOOR FINISH PER INTERIORS
 1-1/8" T&G 'WARMBOARD' SUBFLOOR FLOOR SHEATHING
 (GLUED & SCREWED) WITH HYDRONIC HEATING SYSTEM
 FLOOR FRAMING PER STRUCTURAL
 (2X DROP CEILING /SOFFIT FRAMING AS INDICATED/APPLICABLE)
 5/8" GYPSUM WALLBOARD
 VAPOR BARRIER PVC PRIMER
 FINISH PER OWNER SELECTION

F5 TYPICAL FLOOR ASSEMBLY OVER GARAGE
 FLOOR FINISH PER INTERIORS
 1-1/8" T&G 'WARMBOARD' SUBFLOOR FLOOR SHEATHING
 (GLUED & SCREWED) WITH HYDRONIC HEATING SYSTEM
 FLOOR FRAMING PER STRUCTURAL
 R30 FIBERGLASS BATT INSULATION
 6 MIL VISQUEEN VAPOR BARRIER
 5/8" TYPE X" GWB
 VAPOR BARRIER PVC PRIMER
 FINISH PER OWNER SELECTION

F6 TILE FLOOR ASSEMBLY:
 TILE (TBD)
 THINSET
 UNDERLAYMENT/ISOLATION MAT
 TYPICAL FLOOR ASSEMBLY

F7 COMPOSITE WOOD DECKING OVER WATERPROOF DECK
 ASSEMBLY:
 DECKING PER OWNER SELECTION
 "DRYJOIST" PVC STRUCTURAL DECK DRAINAGE SYSTEM
 DECK FRAMING PER STRUCTURAL
 2X SOFFIT FURRING STRIPS
 3/8" BEVELED SOFFIT BOARDS (SMOOTH FACE EXPOSED) W/
 CONTINUOUS STRIP VENTING

S1 TYPICAL DRIVEWAY ASSEMBLY
 REINFORCED CONCRETE SLAB PER STRUCT.,
 SLOPED TO DRAIN (1/4" PER FT.),
 STAINED & SCORED, OVER
 6" MINIMUM COMPACTED STRUCT. FILL OVER
 UNDISTURBED SOIL.

S2 TYPICAL CONCRETE SIDEWALK/STAIR ASSEMBLY
 REINFORCED CONCRETE SLAB / STEPS PER STRUCT.,
 SLOPED TO DRAIN (1/4" PER FT.),
 STAINED & SCORED, OVER
 6" MINIMUM COMPACTED STRUCT. FILL OVER
 UNDISTURBED SOIL.

F8 PATIO PAVERS OVER PIT SET PEDESTAL SYSTEM:
 PAVERS PER OWNER SELECTION
 LEVELING PEDESTALS
 CONCRETE SEALER
 REINFORCED 4" CONCRETE SLAB (SLOPE TO DRAIN 1/4" PER FOOT TO
 TRENCH DRAIN)
 6" MINIMUM COMPACTED SAND BASE OVER
 UNDISTURBED SOIL.

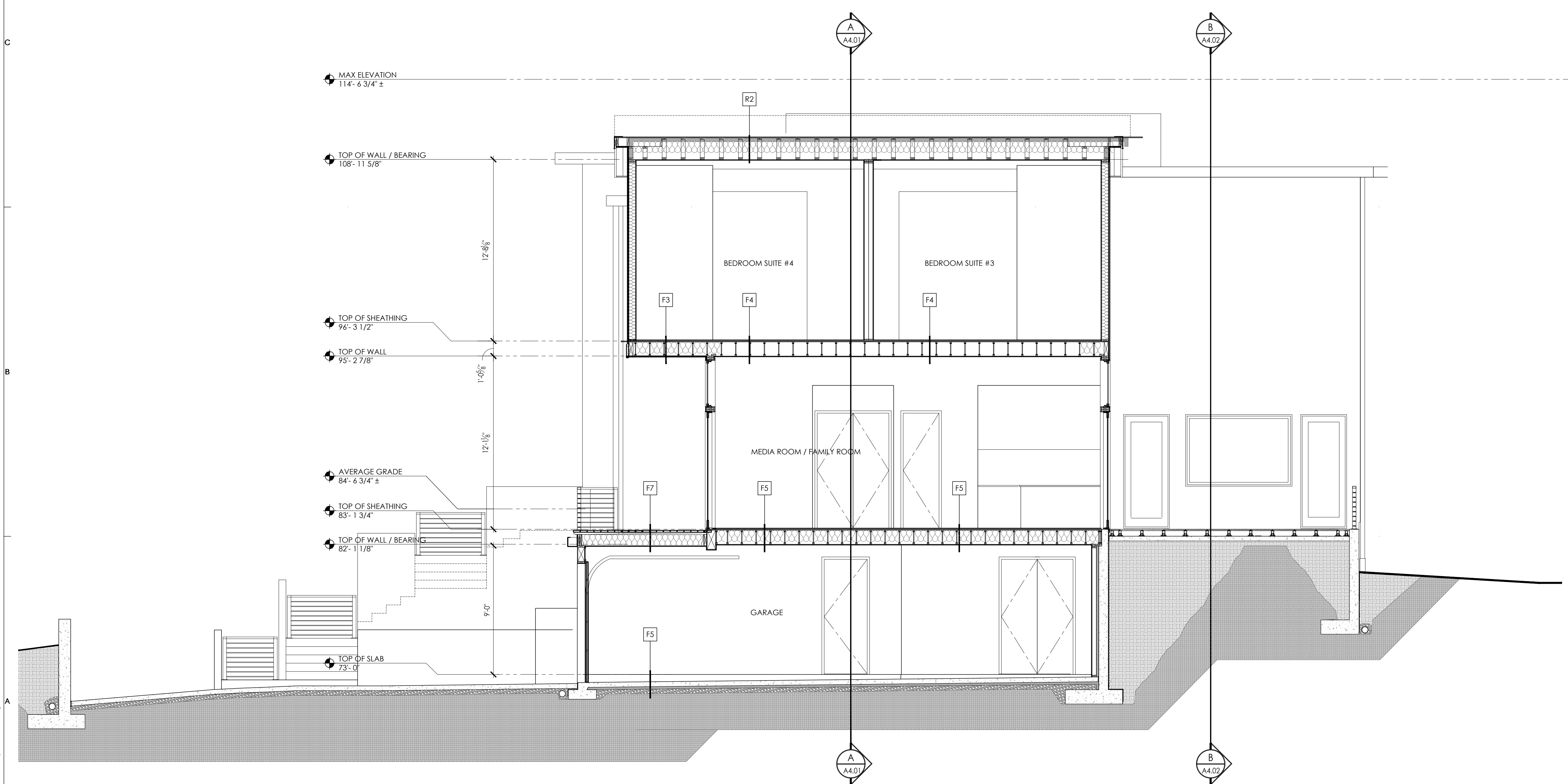

C BUILDING SECTION 'C'
SCALE: 1/4" = 1'-0"

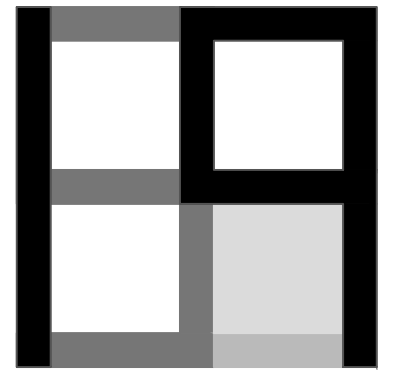

GENERAL NOTES

- HANDRAIL 34" 38" ABOVE TREAD NOSING. STYLE & CONFIGURATION PER OWNER SELECTION. TBD.
- HANDRAIL GRASPING DIMENSION 1-1/4" MINIMUM - 2" MAXIMUM.
- DECKS, PORCHES, BALCONIES, RAMPS OR RAISED FLOOR SURFACES LOCATED MORE THAN 30 INCHES ABOVE THE FLOOR OR GROUND BELOW SHALL HAVE GUARDRAILS NOT LESS THAN 36 INCHES IN HEIGHT. STYLE & CONFIGURATION PER OWNER SELECTION. TBD.

R1 FLAT ROOF / ROOF DECK ASSEMBLY
 3-PLY EPDM SELF-ADHERING MEMBRANE
 (SELF-ADHERING CAP SHT OVER
 SELF-ADHERING BASE SHT OVER
 MECHANICALLY-ADHERED BASE SHT) OVER
 TAPERED INSULATION (MIN. R-10 AT LOW POINT) OVER
 2 LAYERS OF 30 LB. ROOFING FELTS OVER
 3/4 PLYWOOD SHEATHING PER STRUCT. OVER
 3" (R-21) SPRAY APPLIED CLOSED CELL INSULATION
 W/ VAPOR BARRIER TO UNDERSIDE OF DECKING
 R-19 FIBERGLASS BATT INSULATION
 (FOR TOTAL ASSEMBLY R-VALUE OF R-50)
 ROOF TRUSSES/FRAMING PER STRUCT. W/
 5/8 GYPSUM WALLBOARD &
 FINISH PER OWNER SELECTION

R2 FLAT ROOF / ROOF DECK ASSEMBLY
 3-PLY EPDM SELF-ADHERING MEMBRANE
 (SELF-ADHERING CAP SHT OVER
 SELF-ADHERING BASE SHT OVER
 MECHANICALLY-ADHERED BASE SHT)
 3/4 PLYWOOD SHEATHING PER STRUCT.
 5" (R-35) SPRAY APPLIED CLOSED CELL INSULATION
 W/ VAPOR BARRIER TO UNDERSIDE OF DECKING
 R-19 FIBERGLASS BATT INSULATION
 (FOR TOTAL ASSEMBLY R-VALUE OF R-54)
 ROOF TRUSSES/FRAMING PER STRUCT. W/
 5/8 GYPSUM WALLBOARD &
 FINISH PER OWNER SELECTION

F1 TYPICAL WOOD FINISH OVER SLAB ON GRADE:
 WOOD FINISH PER INTERIORS
 REINFORCED CONCRETE SLAB PER STRUCT
 WITH IN-SLAB HYDRONIC HEATING SYSTEM
 W/ THERMAL EXPANSION JOINTS AT WALL
 6 MIL VISQUEEN (MIN) VAPOR BARRIER
 R-10 RIGID FOAM INSULATION
 6" MINIMUM COMPACTED GRAVEL BASE OVER
 UNDISTURBED SOIL

F2 TYPICAL GARAGE FLOOR ASSEMBLY
 CONCRETE SEALER
 REINFORCED CONCRETE SLAB PER STRUCT.,
 SLOPED TO DRAIN (1/4" PER FT.),
 6 MIL POLY VAPOR BARRIER OVER
 6" MINIMUM COMPACTED STRUCT. FILL
 UNDISTURBED SOIL.

F3 TYPICAL FLOOR ASSEMBLY OVER UNHEATED EXTERIOR SPACE
 FLOOR FINISH PER INTERIORS
 1-1/8" T&G 'WARMBOARD' SUBFLOOR FLOOR SHEATHING
 (GLUED & SCREWED) WITH HYDRONIC HEATING SYSTEM
 FLOOR FRAMING PER STRUCTURAL
 R30 FIBERGLASS BATT INSULATION
 6 MIL VISQUEEN VAPOR BARRIER
 EXTERIOR T&G CEDAR SOFFIT MATERIAL
 (SMOOTH FACE EXPOSED)

F4 TYPICAL FLOOR ASSEMBLY OVER HEATED SPACE
 FLOOR FINISH PER INTERIORS
 1-1/8" T&G 'WARMBOARD' SUBFLOOR FLOOR SHEATHING
 (GLUED & SCREWED) WITH HYDRONIC HEATING SYSTEM
 FLOOR FRAMING PER STRUCTURAL
 (2X DROP CEILING /SOFFIT FRAMING AS INDICATED/APPLICABLE)
 5/8" GYPSUM WALLBOARD
 VAPOR BARRIER PVC PRIMER
 FINISH PER OWNER SELECTION

F5 TYPICAL FLOOR ASSEMBLY OVER GARAGE
 FLOOR FINISH PER INTERIORS
 1-1/8" T&G 'WARMBOARD' SUBFLOOR FLOOR SHEATHING
 (GLUED & SCREWED) WITH HYDRONIC HEATING SYSTEM
 FLOOR FRAMING PER STRUCTURAL
 R30 FIBERGLASS BATT INSULATION
 6 MIL VISQUEEN VAPOR BARRIER
 5/8" TYPE X" GWB
 VAPOR BARRIER PVC PRIMER
 FINISH PER OWNER SELECTION

F6 TILE FLOOR ASSEMBLY:
 TILE (TBD)
 THINSET
 UNDERLAYMENT/ISOLATION MAT
 TYPICAL FLOOR ASSEMBLY

S1 TYPICAL DRIVEWAY ASSEMBLY
 REINFORCED CONCRETE SLAB PER STRUCT.,
 SLOPED TO DRAIN (1/4" PER FT.),
 STAINED & SCORED, OVER
 6" MINIMUM COMPACTED STRUCT. FILL OVER
 UNDISTURBED SOIL.

S2 TYPICAL CONCRETE SIDEWALK/STAIR ASSEMBLY
 REINFORCED CONCRETE SLAB / STEPS PER STRUCT.,
 SLOPED TO DRAIN (1/4" PER FT.),
 STAINED & SCORED, OVER
 6" MINIMUM COMPACTED STRUCT. FILL OVER
 UNDISTURBED SOIL.

F8 PATIO PAVERS OVER PIT SET PEDESTAL SYSTEM:
 PAVERS PER OWNER SELECTION
 LEVELING PEDESTALS
 CONCRETE SEALER
 REINFORCED 4" CONCRETE SLAB (SLOPE TO DRAIN 1/4" PER FOOT TO
 TRENCH DRAIN)
 6" MINIMUM COMPACTED SAND BASE OVER
 UNDISTURBED SOIL.

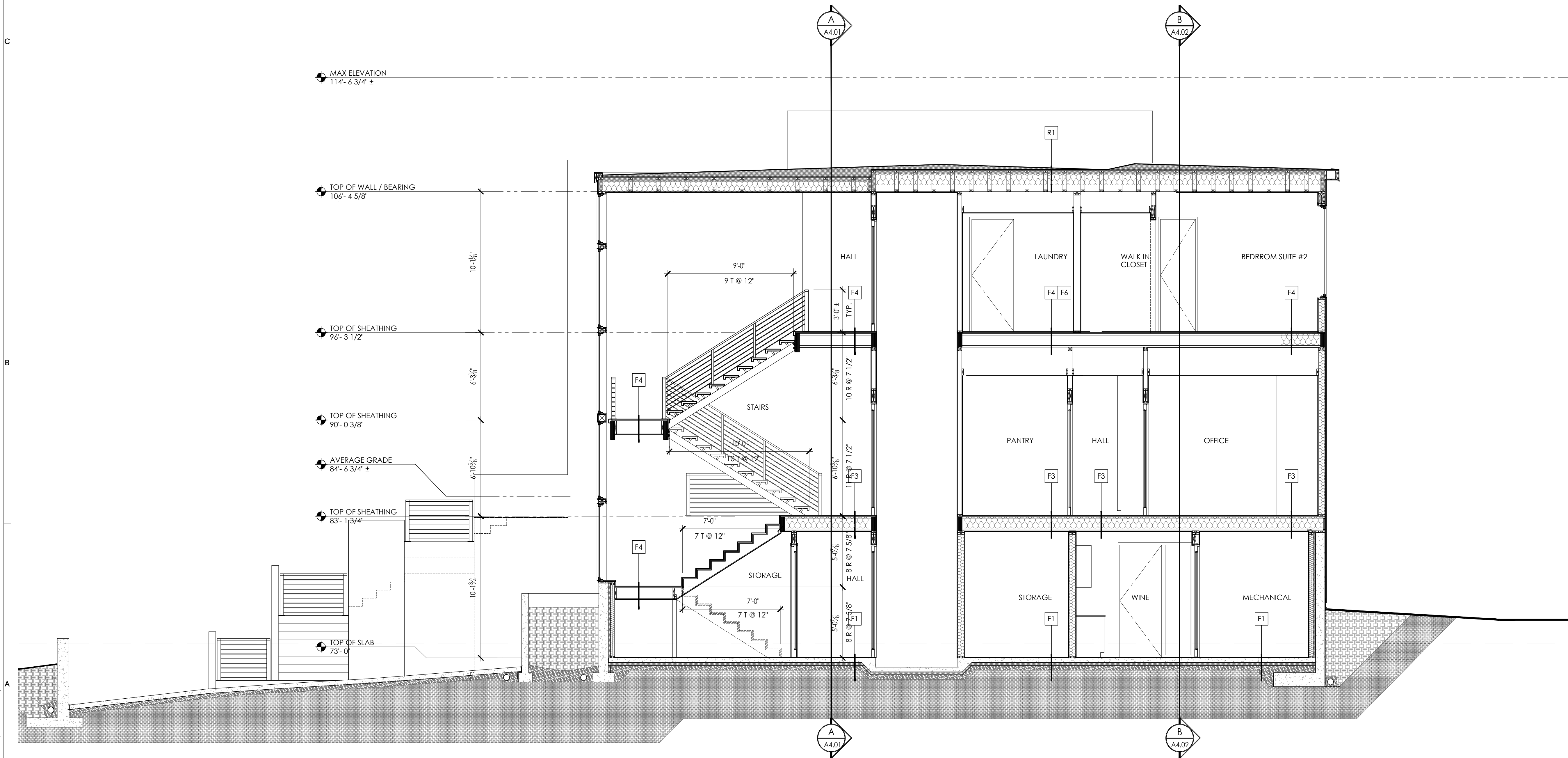

D BUILDING SECTION 'D'
 SCALE: 1/4" = 1'-0"

File: A04_Section.dwg / Sheet: A04 / Plt. Date: May 8, 2018

CONSULTANT: _____

PROFESSIONAL SEAL: _____



PROJECT: _____

a project for:

 PO BOX 1733 AUBURN, WA 98071
 Phone: (206) 724-1072

EAST MERCER RESIDENCE

4634 EAST MERCER WAY
 MERCER ISLAND, WA 98040

SHEET ISSUE:

| | |
|--------------|--------------------|
| 6/24/2015 | PERMIT SUBMITTAL |
| 8/29/2016 | PERMIT APPROVED |
| 1 6/05/2017 | REVISION TO PERMIT |
| 2 05/08/2018 | REVISION TO PERMIT |

| MARK | DATE | DESCRIPTION |
|------|------|-------------|
| | | |
| | | |

MUNICIPALITY REVIEW: _____

PROJECT # MERCER ISLAND 15 - 015

SHEET TITLE:

BUILDING SECTION 'D'

PROJECT NO.: 20140904

DATE ISSUED: 05/08/2018

SHEET NUMBER:

A4.04
 Exhibit 5

W.R.B. & FLASHING SEQUENCE AT BUILDING PENETRATIONS

NOTES

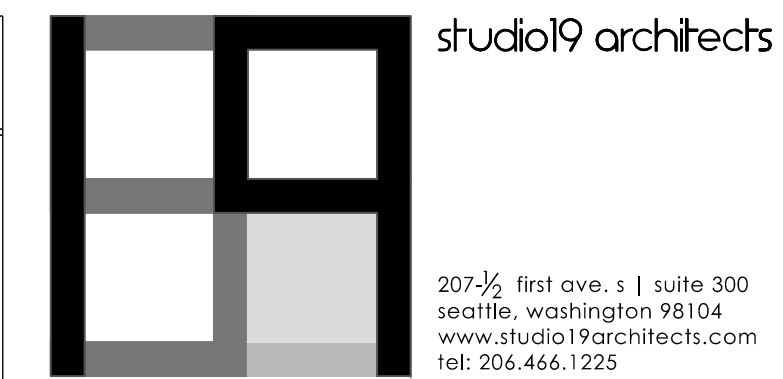

NOTE:
CONTRACTOR SHALL CONFIRM COMPATIBILITY OF ALL MATERIALS USED IN PENETRATION FLASHING SEQUENCE. USE SIMILAR METHODS AT EACH BUILDING PENETRATION.

MATERIALS / ASSEMBLIES:

- CONTRACTOR SHALL BE RESPONSIBLE FOR PROVIDING ALL WORK AND MATERIALS IN ACCORDANCE WITH ALL APPLICABLE COUNTY, AND LOCAL BUILDING AND FIRE CODES AS REQUIRED.
- ALL WOOD AND SONITUBE FORMS USED FOR CONCRETE IN THE GROUND OR BETWEEN FOUNDATION SILLS & THE GROUND SHALL BE REMOVED.
- ALL WOOD IN CONTACT WITH CONCRETE OR MASONRY SHALL BE PRESSURE TREATED WOOD OR ANY SPECIES OR FOUNDATION GRADE CEDAR OR REDWOOD, ALL MARKED BY AN APPROVED TESTING AGENCY.
- PROVIDE 90# FELT BETWEEN POSTS & CONCRETE.
- PROVIDE DRAFT STOPS, FIRE BLOCKING, AND FIRESTOPS AS REQUIRED BY CODE.
- FLASHING AND COUNTER FLASHING TO BE MIN. 24 GAUGE OF CORROSION-RESISTANT METAL AND SHALL BE INSTALLED IN COMPLIANCE WITH LOCAL BUILDING CODES AND MANUFACTURERS RECOMMENDATIONS.
- GENERAL CONTRACTOR SHALL PROVIDE BLOCKING FOR ALL WALL-MOUNTED HARDWARE, TOILET ACCESSORIES, TOWEL BARS, LIGHT FIXTURES, BUILT-INS, ETC., AS REQUIRED FOR SECURE AND PROPER INSTALLATION.
- ALL WOOD EXPOSED TO WEATHER SHALL BE PRESSURE TREATED OR CEDAR.
- ALL STRUCTURAL PANEL COMPONENTS OF THE RESIDENCE SHALL COMPLY WITH APPROPRIATE STANDARDS FOR THE EMISSION OF FORMALDEHYDE. THE BACK-DRAFTING OF COMBUSTION BY PRODUCTS FROM COMBUSTION APPLIANCES SHALL BE MINIMIZED THROUGH THE USE OF DAMPERS, VENTS, OUTSIDE COMBUSTION AIR SOURCES, OR OTHER APPROPRIATE TECHNOLOGIES [RCW 19.27.190(VER)1]

CONSULTANT: _____

PROFESSIONAL SEAL: _____

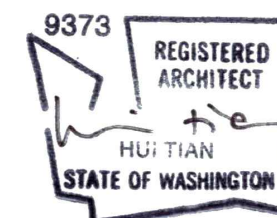

PROJECT: _____

a project for:
Barcelo homes
PO BOX 1733 AUBURN, WA 98071
Phone: (206) 724-1072

EAST MERCER RESIDENCE

4634 EAST MERCER WAY
MERCER ISLAND, WA 98040

SHEET ISSUE:

| | |
|--------------|--------------------|
| 6/24/2015 | PERMIT SUBMITTAL |
| 8/29/2016 | PERMIT APPROVED |
| 1 6/05/2017 | REVISION TO PERMIT |
| 2 05/08/2018 | REVISION TO PERMIT |

MARK DATE DESCRIPTION

MUNICIPALITY REVIEW:

PROJECT # MERCER ISLAND 15 - 015

SHEET TITLE:

TYPICAL WALL, FLOOR, & ROOF ASSEMBLIES
W.R.B. & FLASHING SEQUENCE AT
BUILDING PENETRATIONS

PROJECT NO.: 20140904

DATE ISSUED: 05/08/2018

SHEET NUMBER: _____

A8.01
Exhibit 5

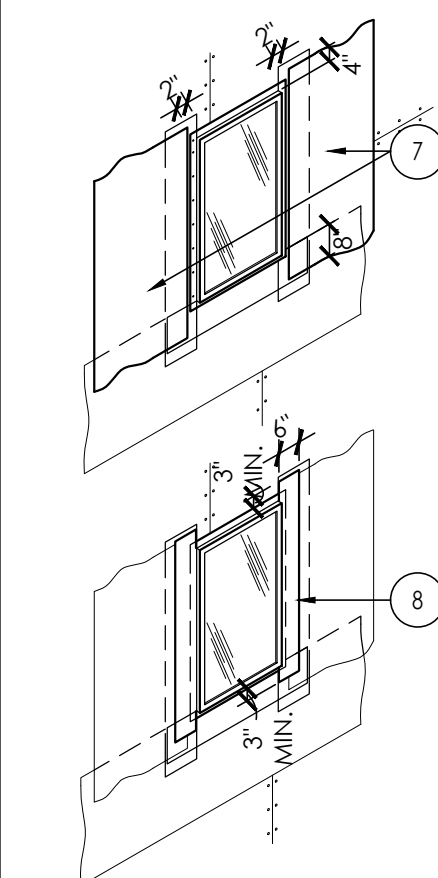

7 BLEEDER STRIPS AT JAMBS:
INSTALL ONE COURSE OF WEATHER-RESISTIVE BARRIER VERTICALLY AT JAMBS. OFFSET EDGE OF WEATHER-RESISTIVE BARRIER 2" FROM ROUGH OPENING.

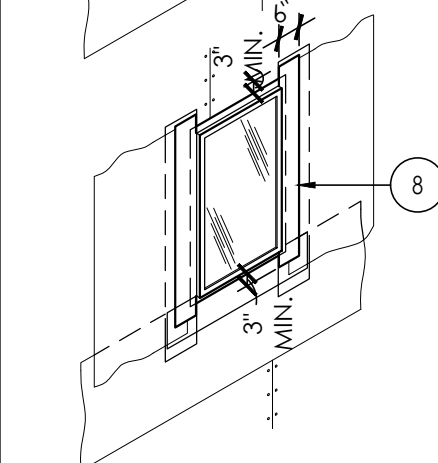

8 SELF-ADHESIVE JAMB FLASHING:
WIPE CLEAN NAILING FLANGE AND BASE FLASHING. APPLY 6" WIDE SELF-ADHESIVE JAMB FLASHING (FORTIFIBER "MOISTOP FORTIFLASH") OVER NAILING FLANGE. APPLY FIRM PRESSURE WITH A ROLLER ALONG ENTIRE SELF-ADHESIVE STRIP TO ENSURE A CONTINUOUS SEAL.

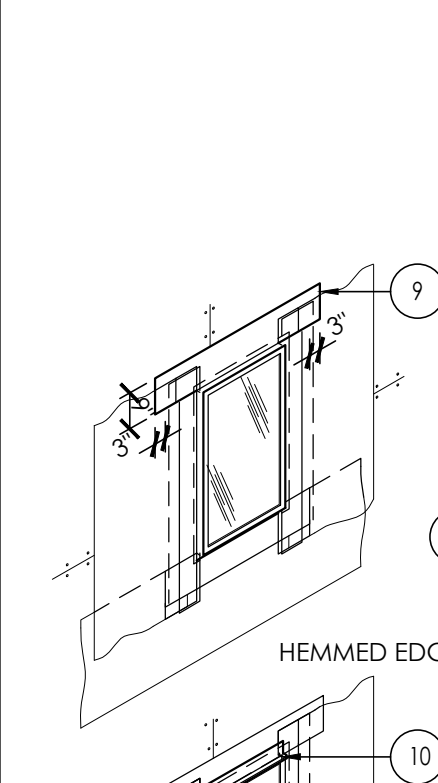

9 SELF-ADHESIVE HEAD MEMBRANE FLASHING:
WIPE CLEAN THE WINDOW FLANGE, PREVIOUS FLASHING LAYERS AND SUBSTRATE. APPLY 9" WIDE SELF-ADHESIVE HEAD FLASHING (FORTIFIBER "MOISTOP EZ-SEAL") OVER THE WINDOW FLANGE, BASE FLASHING AND SELF-ADHESIVE JAMB FLASHING. USING A ROLLER, APPLY FIRM PRESSURE ALONG THE ENTIRE SELF-ADHESIVE STRIP TO ENSURE A CONTINUOUS SEAL.

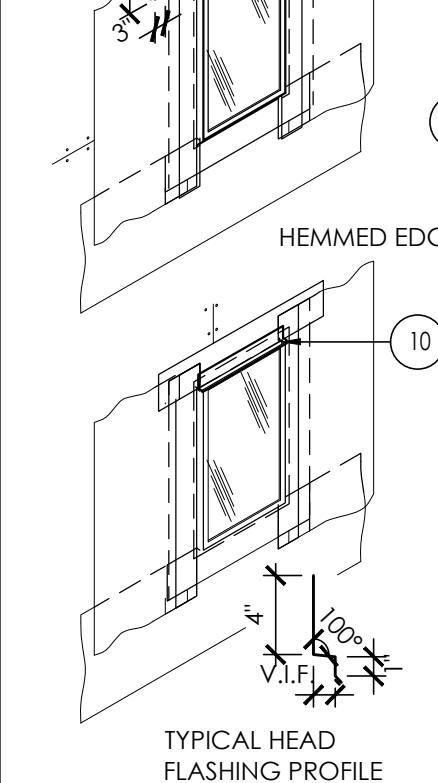

10 TYPICAL HEAD FLASHING PROFILE:
PROVIDE END DAM AT BOTH ENDS OF HEAD FLASHING (SEE WINDOW HEAD DETAIL).

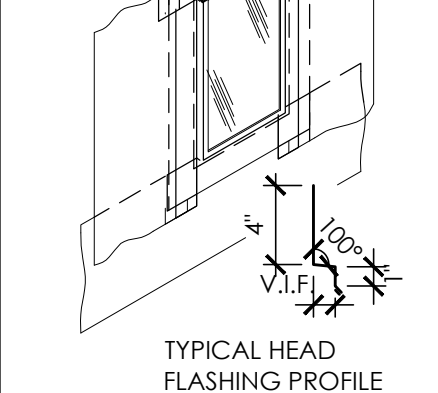

METAL SIDING APPLICATION:
APPLY METAL FLASHING DIRECTLY ABOVE WINDOW. EXTEND FLASHING BEYOND WINDOW FRAME 3/8" EACH SIDE, OR THE MINIMUM REQUIRED TO COVER 1/2" SEALANT JOINT.

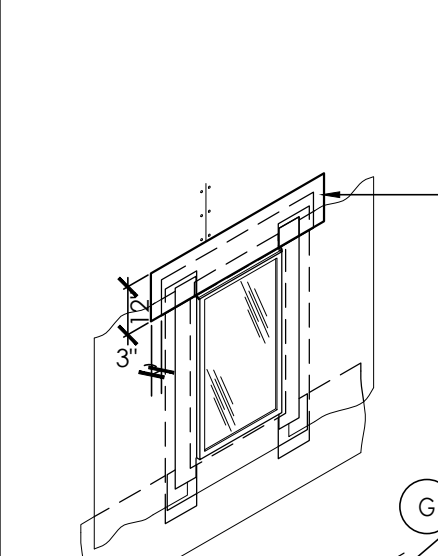

11 WATERPROOF HEAD FLASHING MEMBRANE:
INSTALL MEMBRANE (FORTIFIBER "FORTIFLASH") OVER METAL HEAD FLASHING. APPLY FIRM PRESSURE WITH A ROLLER ALONG THE ENTIRE SELF-ADHESIVE STRIP TO ENSURE A CONTINUOUS SEAL. FASTEN AT CORNERS AND MIDPOINT.

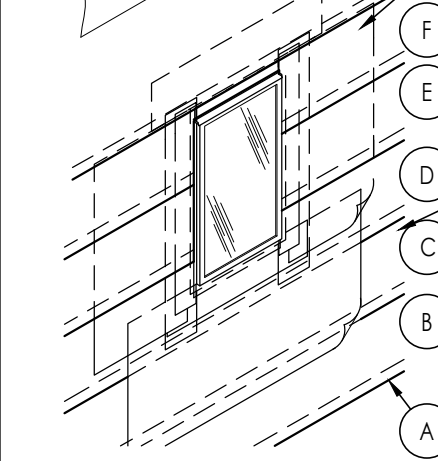

12 WEATHER-RESISTIVE BARRIER:
START AT THE BOTTOM OF THE WALL. LAY WEATHER-RESISTIVE BARRIER UP THE WALL, OVERLAPPING 1/2 ROLL + 4" MIN. HORIZ. AND 6" VERTICAL IN WEATHERBOARD FASHION. MAKE SURE THAT COURSE 'C' AND 'D' ARE PLACED UNDER THE SILL STRIP FLASHING AND JAMB FLASHING. ALIGN VERTICAL EDGE OF W.R.B. WITH SIDES OF HEAD FLASHING (LETTERS REFER TO ORDER OF INSTALLATION)

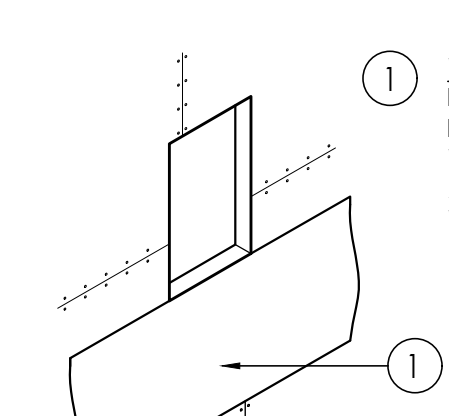

1 WEATHER-RESISTIVE BARRIER MATERIAL AT SILL:
INSTALL ONE COURSE OF WEATHER-RESISTIVE BARRIER AT SILL. FASTEN ONLY THE TOP OF WEATHER-RESISTIVE BARRIER TO SUBSTRATE, TO ALLOW (FOLLOWING) LOWER COURSE OF WEATHER RESISTIVE BARRIER TO GO UNDERNEATH.

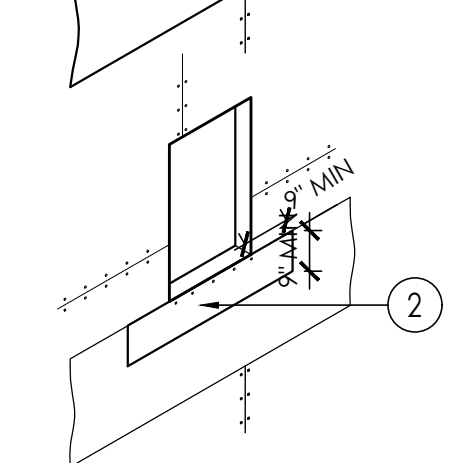

2 BASE FLASHING - SILL:
INSTALL WATER-RESISTANT BASE FLASHING (FORTIFIBER "NEXT") AT SILL, ON TOP OF WEATHER-RESISTIVE BARRIER.

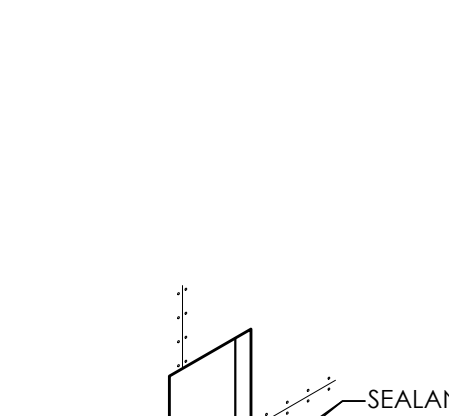

3 CORNER SHIELD:
FASTEN PRE-FORMED CORNER SHIELDS IN BEAD OF SEALANT AT JAMB TO FRAMING. CUT TO FIT TIGHT TO EXISTING LINER. DO NOT NAIL THROUGH SILL.

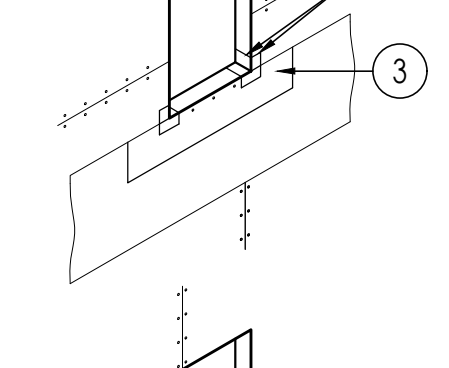

4 SILL WRAP:
INSTALL SELF-ADHESIVE SILL WRAP FLASHING (FORTIFIBER "FORTIFLASH") AT SILL, ON TOP OF BASE FLASHING AND CORNER SHIELDS. INSTALL UP TO LINER.

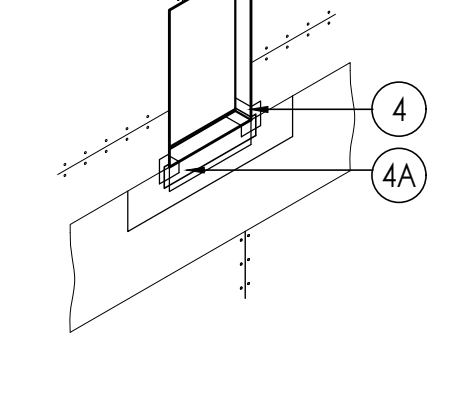

4A SILL PAN:
METAL SILL PAN WITH VERTICAL INTERIOR LIP OVER SILL WRAP

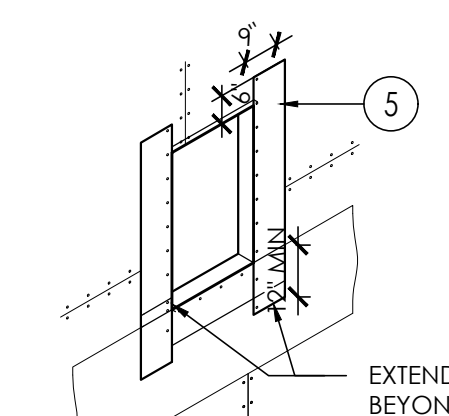

5 VERTICAL BASE FLASHING - JAMB:
INSTALL VERTICAL BASE FLASHING (FORTIFIBER "MOISTOP") OVER SILL FLASHING.

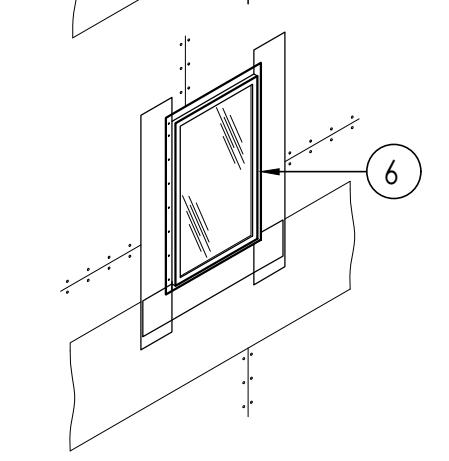

6 WINDOW FLANGE W/ SILICONE SEALANT:
APPLY CONTINUOUS BEAD OF SILICONE SEALANT (ASTM C-920 TYPE "S" GRADE N.S. CLASS 2S) ALONG TOP, SIDES AND BOTTOM OF WINDOW FLANGE. DO NOT NAIL AT WINDOW HEAD. INSTALL WINDOW IN OPENING PER MANUFACTURER'S SPECIFICATIONS.

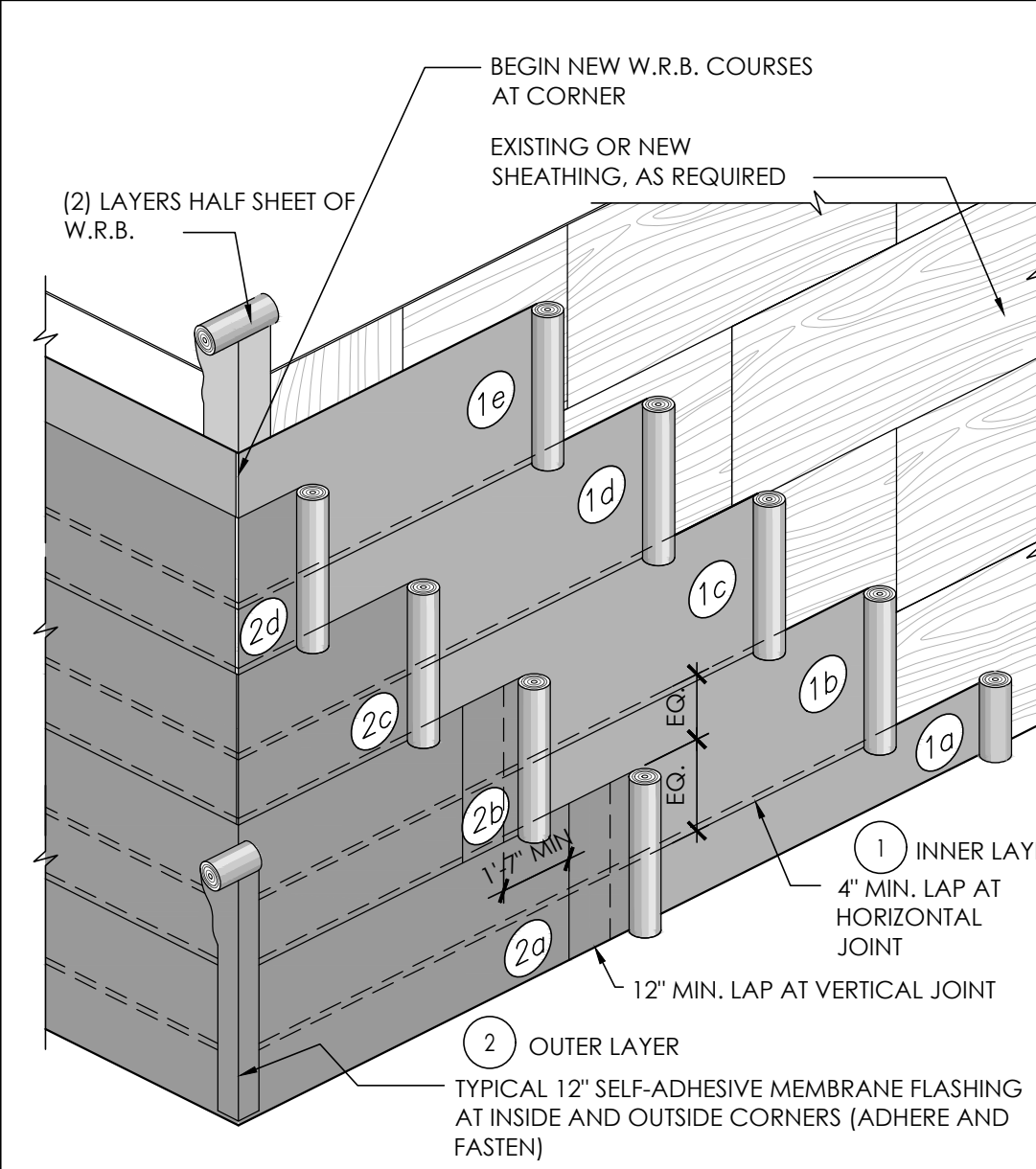

TYPICAL SEQUENCING OF WEATHER RESISTIVE MEMBRANE PRIOR TO INSTALLATION OF EXTERIOR FINISH MATERIAL

A1 WEATHER RESISTIVE BARRIER

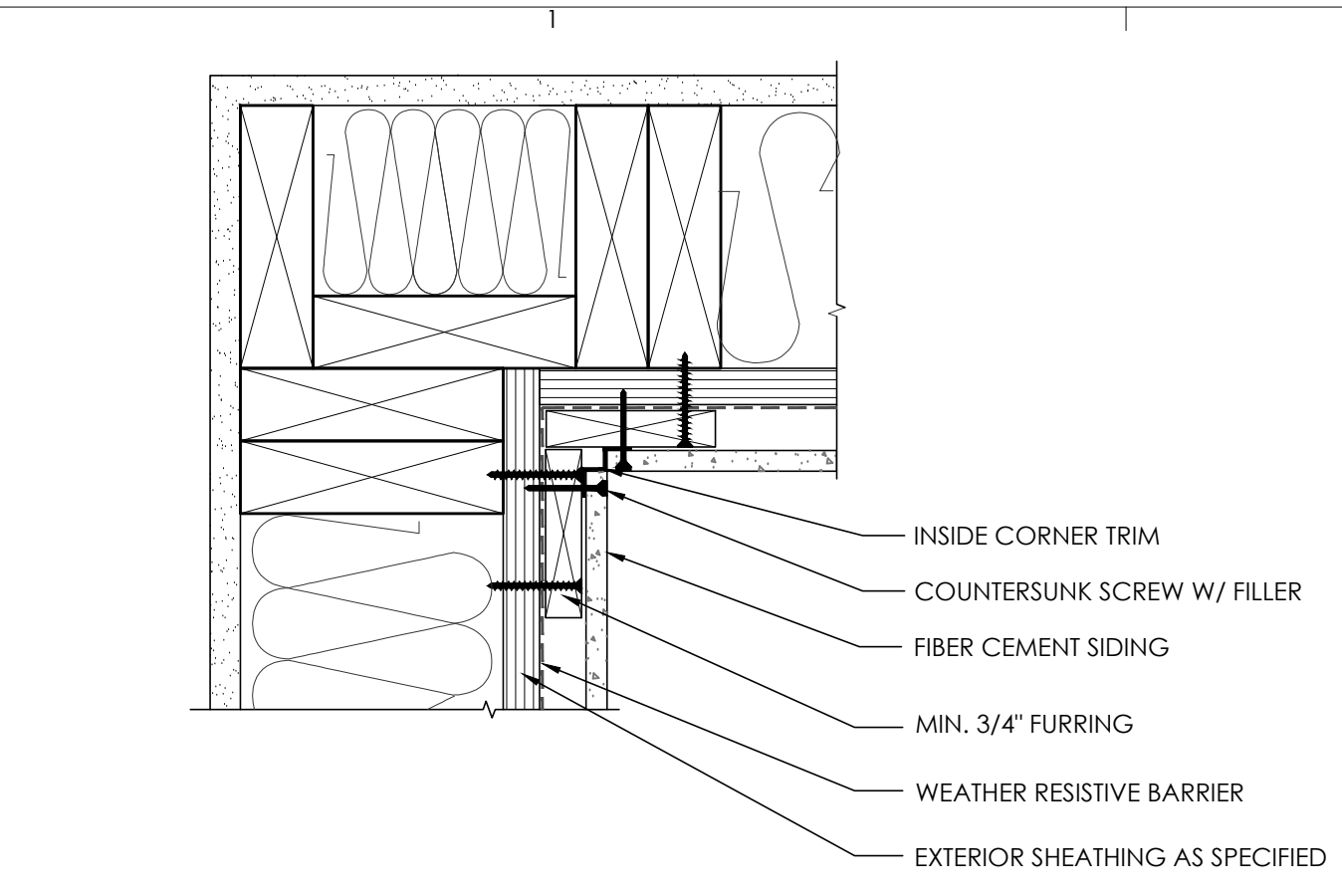
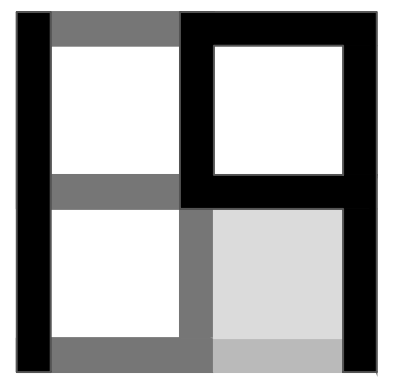

D1 PLAN DETAIL AT INSIDE CORNER TRIM
SCALE: 3" = 1'-0"

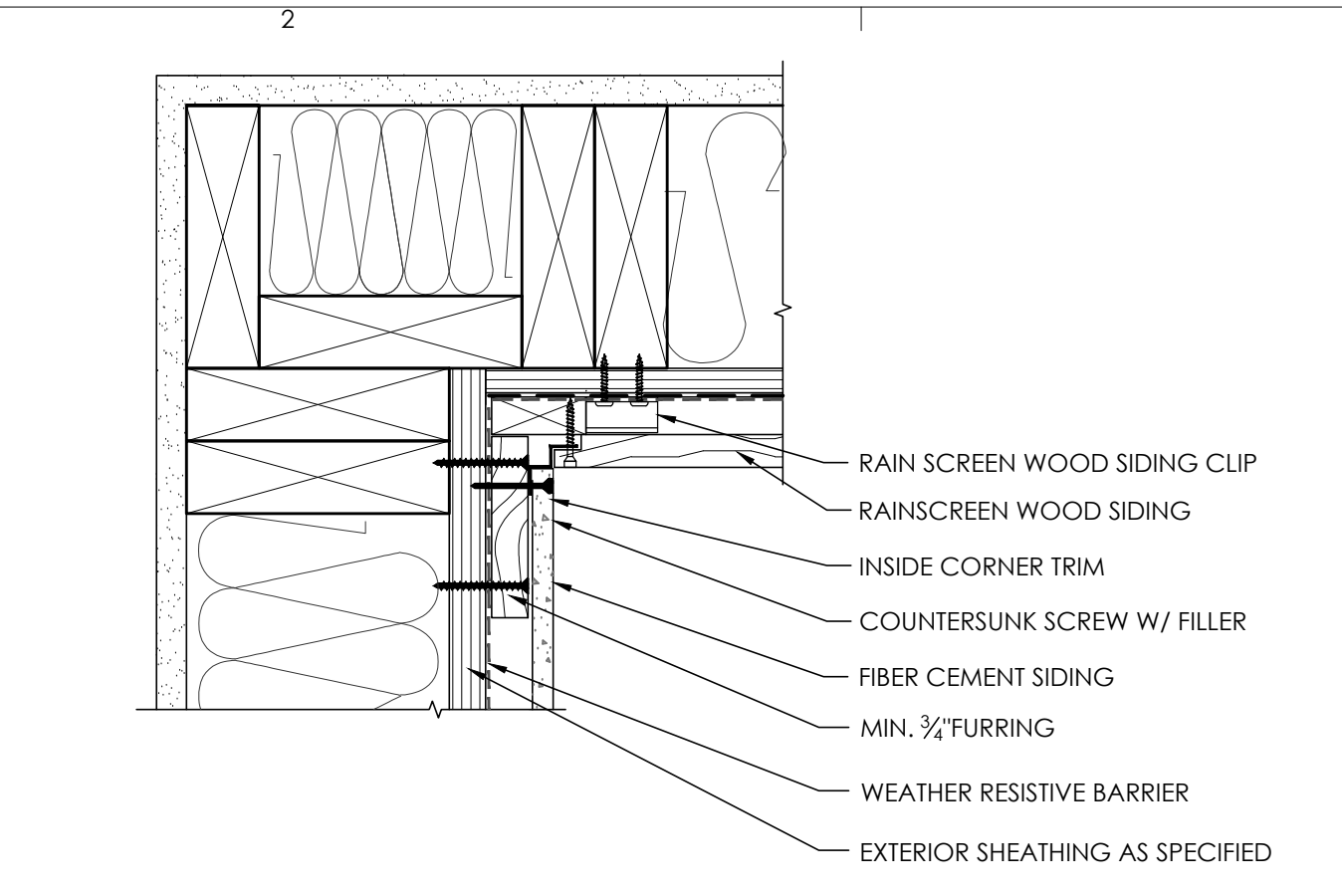

D2 INSIDE CORNER - FIBER CEMENT TO WOOD
SCALE: 3" = 1'-0"

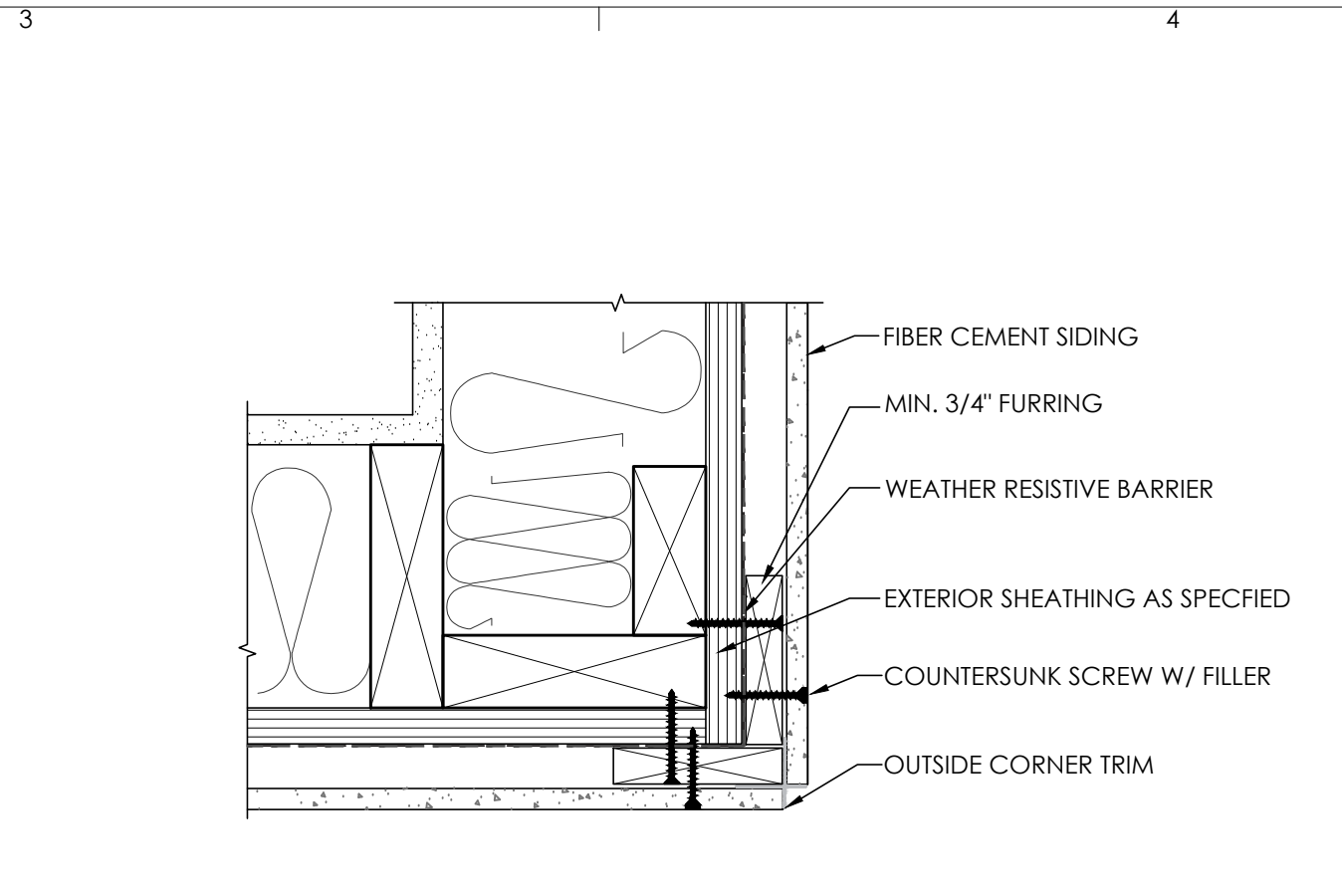

D3 PLAN DETAIL AT OUTSIDE CORNER TRIM
SCALE: 3" = 1'-0"

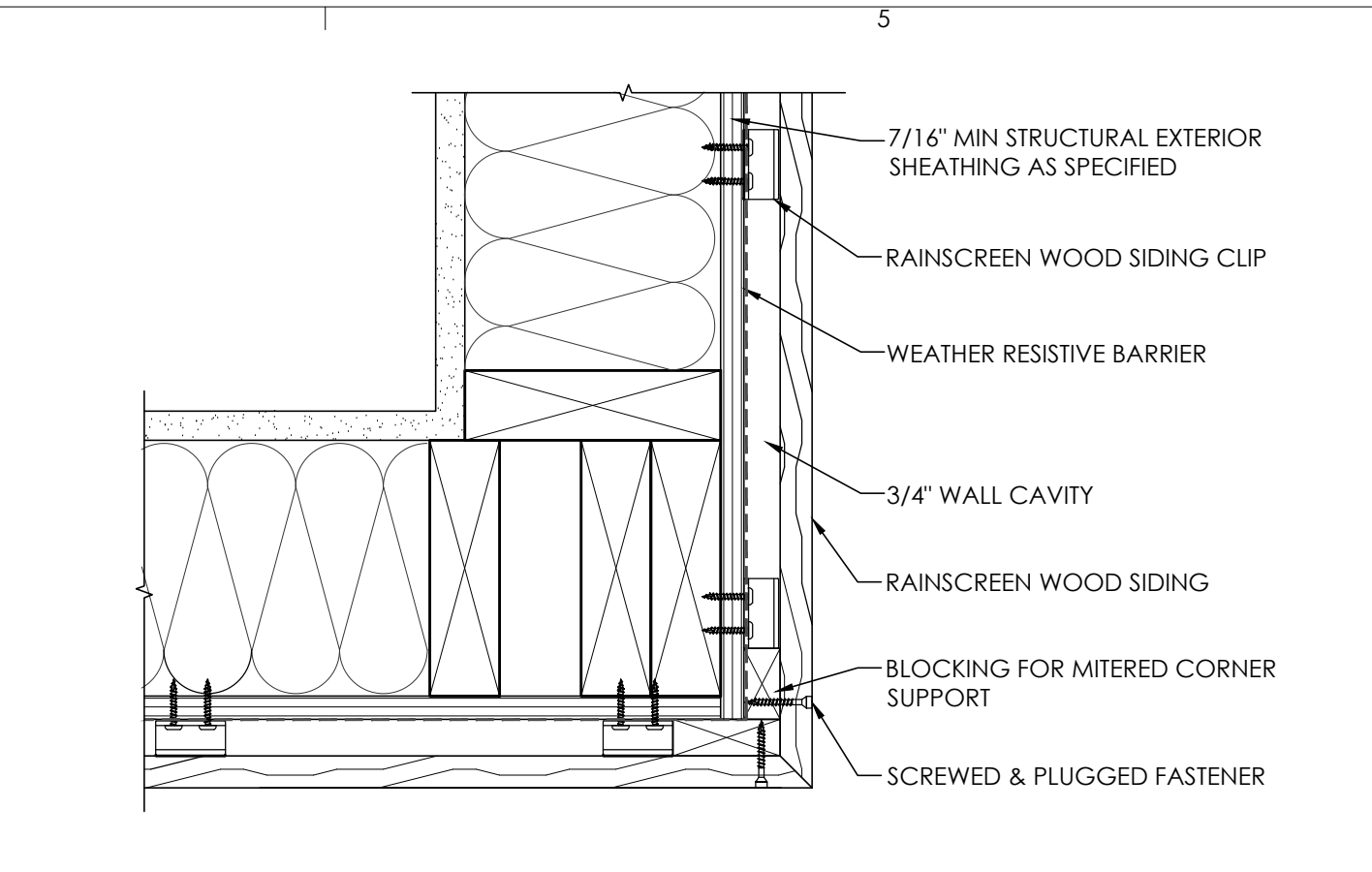

D5 OUTSIDE CORNER AT WOOD SIDING
SCALE: 3" = 1'-0"

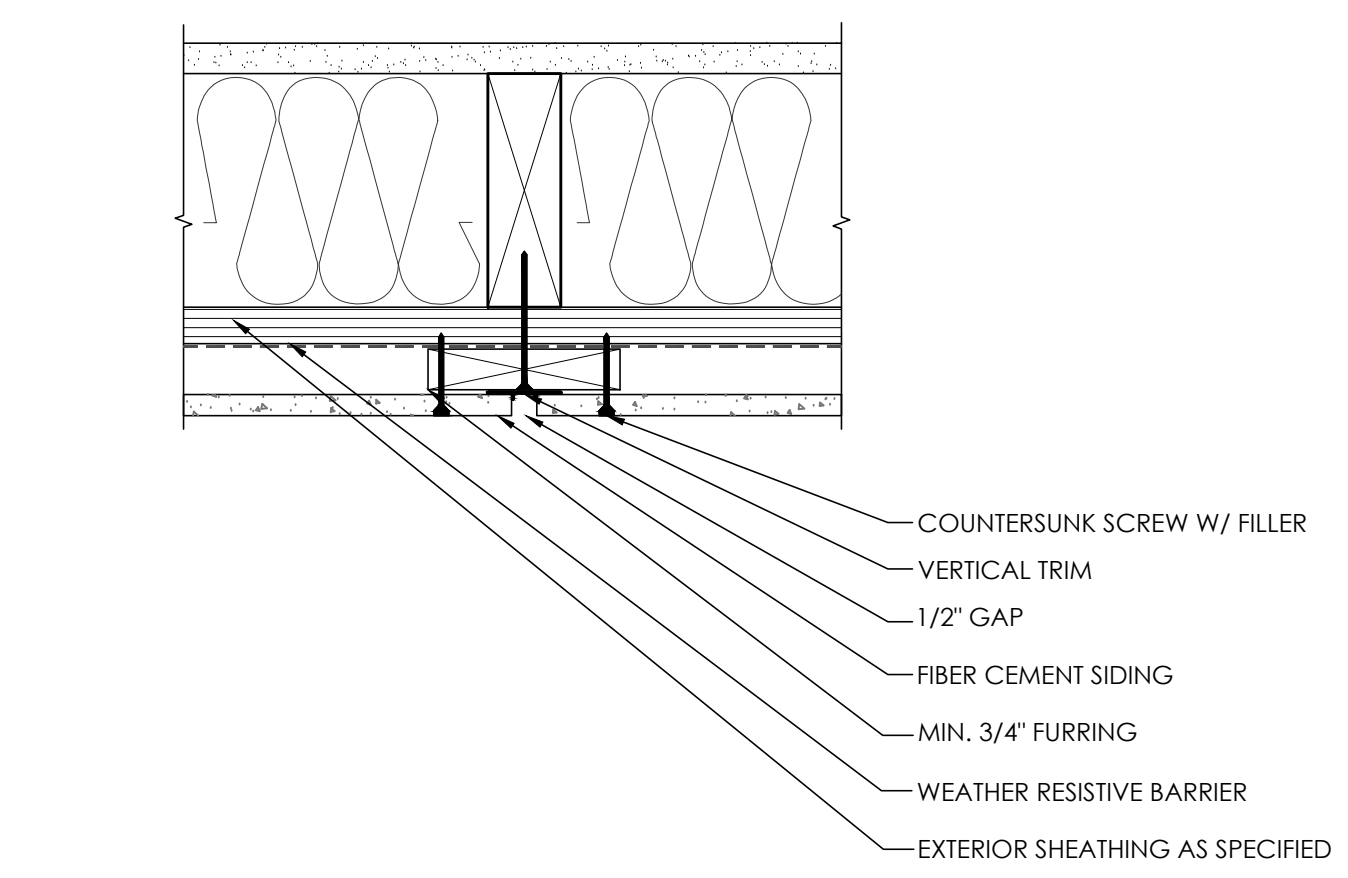

C1 PANEL SECTION W/ VERTICAL TRIM
SCALE: 3" = 1'-0"

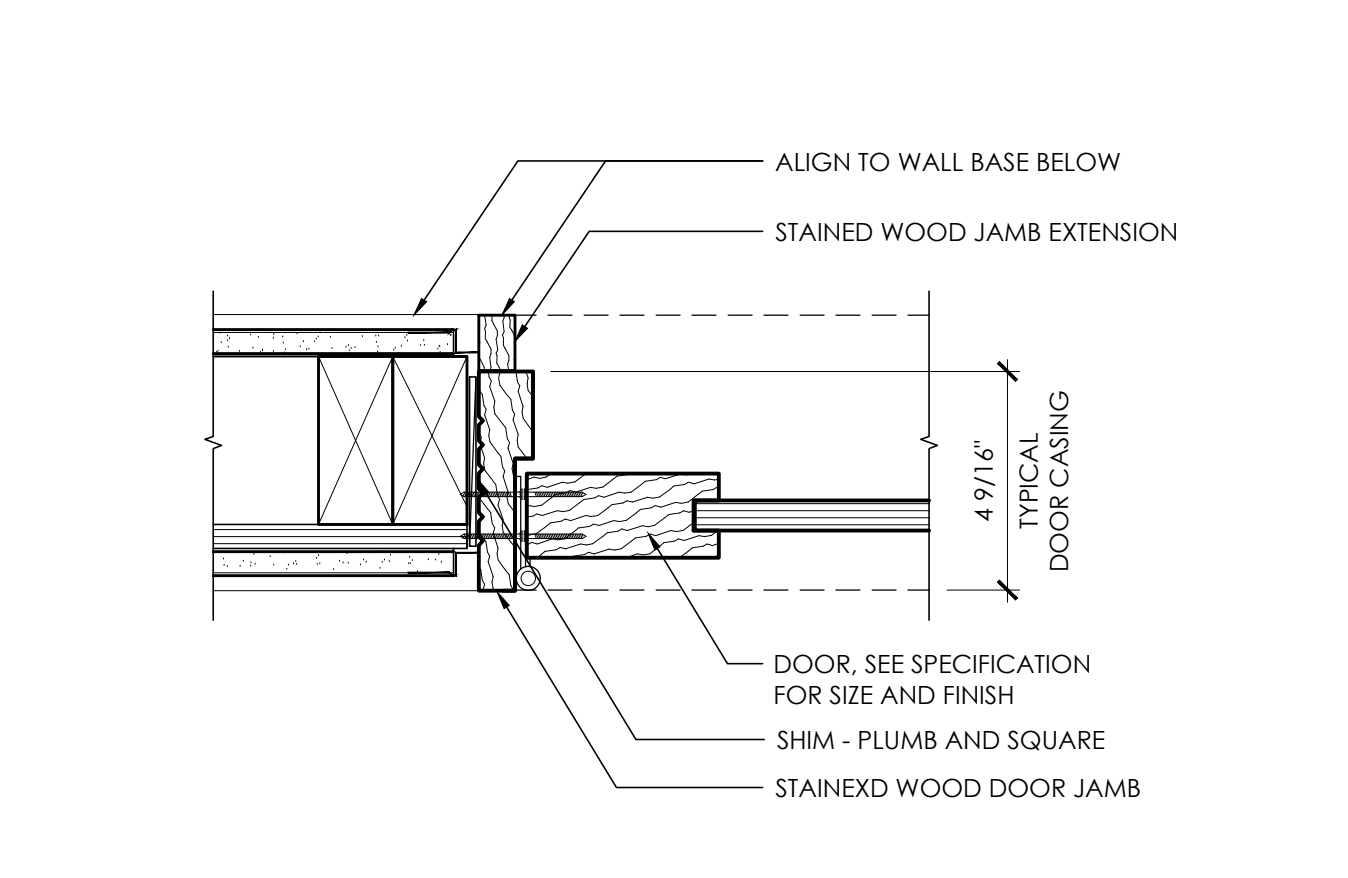

C2 INTERIOR DOOR JAMB
SCALE: 3" = 1'-0"

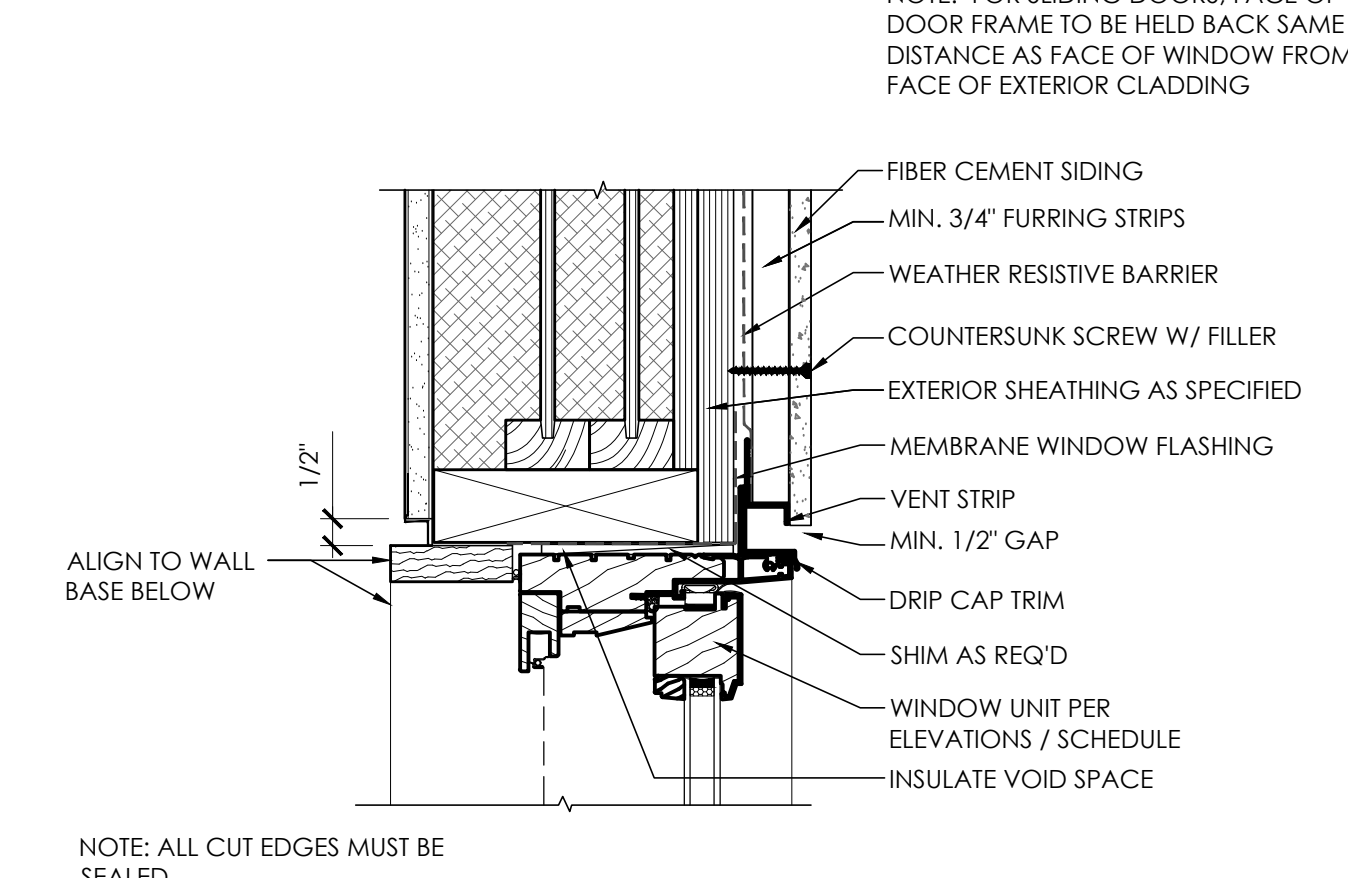

C3 WINDOW HEAD AT SIDING - DOOR HEAD SIM.
SCALE: 3" = 1'-0"

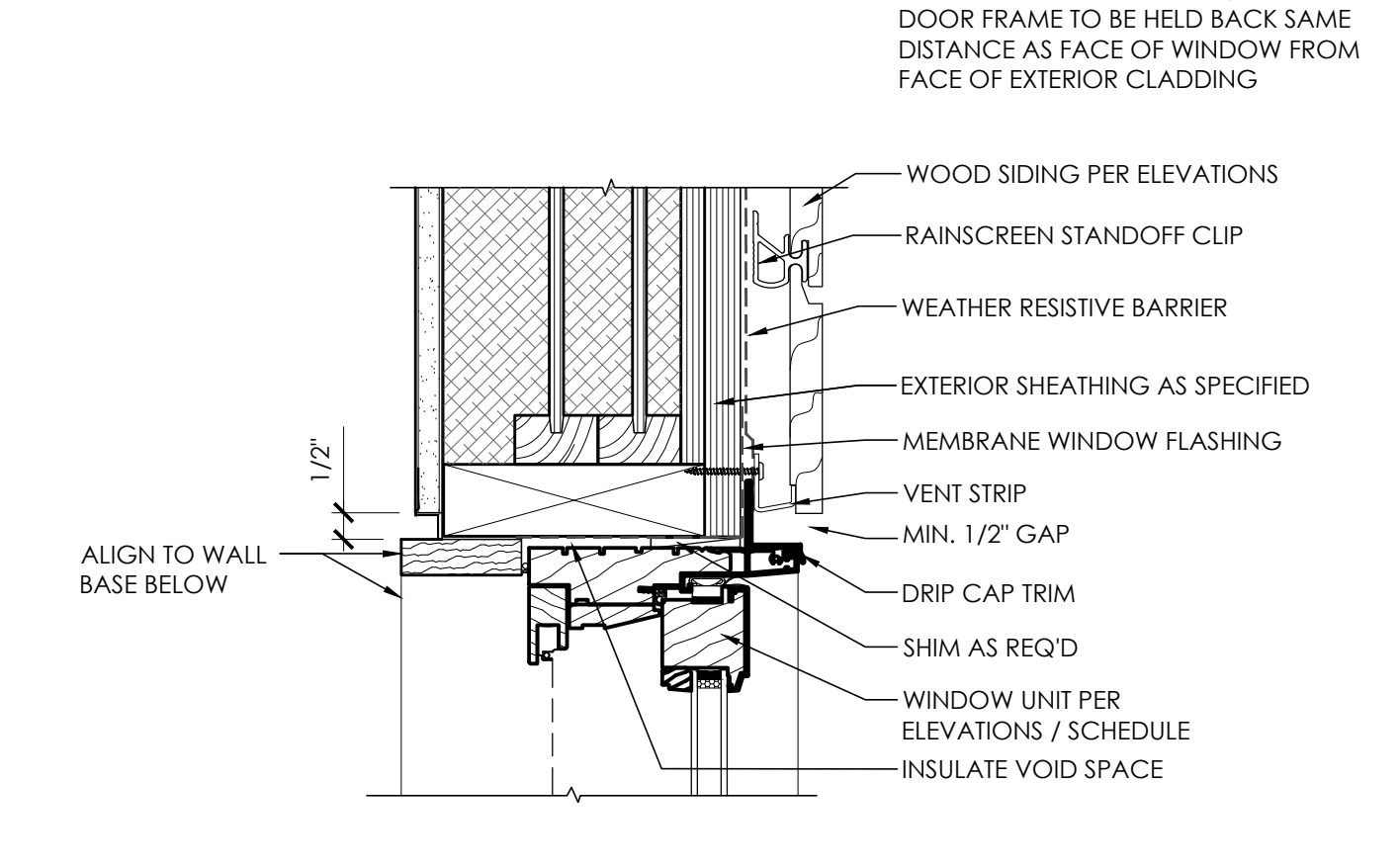

C5 WINDOW HEAD AT WOOD SIDING - DOOR HEAD SIM.
SCALE: 3" = 1'-0"

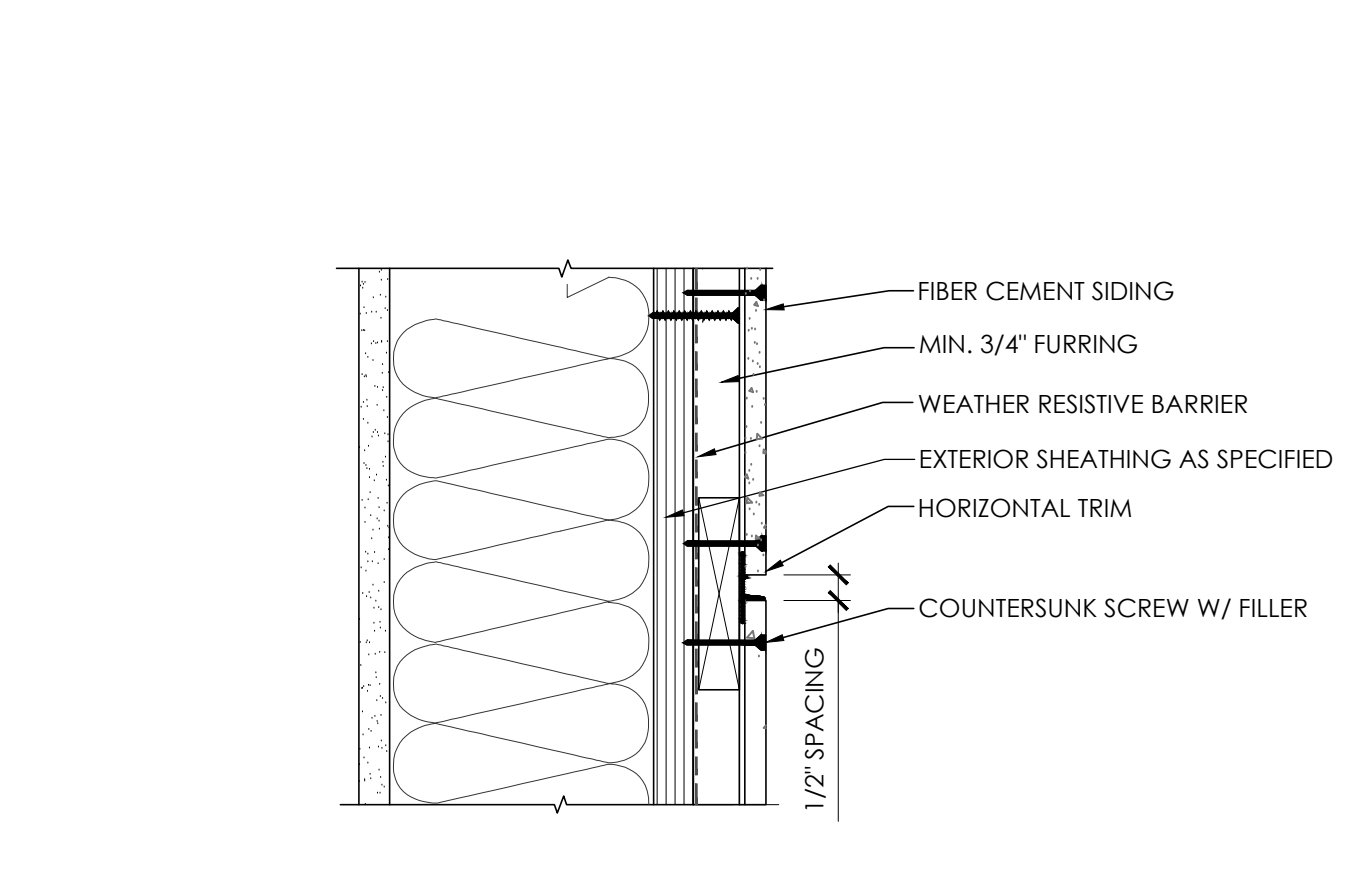

B1 PANEL SECTION W/ HORIZONTAL TRIM
SCALE: 3" = 1'-0"

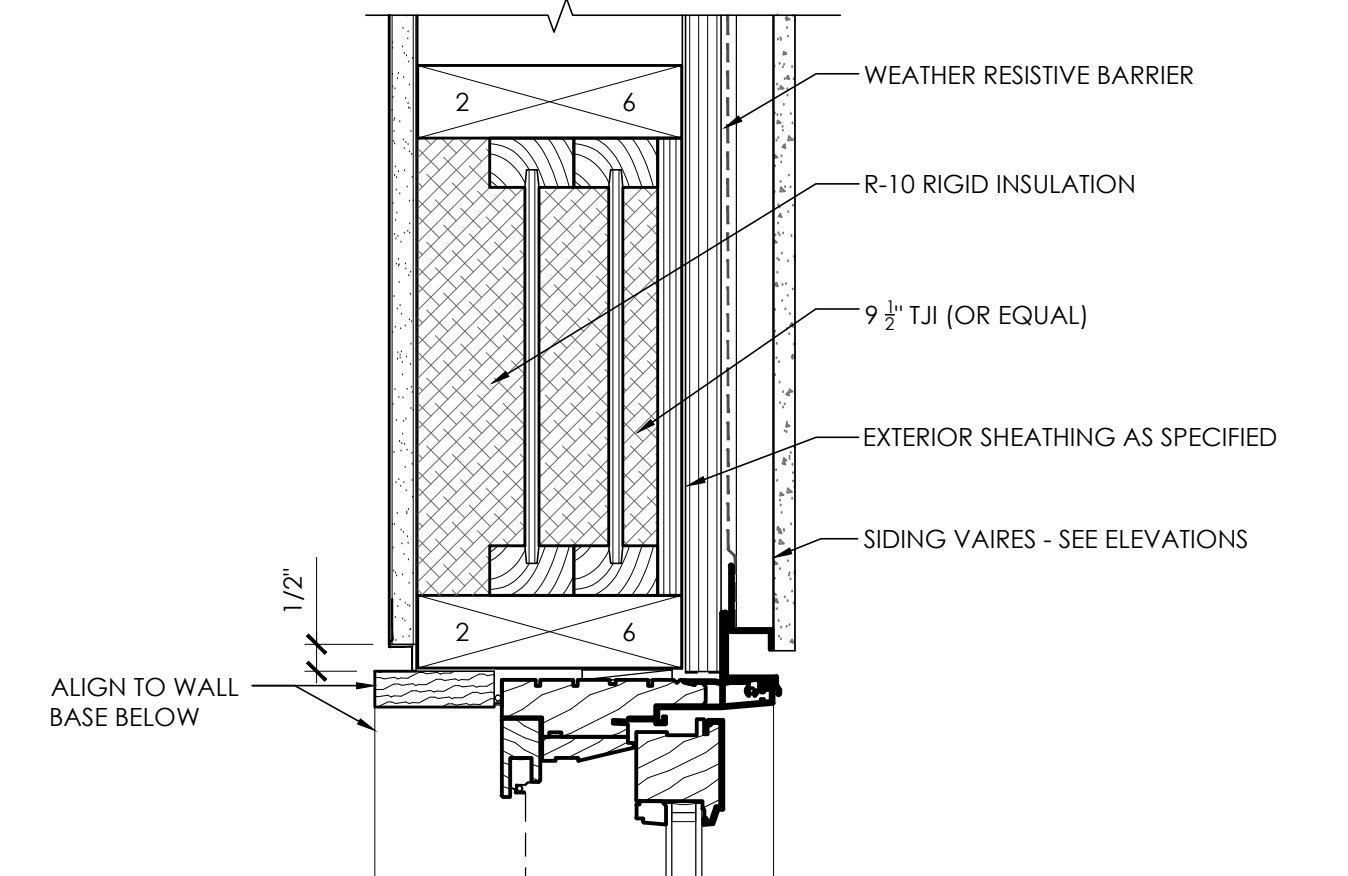

B2 TYPICAL WINDOW/DOOR HEADER
SCALE: 3" = 1'-0" CONTRACTOR OPTION

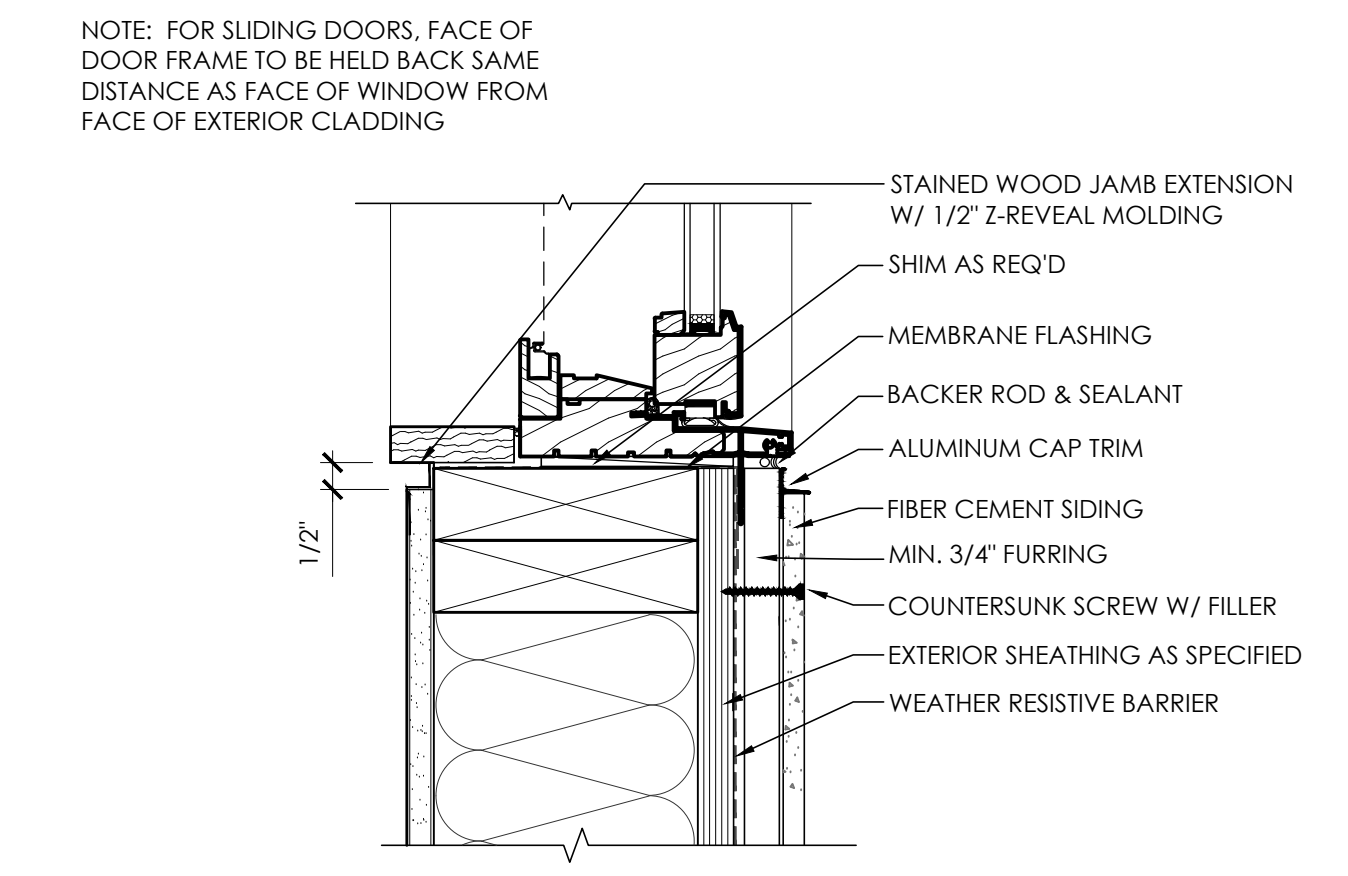

B3 WINDOW SILL AT SIDING
SCALE: 3" = 1'-0"

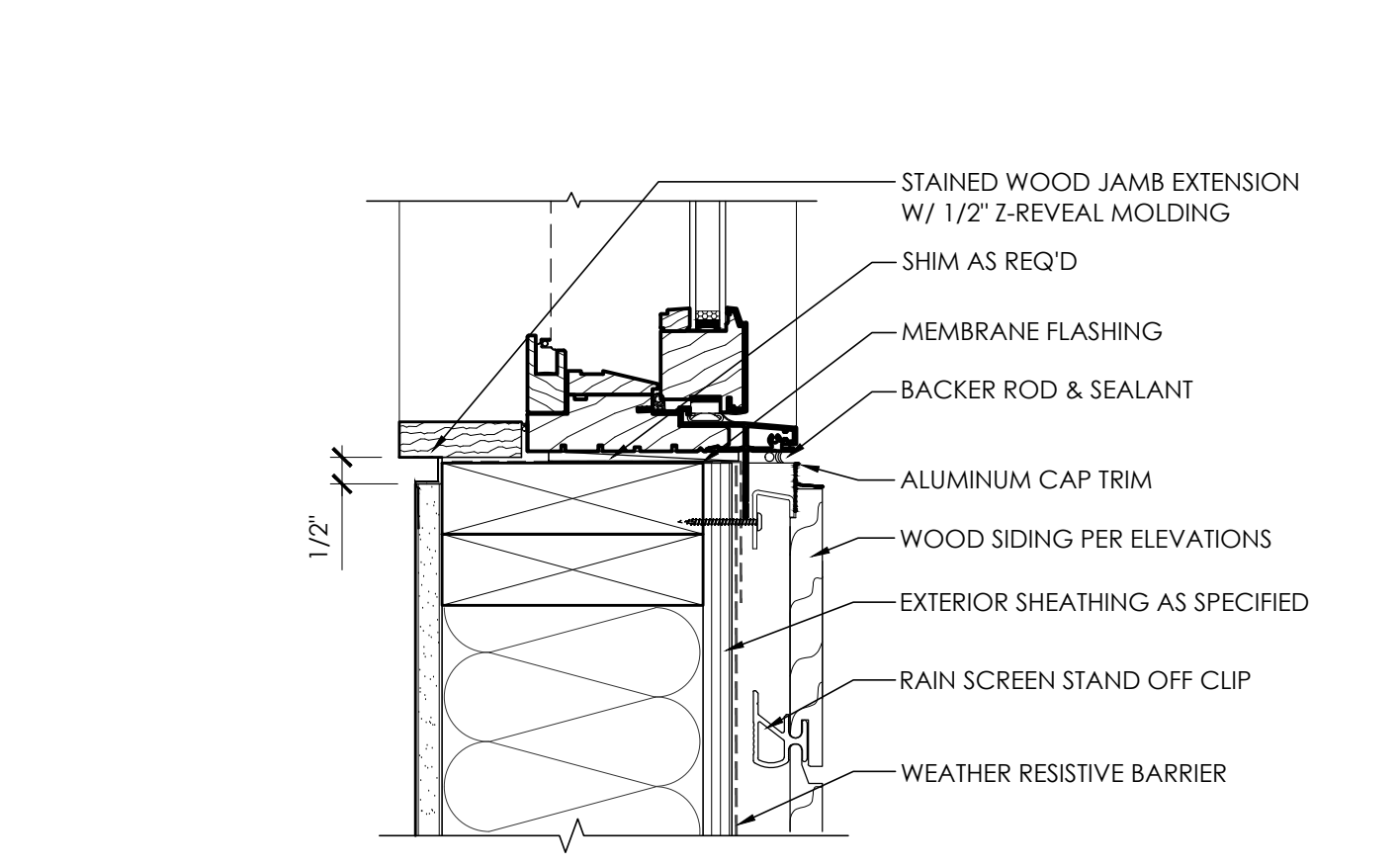

B5 WINDOW SILL AT WOOD SIDING
SCALE: 3" = 1'-0"

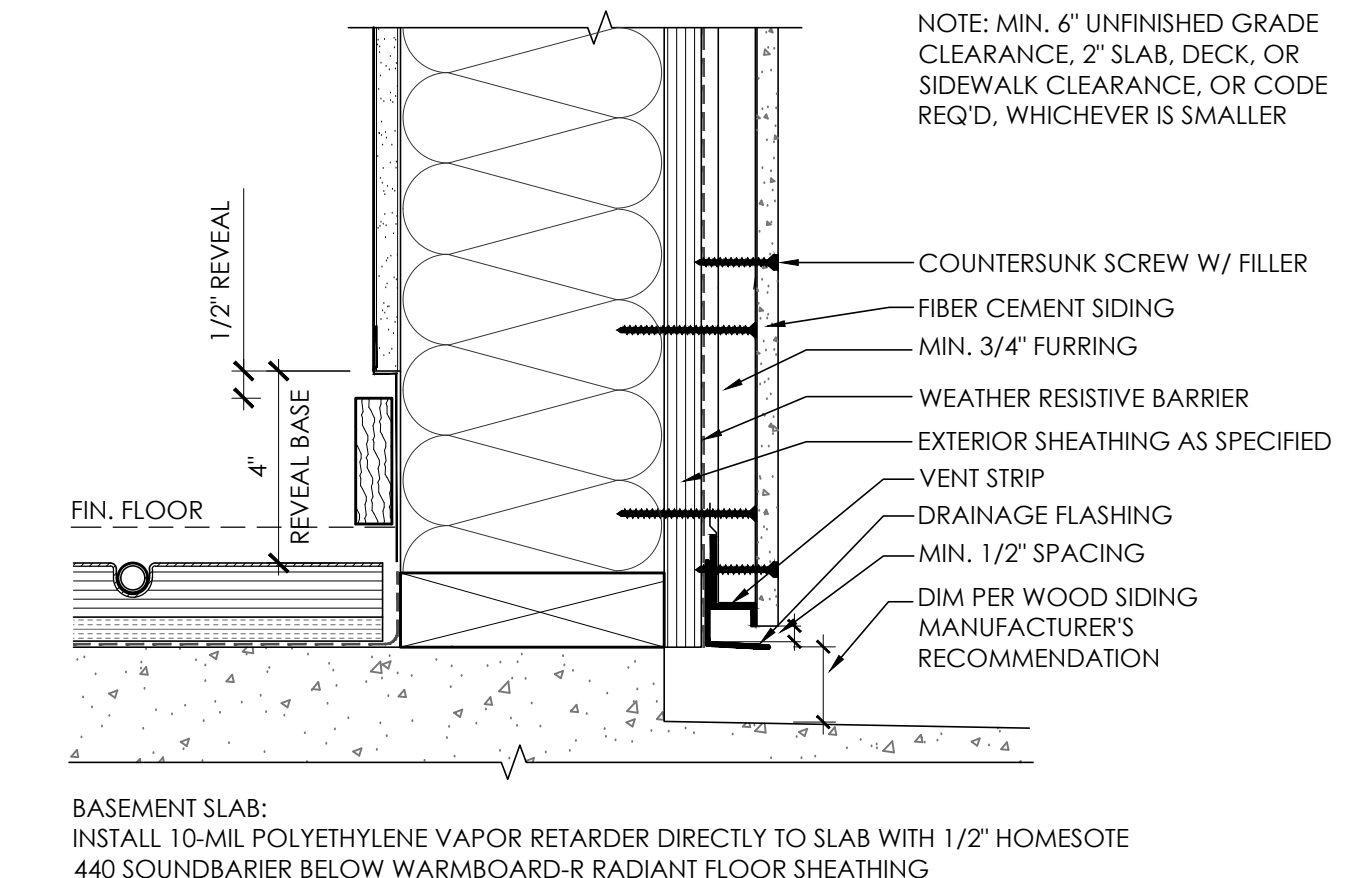

A1 FOUNDATION DETAIL
SCALE: 3" = 1'-0"

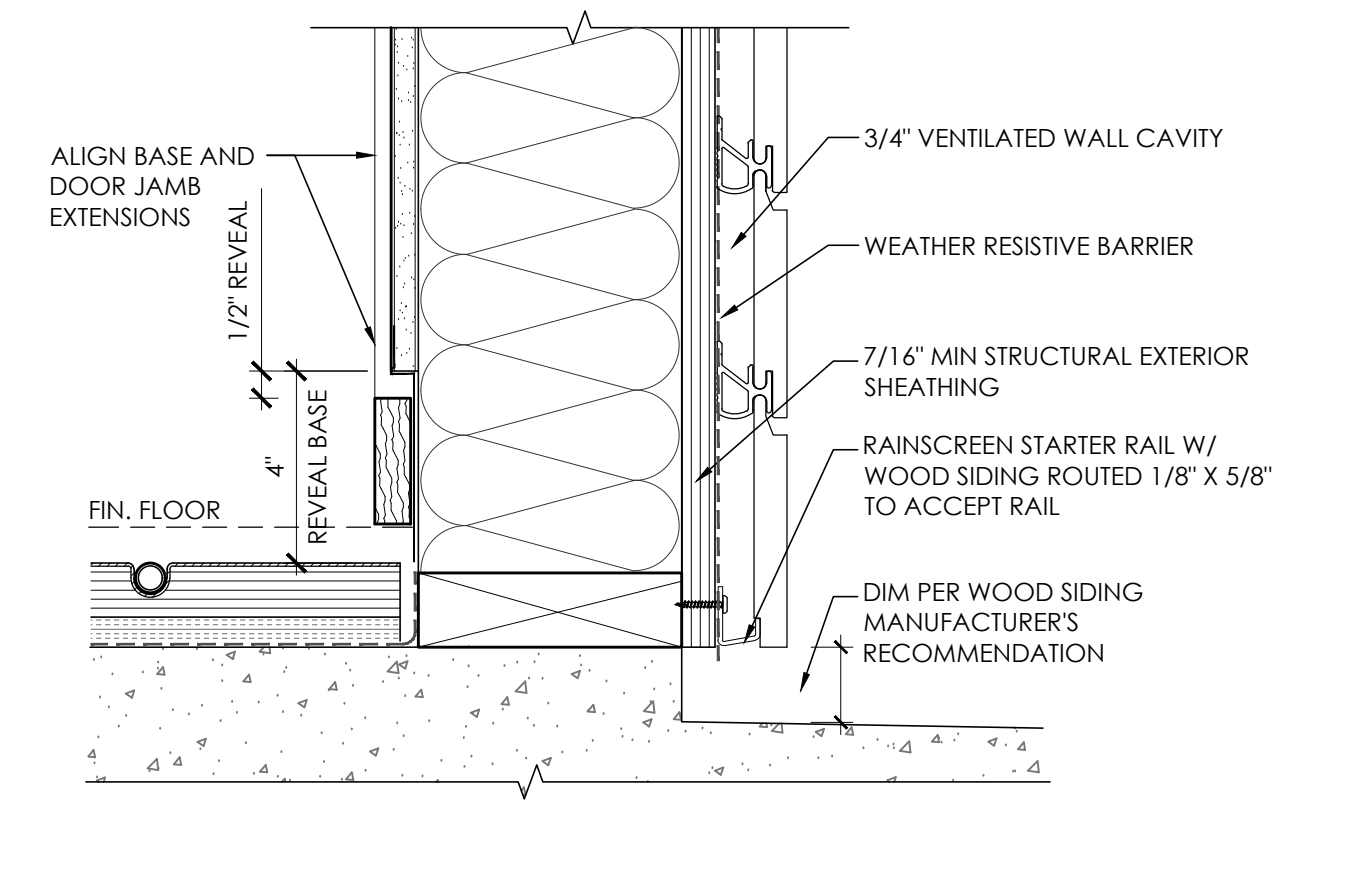

A2 FOUNDATION DETAIL
SCALE: 3" = 1'-0"

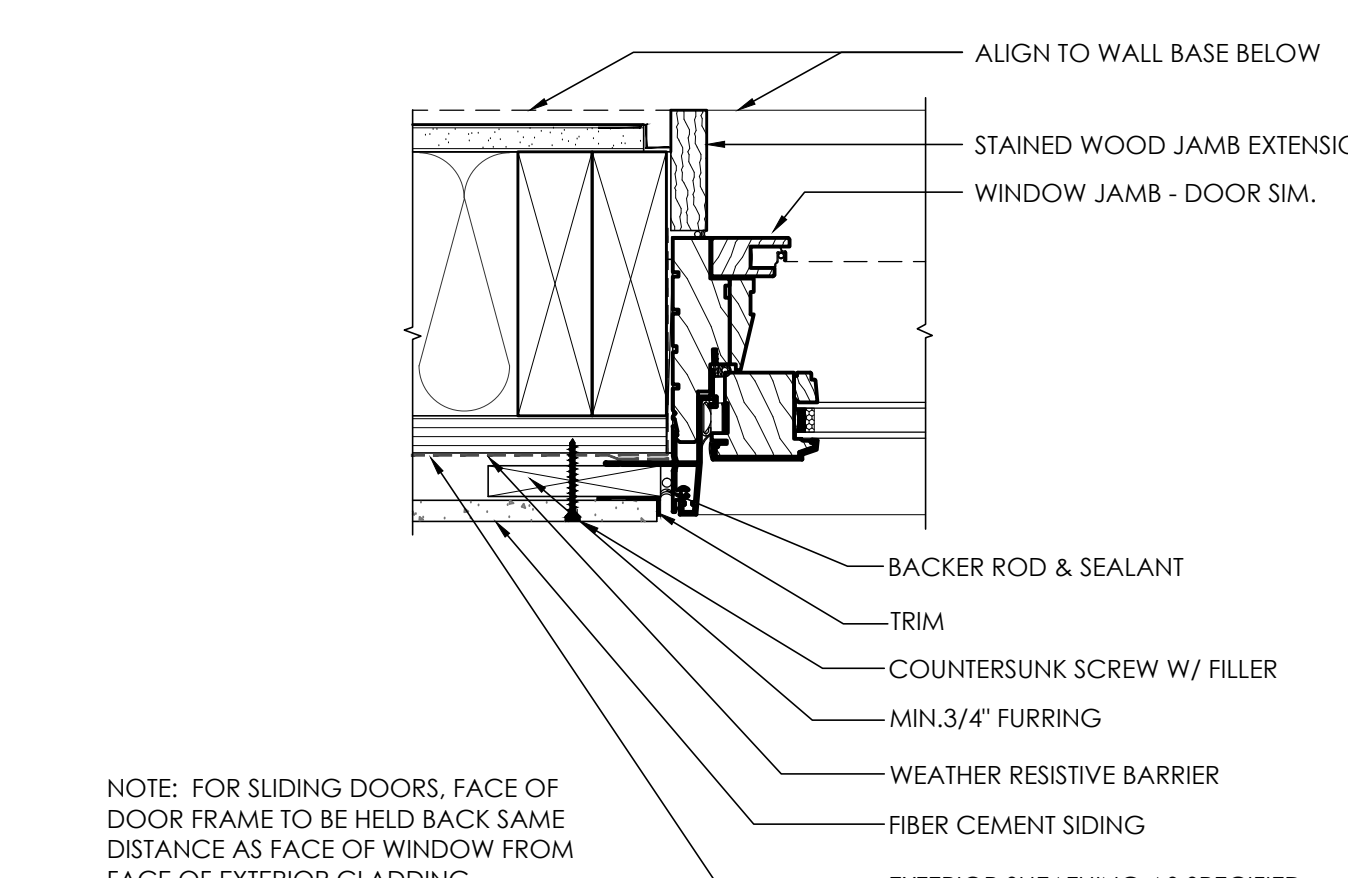

A3 WINDOW JAMB AT SIDING - DOOR JAMB SIM.
SCALE: 3" = 1'-0"

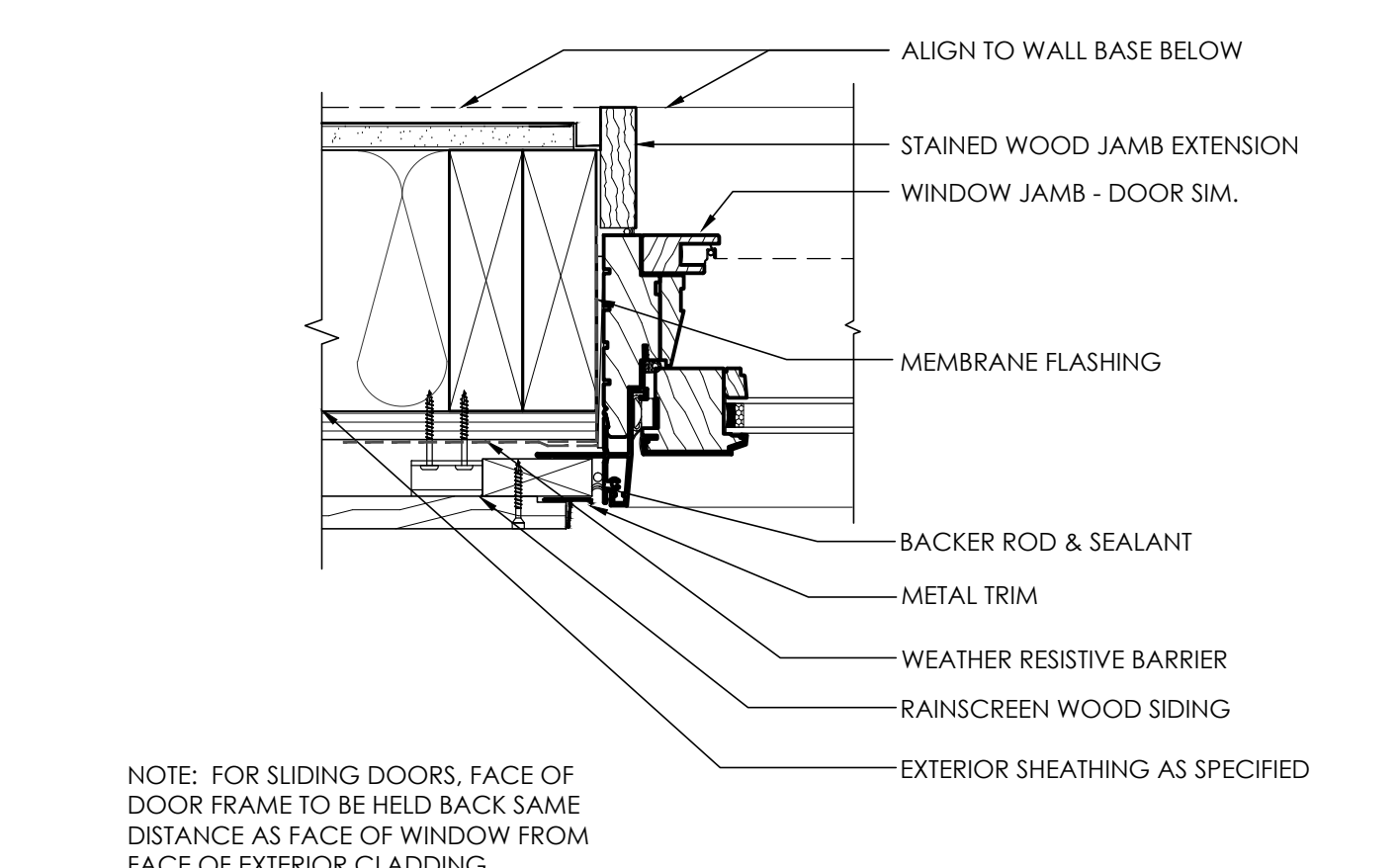

A5 WINDOW JAMB AT WOOD SIDING - DOOR JAMB SIM.
SCALE: 3" = 1'-0"

CONSULTANT: _____

PROFESSIONAL SEAL: _____



PROJECT: _____

a project for:
Barcelo homes
PO BOX 1733 AUBURN, WA 98071
Phone: (206) 724-1072

EAST MERCER RESIDENCE

4634 EAST MERCER WAY
MERCER ISLAND, WA 98040

SHEET ISSUE:

| | |
|------------|--------------------|
| 6/24/2015 | PERMIT SUBMITTAL |
| 8/29/2016 | PERMIT APPROVED |
| 6/05/2017 | REVISION TO PERMIT |
| 05/08/2018 | REVISION TO PERMIT |

MARK DATE DESCRIPTION

MUNICIPALITY REVIEW: _____

PROJECT # MERCER ISLAND 15 - 015

SHEET TITLE: _____

EXTERIOR DETAILS - CLADDING

PROJECT NO.: 20140904

DATE ISSUED: 05/08/2018

SHEET NUMBER: _____

A8.02
Exhibit 5

| OPENING SCHEDULE - LEVEL 1 - INTERIOR DOORS | | | | | | | | | | | |
|---|------------|-------|-------------------|-------------|---|-------|---------|----------|----------|------|---------|
| MARKER | DIMENSION | | FIRE RATING (MIN) | HARDWARE | TYPE | FRAME | | | DETAILS | | REMARKS |
| | W | H | | | | TYPE | FINISH | HEAD | JAMB | SILL | |
| 100A | 3'-0" | 8'-0" | 20 MIN | TBD | PASSAGE W/ SELF CLOSING HINGES | WOOD | STAINED | A3/A9.01 | A3/A9.01 | N/A | |
| 100B | 3'-0" | 8'-0" | 20 MIN | CALL BUTTON | ELEVATOR W/ SELF CLOSING HINGES | | | | | | |
| 100C | 2'-6" | | | | PASSAGE | | | | | | |
| 101 | 2'-6" | | | | PRIVACY | | | | | | |
| 102A | 2'-6" | | | | PRIVACY | | | | | | |
| 102C | PAIR 2'-0" | | | | PASSAGE / CLOSET | | | | | | |
| 103A | 12'-0" | | | | SLIDING POCKET | | | | | | |
| 103D | PAIR 2'-6" | | | | PASSAGE / CLOSET | | | | | | |
| 104A | 3'-0" | 8'-0" | TEMPERED | | PIVOT GLASS DOOR / 1/2" LAMINATED GLASS | GLASS | CLEAR | N/A | N/A | N/A | |
| 105 | 2'-6" | 8'-0" | | | PRIVACY | WOOD | STAINED | A3/A9.01 | A3/A9.01 | N/A | |
| 106 | 3'-0" | | 20 MIN | | PASSAGE W/ SELF CLOSING HINGES | | | | | | |
| 109 | 2'-6" | | | | PASSAGE | | | | | | |
| 113C | PAIR 2'-6" | | 20 MIN. | | PASSAGE W/ SELF CLOSING HINGES | | | | | | |

| OPENING SCHEDULE - LEVEL 1 - EXTERIOR WINDOWS | | | | | | | | | | |
|---|----------------|----------------|----------------------------|----------------|-----------|--------|---------------|---------------|---------------|---|
| MARKER | DIMENSION | | HEAD HEIGHT ABOVE SUBFLOOR | TYPE | FRAME | | | DETAILS | | REMARKS |
| | W | H | | | TYPE | FINISH | HEAD | JAMB | SILL | |
| 100 | SEE ELEVATIONS | SEE ELEVATIONS | SEE ELEVATIONS | GANGED PICTURE | CLAD WOOD | BRONZE | SEE SHT AB.02 | SEE SHT AB.02 | SEE SHT AB.02 | SAFETY GLAZING NOTED ON ELEVATIONS - TYP. |
| 101 | | | | PICTURE | | | | | | |
| 102 | | | | PICTURE | | | | | | |
| 103 | | | | PICTURE | | | | | | |
| 104 | | | | PICTURE | | | | | | |

| OPENING SCHEDULE - LEVEL 2 - INTERIOR DOORS | | | | | | | | | | | |
|---|------------|-------|-------------------|----------|------------------|-------|---------|----------|----------|------|---------|
| MARKER | DIMENSION | | FIRE RATING (MIN) | HARDWARE | TYPE | FRAME | | | DETAILS | | REMARKS |
| | W | H | | | | TYPE | FINISH | HEAD | JAMB | SILL | |
| 200B | PAIR 2'-6" | 8'-0" | | TBD | PASSAGE / CLOSET | WOOD | STAINED | A3/A9.01 | A3/A9.01 | N/A | |
| 203 | 4'-6" | | | | BARN SLIDER | | | | | | |
| 204B | 3'-0" | | | | PASSAGE | | | | | | |
| 204C | 3'-0" | | | | POCKET/PASSAGE | | | | | | |
| 204D | 3'-0" | | | | POCKET/PASSAGE | | | | | | |
| 206 | 3'-0" | | | | PASSAGE | | | | | | |
| 207A | 2'-4" | | | | PASSAGE / CLOSET | | | | | | |
| 207B | 3'-0" | | 20 MIN | | PASSAGE | | | | | | |
| 208 | 2'-4" | | | | PASSAGE / CLOSET | | | | | | |
| 209 | 2'-8" | | | | PRIVACY | | | | | | |
| 210B | PAIR 2'-4" | | | | PRIVACY | | | | | | |
| 211 | 2'-6" | | | | PRIVACY | | | | | | |

| OPENING SCHEDULE - LEVEL 1 - EXTERIOR DOORS | | | | | | | | | | | |
|---|----------------|----------------|-------------------|----------|------------------------------------|-----------|--------|---------------|---------------|---------|---------|
| MARKER | DIMENSION | | FIRE RATING (MIN) | HARDWARE | TYPE | FRAME | | | DETAILS | | REMARKS |
| | W | H | | | | TYPE | FINISH | HEAD | JAMB | SILL | |
| 111A | SEE ELEVATIONS | SEE ELEVATIONS | N/A | TBD | OVERHEAD SECTIONAL | N/A | N/A | TBD | TBD | TBD | |
| 111B | | | | | OVERHEAD SECTIONAL | N/A | N/A | TBD | TBD | TBD | |
| 102B | | | | | INSWING - FULL LITE | CLAD WOOD | BRONZE | SEE SHT AB.02 | SEE SHT AB.02 | FACTORY | |
| 103B | | | | | SLIDING PATIO DOOR | | | | | | |
| 103C | | | | | SLIDING PATIO DOOR | | | | | | |
| 104B | | | | | OUTSWING - FULL LITE - DOUBLE DOOR | | | | | | |

| OPENING SCHEDULE - LEVEL 3 - INTERIOR DOORS | | | | | | | | | | | |
|---|------------|-------|-------------------|----------|------------------|-------|---------|----------|----------|------|---------|
| MARKER | DIMENSION | | FIRE RATING (MIN) | HARDWARE | TYPE | FRAME | | | DETAILS | | REMARKS |
| | W | H | | | | TYPE | FINISH | HEAD | JAMB | SILL | |
| 300A | PAIR 2'-4" | 8'-0" | | TBD | PASSAGE / CLOSET | WOOD | STAINED | A3/A9.01 | A3/A9.01 | N/A | |
| 300B | 3'-0" | | | | PASSAGE | | | | | | |
| 302 | 3'-0" | | | | PASSAGE / CLOSET | | | | | | |
| 303A | PAIR 2'-4" | | | | PASSAGE / CLOSET | | | | | | |
| 304 | 3'-0" | | | | PASSAGE / CLOSET | | | | | | |
| 305A | 5'-0" | | | | BARN SLIDER | | | | | | |
| 305B | 2'-8" | | | | PRIVACY | | | | | | |
| 306 | 2'-6" | | | | PRIVACY | | | | | | |
| 307 | 3'-0" | | | | PRIVACY | | | | | | |
| 308 | 3'-0" | | | | BARN SLIDER | | | | | | |
| 309 | 3'-0" | | | | PASSAGE | | | | | | |
| 310 | 2'-6" | | | | PRIVACY | | | | | | |
| 311 | 3'-0" | | | | PASSAGE / CLOSET | | | | | | |
| 312 | 3'-0" | | | | PRIVACY | | | | | | |
| 313 | 3'-0" | | | | PRIVACY | | | | | | |
| 314 | 3'-0" | | | | BARN SLIDER | | | | | | |
| 315 | 2'-6" | | | | PRIVACY | | | | | | |

| OPENING SCHEDULE - LEVEL 2 - EXTERIOR DOORS | | | | | | | | | | | |
|---|----------------|----------------|-------------------|----------|------------------------------------|-----------|--------|---------------|---------------|---------|---------|
| MARKER | DIMENSION | | FIRE RATING (MIN) | HARDWARE | TYPE | FRAME | | | DETAILS | | REMARKS |
| | W | H | | | | TYPE | FINISH | HEAD | JAMB | SILL | |
| 200A | SEE ELEVATIONS | SEE ELEVATIONS | N/A | TBD | INSWING - FULL LITE | CLAD WOOD | BRONZE | SEE SHT AB.02 | SEE SHT AB.02 | FACTORY | |
| 202 | | | | | STACKING BIFOLD | | | | | | |
| 204A | | | | | INSWING - FULL LITE | | | | | | |
| 205 | | | | | INSWING - FULL LITE | | | | | | |
| 210A | | | | | OUTSWING - FULL LITE - DOUBLE DOOR | | | | | | |
| 210C | | | | | OUTSWING - FULL LITE - DOUBLE DOOR | | | | | | |

| OPENING SCHEDULE - LEVEL 3 - EXTERIOR DOORS | | | | | | | | | | | |
|---|----------------|----------------|-------------------|----------|------------------------------------|-----------|--------|---------------|---------------|---------|---------|
| MARKER | DIMENSION | | FIRE RATING (MIN) | HARDWARE | TYPE | FRAME | | | DETAILS | | REMARKS |
| | W | H | | | | TYPE | FINISH | HEAD | JAMB | SILL | |
| 301 | SEE ELEVATIONS | SEE ELEVATIONS | N/A | TBD | OUTSWING - FULL LITE - DOUBLE DOOR | CLAD WOOD | BRONZE | SEE SHT AB.02 | SEE SHT AB.02 | FACTORY | |
| 303B | | | | | OUTSWING - FULL LITE | | | | | | |

GENERAL FINISH NOTES

- 2012 IBC INTERIOR FINISH (CHAPTER 7, 8, 12 & 16)
- THE FACING OF ANY EXPOSED INSULATION MUST MEET A FLAME SPREAD INDEX OF 25 OR LESS IBC SECTION 719.2).
- REFER TO TABLE 721.1 FOR RATED FIRE RESISTANCE PERIODS FOR WALLS AND PARTITIONS (2012 IBC)
- THE MAXIMUM FLAME-SPREAD CLASS OF FINISH MATERIALS USED ON INTERIOR WALLS & CEILINGS SHALL NOT EXCEED THE FLAME-SPREAD LIMITATIONS OF IBC TABLE 803.9)
- INTERIOR WALL AND CEILING FINISH MATERIALS SHALL MEET WITH ASTM E84 OR UL 723
- INTERIOR FLOOR FINISHES TO COMPLY WITH 2012 IBC SECTION 804, AND NFPA 253
- INSULATION TO COMPLY WITH 2012 IBC SECTION 720
- DECORATIVE MATERIALS AND TRIMS SHALL BE RESTRICTED BY COMBUSTIBILITY AND THE FLAME PROPAGATION PERFORMANCE CRITERIA OF NFPA 701, IN ACCORDANCE WITH SECTION 806 (2012 IBC)

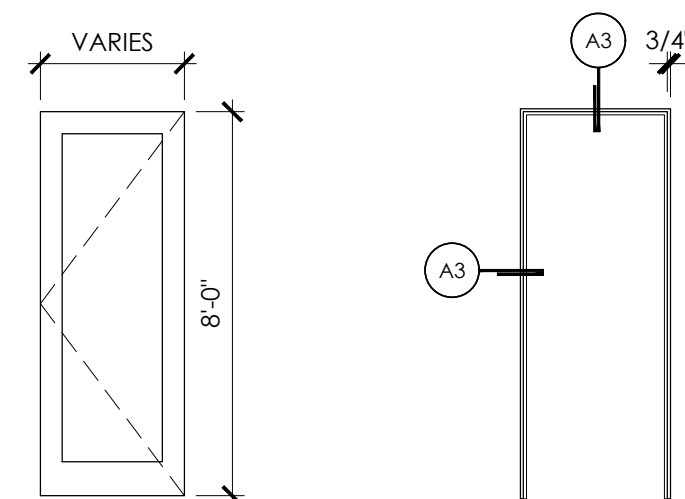

A2 INTERIOR DOOR ELEVATIONS
SCALE: 1/4" = 1'-0"

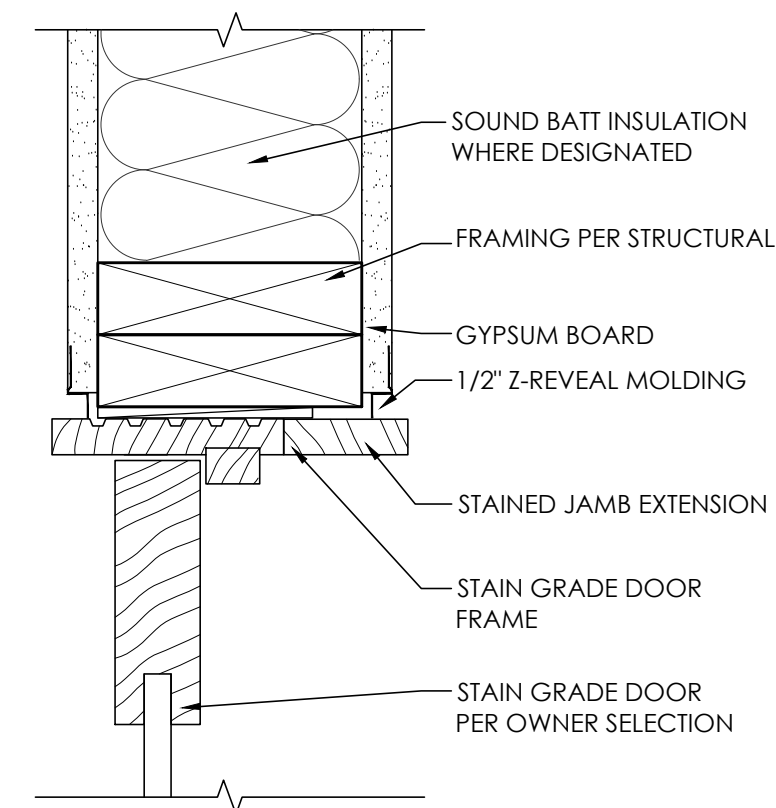

A3 INT. DOOR HEAD / JAMB DETAIL
SCALE: 1/4" = 1'-0"

GENERAL NOTES

- ALL WINDOW DIMENSIONS ARE NOMINAL. REFER TO MANUFACTURERS RECOMMENDATIONS FOR ROUGH OPENING DIMENSIONS.
- CONTRACTOR TO VERIFY ALL DIMENSIONS IN THE FIELD AND NOTIFY ARCHITECT OF ANY DISCREPANCIES PRIOR TO FABRICATION.
- ALL GLAZING IN OR WITHIN 24" OF A DOOR, OR WITHIN 18" OF FLOOR, OR WITHIN 60" OF TUB FLOOR, GLAZING ADJACENT TO STAIRS AND STAIR LANDINGS, OR ANY OTHER HAZARDOUS AREA IS TO BE TEMPERED SAFETY GLAZING. PROVIDE SAFETY GLAZING WHERE REQUIRED PER APPLICABLE CODE REQUIREMENTS.
- DOORS AND CASED OPENINGS LOCATED NEAR WALL INTERSECTIONS SHALL BE LOCATED SO THAT THE EDGE OF FINISHED OPENING IS 3" FROM FACE OF NEARBY WALL, UNLESS NOTED OTHERWISE.
- ALL WINDOWS TO BE DOUBLE GLAZED WITH A MINIMUM U-VALUE OF 0.30 OR BETTER.
- SEE SHEETS A-301 AND A-302, EXTERIOR ELEVATIONS FOR OPENING DIRECTION OF OPERABLE UNITS.
- EACH BEDROOM WINDOW MUST BE 5.7 SF MINIMUM NET CLEAR AREA (GRADE FLOOR OPENINGS CAN BE MINIMUM NET CLEAR OPEN AREA OF 5 SF), WITH 20" MINIMUM CLEAR OPEN WIDTH, 24" CLEAR OPEN HEIGHT, 44" MAXIMUM SILL HEIGHT.
- CAULK AND SEAL ALL WINDOW AND DOOR OPENINGS AND EXTERIOR PENETRATIONS.
- MINIMUM 1/2" THROW ON DEAD BOLT OR DEAD LATCH FOR DOORS.
- NOT USED
- WINDOWS WITHIN 10' OF GRADE (OR ACCESSIBLE DECK) CAPABLE OF BEING LOCKED.
- MINIMUM 1 3/8" SOLID CORE OR 20 MINUTE DOOR REQUIRED BETWEEN GARAGE AND DWELLING.

EAST MERCER RESIDENCE

4634 EAST MERCER WAY
MERCER ISLAND, WA 98040

SHEET ISSUE:

| | |
|------------|--------------------|
| 6/24/2015 | PERMIT SUBMITTAL |
| 8/29/2016 | PERMIT APPROVED |
| 6/05/2017 | REVISION TO PERMIT |
| 05/08/2018 | REVISION TO PERMIT |

MUNICIPALITY REVIEW:

PROJECT # MERCER ISLAND 15 - 015

SHEET TITLE:

WINDOW & DOOR SCHEDULES

PROJECT NO.: 20140904
DATE ISSUED: 05/08/2018

SHEET NUMBER: **A9.01**

| OPENING SCHEDULE - LEVEL 2 - EXTERIOR WINDOWS | | | | | | | | | | |
|---|----------------|----------------|----------------------------|-----------------|-----------|--------|---------------|-----------------|-----------------|---|
| MARKER | DIMENSION | | HEAD HEIGHT ABOVE SUBFLOOR | TYPE | FRAME | | DETAILS | | | REMARKS |
| | SEE ELEVATIONS | SEE ELEVATIONS | | | TYPE | FINISH | HEAD | JAMB | SILL | |
| 200 | SEE ELEVATIONS | SEE ELEVATIONS | SEE ELEVATIONS | PICTURE | CLAD WOOD | BRONZE | SEE SHT A8.02 | SEE SHEET A8.02 | SEE SHEET A8.02 | SAFETY GLASS NOTED ON ELEVATIONS - TYP. |
| 201 | | | | PICTURE | | | | | | |
| 202 | | | | PICTURE/TRANSOM | | | | | | |
| 203 | | | | PICTURE | | | | | | |
| 204 | | | | PICTURE | | | | | | |
| 205 | | | | CASEMENT | | | | | | |
| 206 | | | | PICTURE | | | | | | |
| 207 | | | | PICTURE | | | | | | |
| 208 | | | | PICTURE | | | | | | |
| 209 | | | | PICTURE | | | | | | |
| 210 | | | | CASEMENT | | | | | | |
| 211 | | | | PICTURE | | | | | | |
| 212 | | | | CASEMENT | | | | | | |
| 213 | | | | PICTURE | | | | | | |
| 214 | | | | CASEMENT | | | | | | |
| 215 | | | | PICTURE | | | | | | |
| 216 | | | | CASEMENT | | | | | | |
| 217 | | | | PICTURE | | | | | | |
| 218 | | | | PICTURE | | | | | | |
| 219 | | | | PICTURE | | | | | | |
| 220 | | | | PICTURE | | | | | | |
| 221 | | | | PICTURE | | | | | | |
| 222 | | | | PICTURE | | | | | | |
| 223 | | | | PICTURE | | | | | | |
| 224 | | | | PICTURE | | | | | | |
| 225 | | | | PICTURE | | | | | | |
| 226 | | | | CASEMENT | | | | | | |
| 227 | | | | PICTURE | | | | | | |
| 228 | | | | PICTURE | | | | | | |
| 229 | | | | PICTURE | | | | | | |
| 230 | ✓ | ✓ | ✓ | PICTURE | ✓ | ✓ | ✓ | ✓ | ✓ | |

| OPENING SCHEDULE - LEVEL 2 - EXTERIOR WINDOWS | | | | | | | | | | |
|---|----------------|----------------|----------------------------|----------|-----------|--------|---------------|---------------|---------------|---|
| MARKER | DIMENSION | | HEAD HEIGHT ABOVE SUBFLOOR | TYPE | FRAME | | DETAILS | | | REMARKS |
| | SEE ELEVATIONS | SEE ELEVATIONS | | | TYPE | FINISH | HEAD | JAMB | SILL | |
| 231 | SEE ELEVATIONS | SEE ELEVATIONS | SEE ELEVATIONS | PICTURE | CLAD WOOD | BRONZE | SEE SHT A8.02 | SEE SHT A8.02 | SEE SHT A8.02 | SAFETY GLAZING NOTED ON ELEVATIONS - TYP. |
| 232 | | | | PICTURE | | | | | | |
| 233 | | | | PICTURE | | | | | | |
| 234 | | | | PICTURE | | | | | | |
| 235 | | | | PICTURE | | | | | | |
| 236 | | | | PICTURE | | | | | | |
| 237 | | | | PICTURE | | | | | | |
| 238 | | | | CASEMENT | | | | | | |
| 239 | | | | CASEMENT | | | | | | |
| 240 | | | | CASEMENT | | | | | | |
| 241 | | | | CASEMENT | | | | | | |
| 242 | | | | CASEMENT | | | | | | |
| 243 | | | | PICTURE | | | | | | |
| 244 | | | | PICTURE | | | | | | |
| 245 | | | | CASEMENT | | | | | | |
| 246 | | | | CASEMENT | | | | | | |
| 247 | | | | PICTURE | | | | | | |
| 248 | | | | PICTURE | | | | | | |
| 249 | | | | TRANSOM | | | | | | |
| 250 | | | | PICTURE | | | | | | |
| 251 | | | | PICTURE | | | | | | |
| 252 | | | | PICTURE | | | | | | |
| 253 | | | | PICTURE | | | | | | |
| 254 | | | | PICTURE | | | | | | |
| 255 | | | | PICTURE | | | | | | |
| 256 | | | | PICTURE | | | | | | |
| 257 | | | | PICTURE | | | | | | |
| . | ✓ | ✓ | ✓ | | ✓ | ✓ | ✓ | ✓ | ✓ | |

CONSULTANT: _____

PROFESSIONAL SEAL: _____



PROJECT: _____

a project for:

PO BOX 1733 AUBURN, WA 98071
 Phone: (206) 724-1072

EAST MERCER RESIDENCE

4634 EAST MERCER WAY
 MERCER ISLAND, WA 98040

SHEET ISSUE: _____

| | |
|--------------|--------------------|
| 6/24/2015 | PERMIT SUBMITTAL |
| 8/29/2016 | PERMIT APPROVED |
| 1 6/05/2017 | REVISION TO PERMIT |
| 2 05/08/2018 | REVISION TO PERMIT |

MARK DATE DESCRIPTION

MUNICIPALITY REVIEW: _____

PROJECT # MERCER ISLAND 15 - 015

SHEET TITLE: _____

WINDOW SCHEDULE

PROJECT NO.: 20140904

DATE ISSUED: 05/08/2018

SHEET NUMBER: _____

A9.02
 Exhibit 5

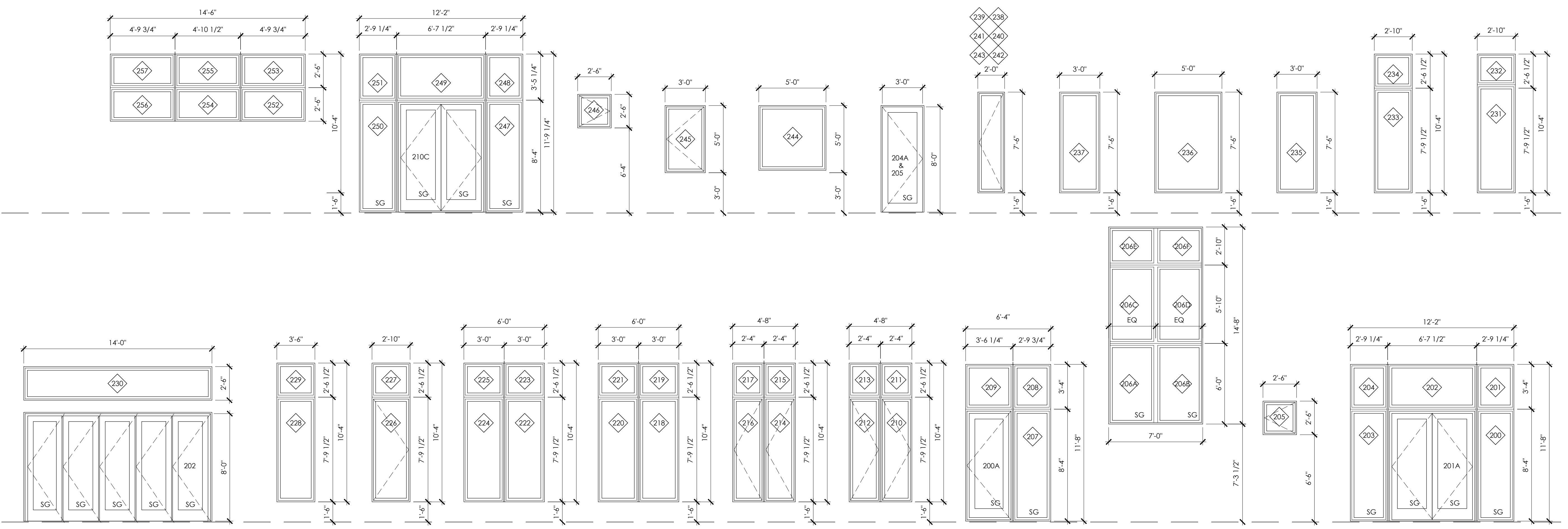

A1 EXTERIOR DOOR AND WINDOW ELEVATIONS - LEVEL 2
 SCALE: 1/4" = 1'-0"

GENERAL STRUCTURAL NOTES

1. ALL MATERIALS, WORKMANSHIP, DESIGN, AND CONSTRUCTION SHALL CONFORM TO THE DRAWINGS, SPECIFICATIONS, THE INTERNATIONAL BUILDING CODE (2012 EDITION) AND MODIFICATIONS TO THE INTERNATIONAL BUILDING CODE, BY THE LOCAL JURISDICTION.

2. DESIGN LOAD CRITERIA

DEAD LOADS

| | |
|----------------|--------|
| ROOF | 25 PSF |
| FLOORS | N/A |
| DECKS | N/A |
| EXTERIOR WALLS | 10 PSF |
| INTERIOR WALLS | 8 PSF |

LIVE LOADS

| | |
|----------------------|--------|
| ROOF | 20 PSF |
| FLOOR / LIVING SPACE | N/A |
| DECKS / BALCONIES | N/A |

SNOWLOADS

| | |
|-------------------|----------------------|
| GROUND LOAD | 25 PSF |
| ROOF SNOW LOAD | 25 PSF |
| EXPOSURE FACTOR | C _e = 0.9 |
| IMPORTANCE FACTOR | I _s = 1.0 |
| THERMAL FACTOR | C _t = 1.0 |

WIND

| | |
|---|---------|
| ULTIMATE DEIGN WIND SPEED (V _{ult}) | 110 MPH |
| ASD WIND SPEED (V _{asd}) | 85 MPH |
| WIND EXPOSURE | C |
| IMPORTANCE FACTOR I _w | 1.0 |
| ADJUSTMENT FACTOR λ | 1.0 |
| WIND SPEED UP FACTOR | 1.0 |
| ROOF SLOPE | flat |

SEISMIC

| | |
|---|------------------------|
| SEISMIC USE GROUP | I |
| IMPORTANCE FACTOR I _e | 1.0 |
| SITE CLASS | D |
| SEISMIC DESIGN CATEGORY | D |
| RESPONSE FACTOR FOR LIGHT FRAME CONSTRUCTION | R = 6.5 |
| RESPONSE FACTOR FOR ORDINARY STEEL MOMENT FRAME | R = 3.5 |
| MAPPED ACCELERATION (PER USGS) | S _s = 1.276 |
| BASE SHEAR | V = 29,350 |
| SEISMIC RESPONSE COEFFICIENT | C _s = 0.131 |

PER GEOTECHNICAL REPORT FILE NO. 14-128, 02/02/2015, PanGEO

| | |
|---|-----------|
| ALL SOIL PRESURE | 2,500 PSF |
| FRICTION COEFFICIENT | 0.4 |
| EQUIVALENT FLUID PRESSURE AT REST | 35 PSF |
| AT REST WITH BACKSLOPE | 45 PSF |
| PASSIVE SEISMIC HORIZONTAL PRESSURE (PASSIVE) | 55 PSF |
| | 300 PSF |
| | 8H |
| | 375 pcf |

- STRUCTURAL DRAWINGS SHALL BE USED IN CONJUNCTION WITH ARCHITECTURAL DRAWINGS FOR BIDDING AND CONSTRUCTION. CONTRACTOR SHALL VERIFY DIMENSIONS AND CONDITIONS FOR COMPATIBILITY AND SHALL NOTIFY ARCHITECT AND STRUCTURAL ENGINEER OF ANY DISCREPANCIES PRIOR TO CONSTRUCTION.
- CONTRACTOR SHALL VERIFY ALL EXISTING DIMENSIONS, MEMBER SIZES, AND CONDITIONS PRIOR TO COMMENCING WORK. ALL DIMENSIONS OF EXISTING CONSTRUCTION SHOWN ON THE DRAWINGS ARE INTENDED AS GUIDELINES ONLY AND MUST BE VERIFIED.
- CONTRACTOR SHALL PROVIDE TEMPORARY BRACING FOR THE STRUCTURE AND STRUCTURAL COMPONENTS UNTIL ALL FINAL CONNECTIONS HAVE BEEN COMPLETED IN ACCORDANCE WITH THE PLANS.
- CONTRACTOR SHALL BE RESPONSIBLE FOR ALL SAFETY PRECAUTIONS AND THE METHODS, TECHNIQUES, SEQUENCES OR PROCEDURES REQUIRED TO PERFORM THE CONTRACTORS WORK. THE STRUCTURAL ENGINEER HAS NO OVERALL SUPERVISORY AUTHORITY OR ACTUAL AND/OR DIRECT RESPONSIBILITY FOR THE SPECIFIC WORKING CONDITIONS AT THE SITE AND/OR FOR ANY HAZARDS RESULTING FROM THE ACTIONS OF ANY TRADE CONTRACTOR. THE STRUCTURAL ENGINEER HAS NO DUTY TO INSPECT, SUPERVISE, NOTE, CORRECT, OR REPORT ANY HEALTH OR SAFETY DEFICIENCIES OF THE OWNER, CONTRACTORS, OR OTHER SITE ENTITIES OR PERSONS AT THE PROJECT SITE.
- CONTRACTOR-INITIATED CHANGES SHALL BE SUBMITTED IN WRITING TO THE ARCHITECT AND STRUCTURAL ENGINEER FOR APPROVAL PRIOR TO FABRICATION OR CONSTRUCTION. CHANGES SHOWN ON SHOP DRAWINGS ONLY WILL NOT SATISFY THIS REQUIREMENT.
- DRAWINGS INDICATE GENERAL AND TYPICAL DETAILS OF CONSTRUCTION. WHERE CONDITIONS ARE NOT SPECIFICALLY INDICATED BUT ARE OF SIMILAR CHARACTER TO DETAILS SHOWN, SIMILAR DETAILS OF CONSTRUCTION SHALL BE USED, SUBJECT TO REVIEW AND APPROVAL BY THE ARCHITECT AND THE STRUCTURAL ENGINEER.
- ALL STRUCTURAL SYSTEMS WHICH ARE TO BE COMPOSED OF COMPONENTS TO BE FIELD ERECTED SHALL BE SUPERVISED BY THE SUPPLIER DURING MANUFACTURING, DELIVERY, HANDLING, STORAGE AND ERECTION IN ACCORDANCE WITH INSTRUCTIONS PREPARED BY THE SUPPLIER.

FOUNDATIONS

- ALL FOOTINGS AND FOUNDATIONS SHALL BE SUPPORTED BY COMPETENT NATIVE SOIL 18" BELOW FINISHED GRADE FOR EXTERIOR SIDE AND 12" FOR INTERIOR FOOTINGS, FREE OF ORGANIC MATERIALS. OVEREXCAVATION MIGHT BE NEEDED TO REACH THE COMPETENT SOIL.
- FOOTINGS AND FOUNDATION EXCAVATION SHALL BE FREE OF LOOSE SOILS, SLOUGHS, DEBRIS, AND FREE OF WATER AT ALL TIMES.
- FOUNDATION WALL BACKFILL SHALL BE PLACED SIMULTANEOUSLY ON BOTH SIDES OF WALL PROVIDING 4" PERFORATED PIPE (AS REQUIRED) FOR SUBSURFACE DRAINAGE.
- U.N.O. IN AN APPROVED GEOTECHNICAL REPORT, THE FOLLOWING METHOD FOR BACKFILL PLACEMENT AND COMPACTION IS TO BE USED:

EXCEPT FOR BACKFILL AGAINST BELOW-GRADE WALLS OR RETAINING WALLS, ALL OTHER STRUCTURAL FILL AND STRUCTURAL BACKFILL MATERIALS SHALL BE PLACED IN RELATIVELY HORIZONTAL LOOSE LIFTS NOT EXCEEDING 10 INCHES IN THICKNESS AND COMPACTED TO AT LEAST 95 PERCENT OF THE MODIFIED PROCTOR (ASTM D1557) MAXIMUM DENSITY AT MOISTURE CONTENTS WITHIN TWO (2) PERCENT OF OPTIMUM. THE SPECIFIED COMPACTION DENSITY AND MOISTURE CONTENT OF EACH LIFT MUST BE VERIFIED BY INSPECTION, PRIOR TO PLACEMENT OF SUBSEQUENT LIFTS. BACKFILL AGAINST BELOW-GRADE WALLS AND RETAINING WALLS SHOULD BE COMPACTED AS DESCRIBED ABOVE TO ONLY 90 PERCENT OF THE MAXIMUM DRY DENSITY AS DETERMINED BY ASTM D1557.
- FOOTING SIZE SHALL BE AS INDICATED ON DRAWINGS OR MIN. AS PER IBC SECTION 1806.
- WHERE THE SURFACE IS SLOPED MORE THAN ONE (1) FOOT IN TEN (10) FEET THE FOUNDATION SHALL BE LEVEL OR STEPPED SO THAT BOTH, TOP AND BOTTOM, OF SUCH FOUNDATION ARE LEVEL PER IBC.
- WHERE STRUCTURAL COLUMNS AND POSTS ARE EXPOSED TO WATER SPLASH ABOVE, A CONCRETE SURFACE OR TO THE WEATHER, PROVIDE A MIN. OF 1" ABOVE CONCRETE SURFACE, OR 8" ABOVE THE EXPOSED EARTH PER IBC.

CONCRETE

- CONCRETE SHALL BE MIXED, PROPORTIONED, CONVEYED AND PLACED IN ACCORDANCE WITH IBC SECTION 1905, 1906, AND ACI 301. STRENGTH AT AGE 28 DAYS AND MIX CRITERIA SHALL BE AS FOLLOWS, U.N.O.:

MEMBER TYPE (IN) PSI MAX AGGR. MAX W/C RATIO
- CONCRETE MIX FOR FOUNDATION AND SLAB:
CEMENT: 5.5 SACK TYPE I NORMAL PORTLAND CEMENT
1,210 LBS OF WET SAND
1,925 LBS GRAVEL
- REINFORCING STEEL SHALL CONFORM TO ASTM A615, GRADE 60, F_y = 60,000 PSI, UNLESS NOTED OTHERWISE. WELDED WIRE FABRIC SHALL CONFORM TO ASTM-185.
- DETAILING OF REINFORCING STEEL (INCLUDING HOOKS AND BENDS) SHALL BE IN ACCORDANCE WITH ACI 315-92 AND ACI 318-08. LAP ALL REINFORCEMENTS IN ACCORDANCE WITH "THE REINFORCING SPLICE AND DEVELOPMENT LENGTH SCHEDULE". PROVIDE CORNER BARS AT ALL WALL AND FOOTING INTERSECTIONS. LAP ADJACENT MATS OF WELDED WIRE FABRIC A MINIMUM OF 8" AT SIDES AND ENDS.
- NO BARS PARTIALLY EMBEDDED IN HARDENED CONCRETE SHALL BE FIELD BENT UNLESS SPECIFICALLY SO DETAILED AND APPROVED BY THE STRUCTURAL ENGINEER.
- CONCRETE PROTECTION (COVER) FOR REINFORCING STEEL SHALL BE AS FOLLOWS:
FOOTINGS AND OTHER UNFORMED SURFACES CAST AGAINST AND PERMANENTLY EXPOSED TO EARTH 3"
FORMED SURFACES EXPOSED TO EARTH OR WEATHER (NO. 6 BARS OR LARGER) 2"
(NO 5 BARS OR SMALLER) 1-1/2"
COLUMN TIES OR SPIRALS AND BEAM STIRRUPS 1-1/2"
SLABS AND WALLS: GREATER OF BAR DIAMETER + 1/8 OR 3/4"

- CAST-IN-PLACE CONCRETE: SEE ARCHITECTURAL DRAWINGS FOR EXACT LOCATIONS AND DIMENSIONS OF DOOR AND WINDOW OPENINGS IN ALL CONCRETE WALLS. SEE MECHANICAL DRAWINGS FOR SIZE AND LOCATION OF MISCELLANEOUS MECHANICAL OPENINGS THROUGH CONCRETE WALLS.
- NON-SHRINK GROUT SHALL BE FURNISHED BY AN APPROVED MANUFACTURER AND SHALL BE MIXED AND PLACED IN STRICT ACCORDANCE WITH THE MANUFACTURER'S PUBLISHED RECOMMENDATIONS. GROUT STRENGTH SHALL BE AT LEAST EQUAL TO THE MATERIAL ON WHICH IT IS PLACED (2,500 PSI MIN).

ANCHORAGE

- POXY-GROUTED ITEMS (THREADED RODS OR REINFORCING BARS) SPECIFIED ON THE DRAWINGS SHALL BE INSTALLED WITH SIMPSON EPOXY "SET-XP" OR EQUAL. SPECIAL INSPECTION IS REQUIRED. RODS SHALL BE ASTM A-36 UNLESS NOTED OTHERWISE.
- DRIVEN PINS AND OTHER POWDER ACTUATED FASTENERS SHALL BE LOW VELOCITY TYPE. INSTALL IN STRICT ACCORDANCE WITH THE MANUFACTURER'S RECOMMENDATIONS. MINIMUM EMBEDMENT IN CONCRETE SHALL BE 1" UNLESS OTHERWISE NOTED. MAINTAIN AT LEAST 3" TO NEAREST CONCRETE

STEEL

- STRUCTURAL STEEL FABRICATION, ERECTION AND WELDING INSPECTION SHALL COMPLY WITH THE SPECIAL INSPECTION SCHEDULE.
STRUCTURAL STEEL SHALL BE GRADE A-36 UNLESS NOTED OTHERWISE.
ARCHITECTURALLY EXPOSED STEEL SHALL CONFORM TO SECTION 10 OF THE AISC CODE OF STANDARD PRACTICE FOR STEEL BUILDINGS AND BRIDGES.
- ALL ANCHORS EMBEDDED IN MASONRY OF CONCRETE SHALL BE A307 HEADED BOLTS OR A36 THREADED ROD.
- ALL WELDING SHALL BE IN CONFORMANCE WITH AISC AND A.W.S STANDARDS AND SHALL BE PERFORMED BY W.A.B.O. CERTIFIED WELDERS USING E70 XX ELECTRODES. ONLY PREQUALIFIED WELDS (AS DEFINED BY A.W.S.) SHALL BE USED ALL COMPLETE JOINT PENETRATION GROOVE WELDS SHALL BE MADE WITH A FILLER MATERIAL THAT HAS A MINIMUM CVN TOUGHNESS OF 20 FT LBS AT -20 DEGREES F, AS DETERMINED BY AWS CLASSIFICATION OR MANUFACTURER CERTIFICATION
- WELDING INSPECTION SHALL BE IN COMPLIANCE WITH AWS D1.1.

WOOD

- ALL SOLID LUMBER TO BE GRADED BY WCLIB OR WWSA. ALL LUMBER SHALL BE HEM-FIR #2 (HF #2) OR BETTER. ALL SOLID LUMBER 5" X 4" OR LARGER SHALL BE DOUGLAS FIR #2 (DF #2) U.N.O. ALL GLUE-LAMINATED LUMBER SHALL BE GLULAM 24F-1.8E WS.
DESIGN VALUES FOR GLULAM BEAMS
FLEXURAL STRESS TENSION ZONE 2,400 PSI
FLEXURAL STRESS COMPRESSION ZONE 1,850 PSI
COMPRESSION PERPENDICULAR TO GRAIN 650 PSI
SHEAR 266 PSI
APPARENT E 1.8x16 lb-in²
TRUE E 1.9x10 lb-in²
- LUMBER IN CONTACT WITH CONCRETE AND ALL EXTERIOR WOOD SHALL BE PRESSURE TREATED, ALL CONNECTORS GALVANIZED.
- INSTALL SOLID BLOCKING BTWN JOISTS AT ALL BEARING POINTS.
- THROUGH BOLTS AND LAG BOLTS SHALL BE ASTM A307. PROVIDE MALLEABLE IRON WASHER AT ALL BOLT AND LAG BOLT LOATIONS. PROVIDE CUT WASHER FOR ALL BOLTS PROTRUDING BEARING WOOD.
- ALL METAL (CONNECTORS, NAILS, BOLTS, ETC.) IN CONTACT WITH P.T. WOOD SHALL BE HOT DIPPED GALVANIZED.
- U.N.O. CONNECTORS AND FASTENERS SHALL COMPLY WITH IBC TABLE 2304.9.1

OPEN WEB TRUSSES

- PER IBC 2012 1704.2.2, PREFABRICATED OPEN-WEB JOISTS SHALL BE FABRICATED BY A REGISTERED AND APPROVED FABRICATOR. AT COMPLETION OF FABRICATION, THE APPROVED FABRICATOR SHALL SUBMIT A CERTIFICATE OF COMPLIANCE TO THE BUILDING OFFICIAL STATING THAT THE WORK WAS PERFORMED IN ACCORDANCE WITH THE APPROVED CONSTRUCTION DOCUMENTS.

NOTE:

NO STRUCTURAL CHANGES FROM THE APPROVED PLANS SHALL BE MADE IN THE FIELD UNLESS PRIOR TO MAKING CHANGES, WRITTEN APPROVAL IS OBTAINED FROM THE ENGINEER OF RECORD. IF CHANGES ARE MADE WITHOUT WRITTEN APPROVAL, SUCH CHANGES SHALL BE THE LEGAL AND FINANCIAL RESPONSIBILITY OF THE CONTRACTOR OR SUB-CONTRACTORS INVOLVED AND SHALL BE THEIR RESPONSIBILITY TO REPLACE OR REPAIR THE CONDITION AS DIRECTED BY THE ENGINEER.

| COMPARISON OF COMMON, BOX AND SINKER NAIL DIMENSIONS (inches) OF THE SAME PENNYWEIGHT. | | | | | | |
|--|----------|-------------|-------|-------|-------|-------|
| TYPE | FEATURE | PENNYWEIGHT | | | | |
| | | 6d | 8d | 10d | 12d | 16d |
| COMMON | Length | 2 | 2-1/2 | 3 | 3-1/4 | 3-1/2 |
| | Diameter | 0.113 | 0.131 | 0.148 | 0.148 | 0.162 |
| | Head | 0.226 | 0.281 | 0.312 | 0.312 | 0.344 |
| BOX | Length | 2 | 2-1/2 | 3 | 3-1/4 | 3-1/2 |
| | Diameter | 0.099 | 0.113 | 0.128 | 0.128 | 0.135 |
| | Head | 0.266 | 0.297 | 0.312 | 0.312 | 0.344 |
| SINKER | Length | 1-7/8 | 2-3/8 | 2-7/8 | 3-1/8 | 3-1/4 |
| | Diameter | 0.092 | 0.113 | 0.120 | 0.135 | 0.148 |
| | Head | 0.231 | 0.266 | 0.281 | 0.312 | 0.344 |

| PROTECTION FOR REINFORCEMENT OF CAST IN-PLACE CONCRETE | MIN. COVER |
|--|----------------|
| Concrete cast against and permanently exposed to earth | 3" |
| Concrete exposed to earth or weather | |
| Wall panels: No. 6 through No. 18 bars No. 5 bars, W31 or D31 wire, and smaller | 2" 1 1/2" |
| Concrete exposed to neither earth or weather Slabs, walls, and joists: No. 14 and no. 18 bars No. 11 and smaller bars | 1 1/2" 3/4" |
| Beams and Columns: Primary reinforcement, ties, stirrups, and spirals | 1 1/2" |
| Shells and folded-plate members: No. 6 bars and larger | 3/4" |
| No. 5 bars, W31 or D31 or smaller | 3/4" |



REVISION 07/13/16

| | | |
|---|----------------------------------|--------------------|
| <p>tec instruct LLC 6830 NE Bothell Way - Suite C, PMB 181, Kenmore, WA 98028 Telephone (206) 553 9076 - Fax (206) 529 4408</p> | | |
| BUILDER: | Barcelo Homes | SHEET S1 |
| JOB SITE: | 4634 E Mercer Way, Mercer Island | |
| PARCEL NO.: | WA 98040 | |
| DESCRIPTION: | new SFR | |
| DATE: | 03/11/15 SCALE: as noted | |
| ENGINEER: | Roland Heimisch, P. E. | |

Statement of special inspections

General

The owner shall comply an approved agency for the special inspections for the construction of this project

A quality assurance and inspection plan from an AISC approved fabricator is required to satisfy the inspection requirements.

The following systems and components shall be inspected

| Type | Standard |
|------|----------|
|------|----------|

At completion of fabrication, the approved fabricator shall submit a certificate of compliance to the building official stating that the work was performed in accordance with the approved construction documents

Special inspections for structural steel

| | | |
|---|--------------|----------|
| Steel sections, steel grade, location of installation | all elements | AISC 360 |
|---|--------------|----------|

Special inspections for steel construction other than structural steel

| | | |
|-----------------------|----------|----------|
| Inspection of welding | periodic | AWS D1.3 |
|-----------------------|----------|----------|

Special inspections for concrete construction

| | | |
|---|----------|-----------------------------|
| Inspection of reinforcing steel | periodic | ACI 318 3.5, 7.1-7.7 |
| Inspection of anchors post-installed in hardened concrete members | periodic | ACI 318 3.8.6, 8.13, 21.2.8 |
| Verifying use of required design mix | periodic | ACI 318 Ch 4,5.2-5.4 |
| Inspect formwork for shape, locations, and dimensions | periodic | ACI 318 6.1.1 |



REVISION 05/29/16

tec instruct LLC

6830 NE Bothell Way - Suite C, PMB 181, Kenmore, WA 98028
Telephone (206) 553 9076 - Fax (206) 529 4408

ENGINEERING

| | | | |
|--------------|----------------------------------|-------|-----------------|
| BUILDER: | Barcelo Homes | SHEET | |
| JOB SITE: | 4634 E Mercer Way, Mercer Island | S1.1 | |
| PARCEL NO.: | WA 98040 | | |
| DESCRIPTION: | new SFR | | |
| DATE: | 03/11/15 | | SCALE: as noted |
| ENGINEER: | Roland Heimisch, P. E. | | |

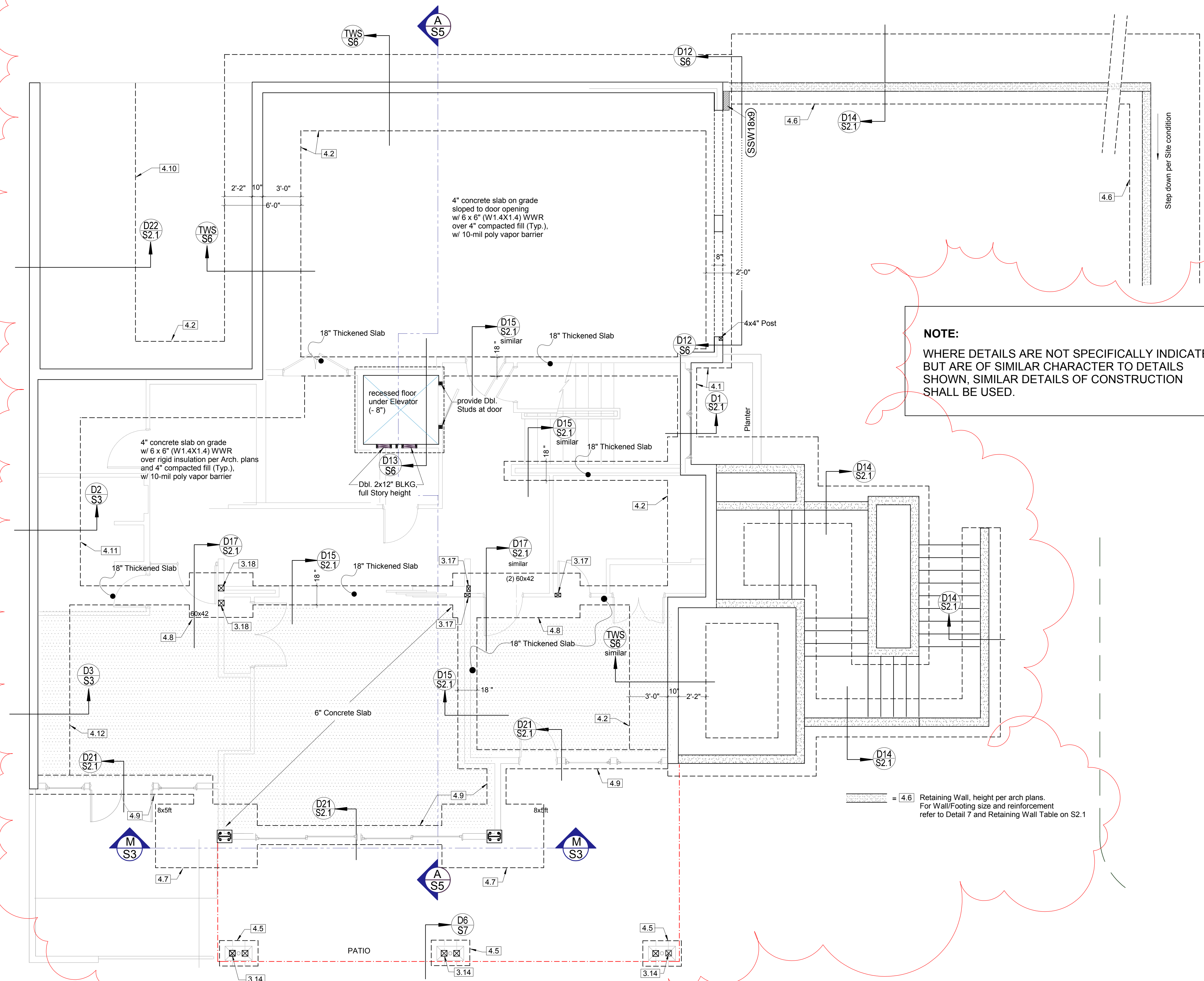

NOTE:
 WHERE DETAILS ARE NOT SPECIFICALLY INDICATED
 BUT ARE OF SIMILAR CHARACTER TO DETAILS
 SHOWN, SIMILAR DETAILS OF CONSTRUCTION
 SHALL BE USED.

| KEY NO. | STRUCTURAL MEMBERS |
|-------------------|--|
| FOUNDATION | |
| 4.1 | Cont. Footing, fc = 2,500 psi, 18x12" |
| 4.2 | Basement Wall 10" w/ Cont. Footing fc = 2,500 psi, 72x16" |
| 4.3 | Basement Wall 8" w/ Cont. Footing fc = 2,500 psi, 48x12" |
| 4.4 | Basement Wall 8" w/ Cont. Footing fc = 2,500 psi, 36x12" |
| 4.5 | Spread Footing, fc = 2,500 psi, 24x24x10" |
| 4.6 | Retaining Wall, fc = 2,500 psi, 8" wall thickness, Ftg size and reinforcement per Detail 14/Table S2.1 |
| 4.7 | Spread Footing under Moment Frame fc = 2,500 psi, 8ftx5ftx2ft |
| 4.8 | Spread Footing, fc = 2,500 psi, 60x48x10" |
| 4.9 | Cont. Footing, fc = 2,500 psi, 18x18" |
| 4.10 | Retaining Wall, fc = 2,500 psi, 8" wall w/ Ftg 8'-4"x1'-4" |
| 4.11 | Retaining Wall, fc = 2,500 psi, 8" wall w/ Ftg 48x10" |
| 4.12 | Retaining Wall, fc = 2,500 psi, 8" wall w/ Ftg 38x12" |

4.6 Retaining Wall, height per arch plans.
 For Wall/Footing size and reinforcement
 refer to Detail 7 and Retaining Wall Table on S2.1



REVISION 06/18/17

| | | |
|--|----------------------------------|-----------------|
| tec instruct LLC 6830 NE Bothell Way - Suite C, PMB 181, Kenmore, WA 98028 Telephone (206) 553 9076 - Fax (206) 529 4408 ENGINEERING | | |
| BUILDER: | Barcelo Homes | SHEET |
| JOB SITE: | 4634 E Mercer Way, Mercer Island | S2 |
| PARCEL NO.: | WA 98040 | |
| DESCRIPTION: | new SFR | |
| DATE: | 03/11/15 | SCALE: as noted |
| ENGINEER: | Roland Heimisch, P. E. | |

RETAINING WALL SCHEDULE

| H (ft.) | B1 | ts | B2 | tf | Stem Reinforcing | | | Footing Reinforcing | | | |
|---------|--------|-----|--------|-----|------------------|---------------|--------|---------------------|--------------|--------------|---------------|
| | | | | | horiz. | vert. | splice | Top Layer | | Bottom Layer | |
| | | | | | | | | cont. | perp. | cont. | perp. |
| 3'-0" | 1'-0" | 8" | 1'-0" | 12" | #4 @ 12" o.c. | #4 @ 12" o.c. | 2ft | - | - | (2) #4 | #4 @ 12" o.c. |
| 4'-0" | 1'-0" | 8" | 1'-4" | 12" | #4 @ 12" o.c. | #4 @ 12" o.c. | 2ft | - | - | (3) #4 | #4 @ 12" o.c. |
| 5'-0" | 1'-4" | 8" | 1'-6" | 10" | #4 @ 12" o.c. | #4 @ 16" o.c. | 3ft | - | - | (3) #4 | #4 @ 16" o.c. |
| 6'-0" | 1'-4" | 8" | 2'-0" | 10" | #4 @ 12" o.c. | #4 @ 12" o.c. | 3ft | - | - | (4) #4 | #4 @ 12" o.c. |
| 8'-0" | 1'-10" | 8" | 2'-9" | 12" | #4 @ 12" o.c. | #5 @ 9" o.c. | 3ft | (6) #4 | #4 @ 9" o.c. | (6) #4 | #4 @ 9" o.c. |
| 10'-0" | 2'-0" | 10" | 3'-10" | 14" | #5 @ 12" o.c. | #5 @ 8" o.c. | 4ft | (8) #4 | #5 @ 8" o.c. | (8) #4 | #4 @ 8" o.c. |
| 12'-0" | 2'-6" | 10" | 4'-2" | 10" | #5 @ 12" o.c. | #6 @ 6" o.c. | 4ft | (8) #4 | #5 @ 6" o.c. | (8) #4 | #4 @ 6" o.c. |

RETAINING WALL WITH SLOPED BACKFILL

| | | | | | | | | | | | |
|--------|-------|-----|-------|-----|---------------|--------------|-----|--------|--------------|--------|--------------|
| 12'-0" | 3'-0" | 12" | 5'-0" | 16" | #5 @ 12" o.c. | #6 @ 6" o.c. | 4ft | (8) #4 | #5 @ 6" o.c. | (8) #4 | #4 @ 6" o.c. |
|--------|-------|-----|-------|-----|---------------|--------------|-----|--------|--------------|--------|--------------|

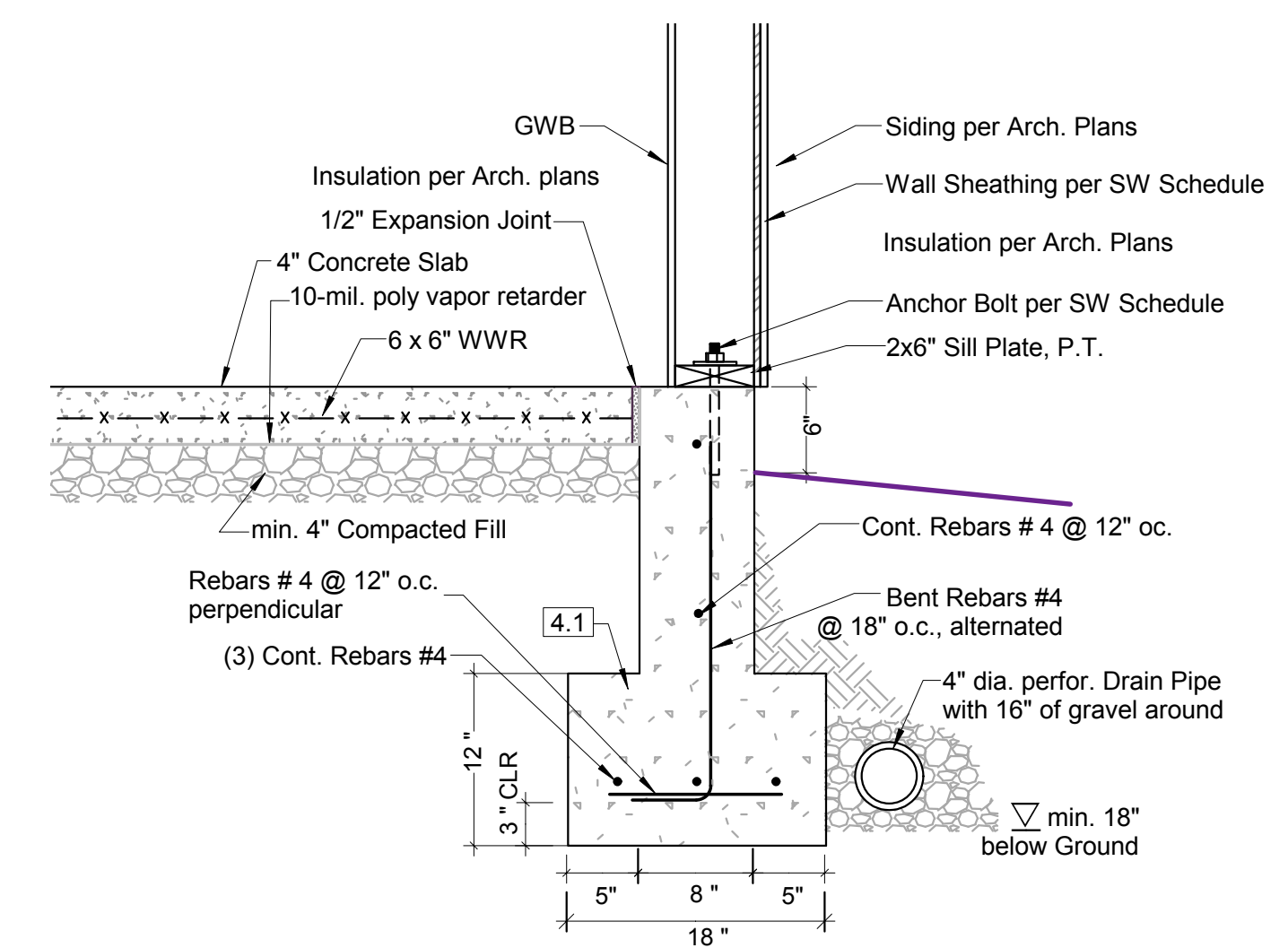

DETAIL 1 SCALE: 1" = 1'-0" (1:12)

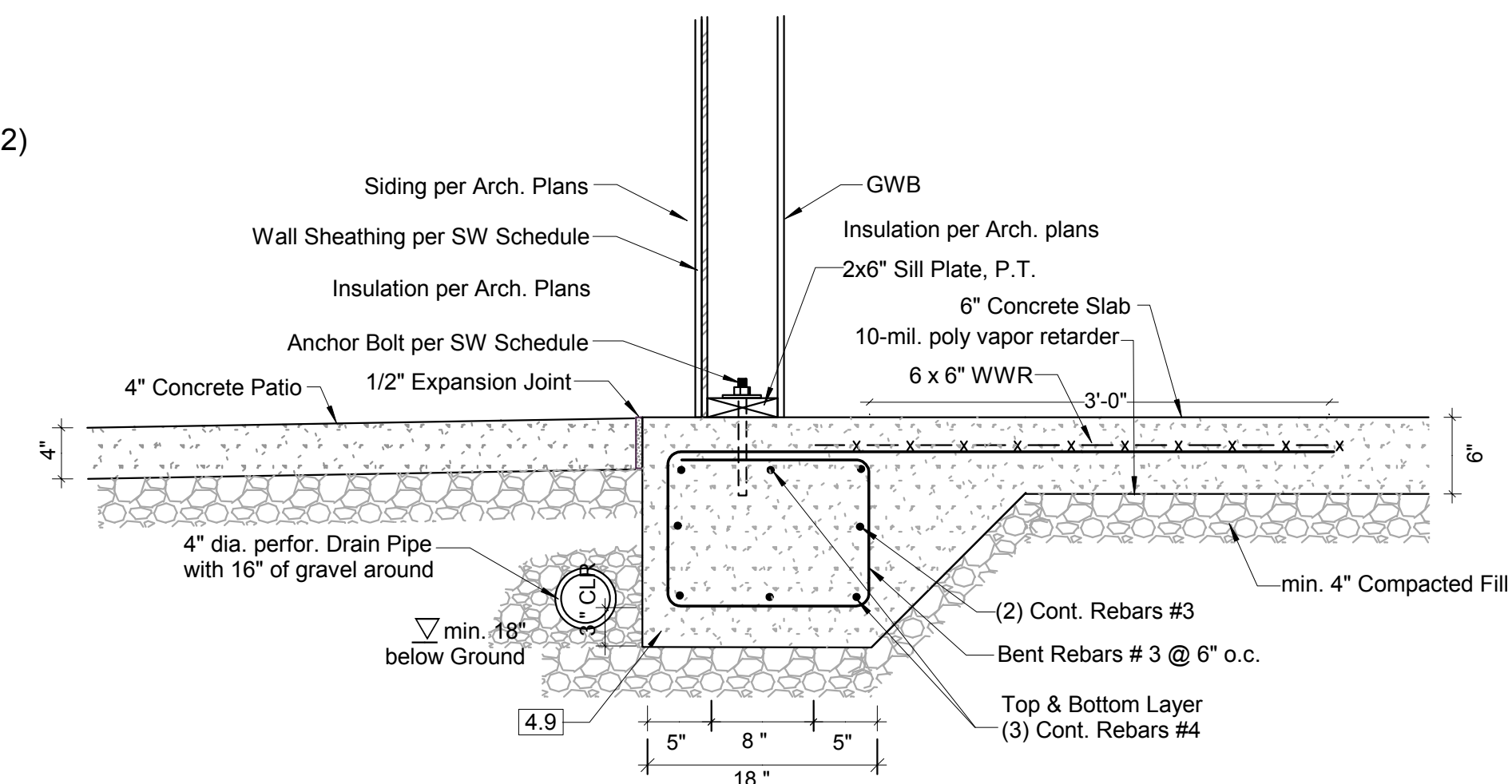

DETAIL 21 SCALE: 1" = 1'-0" (1:12)

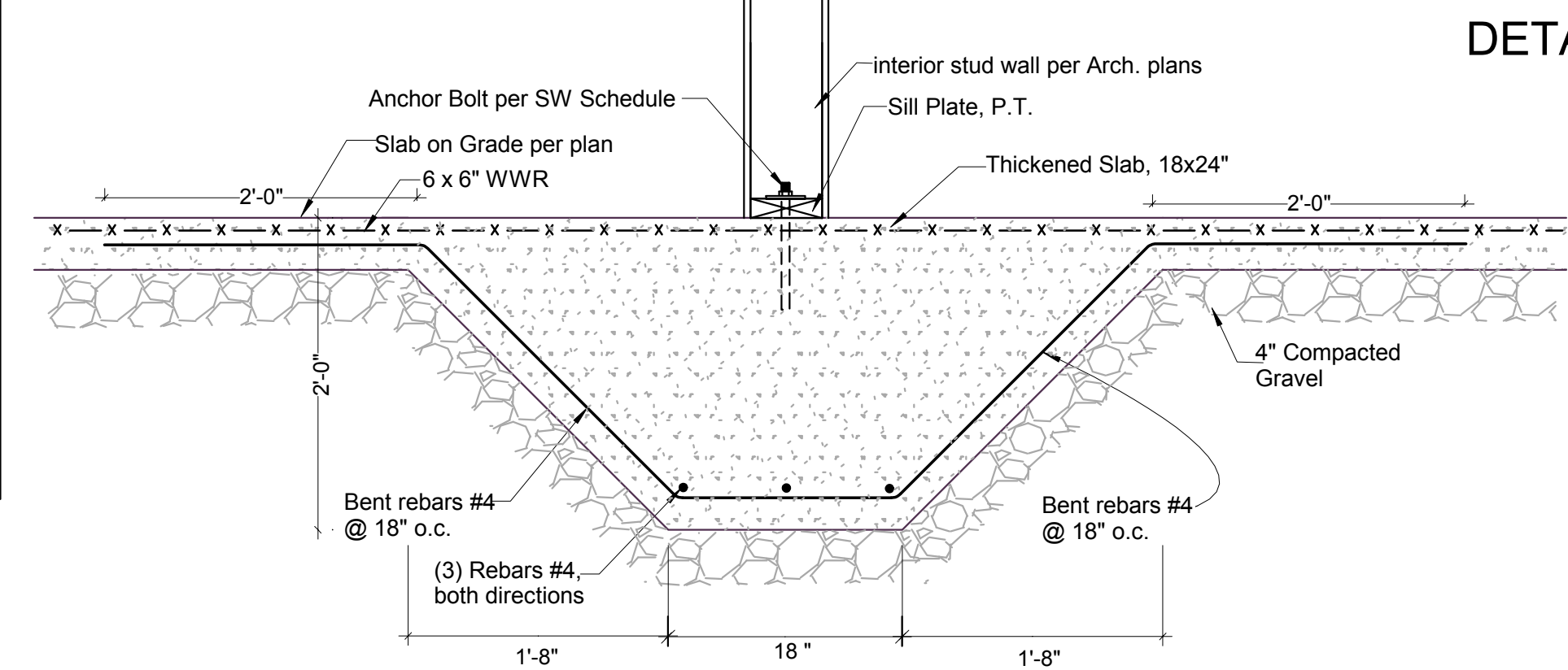

DETAIL 15 SCALE: 1" = 1'-0" (1:12)

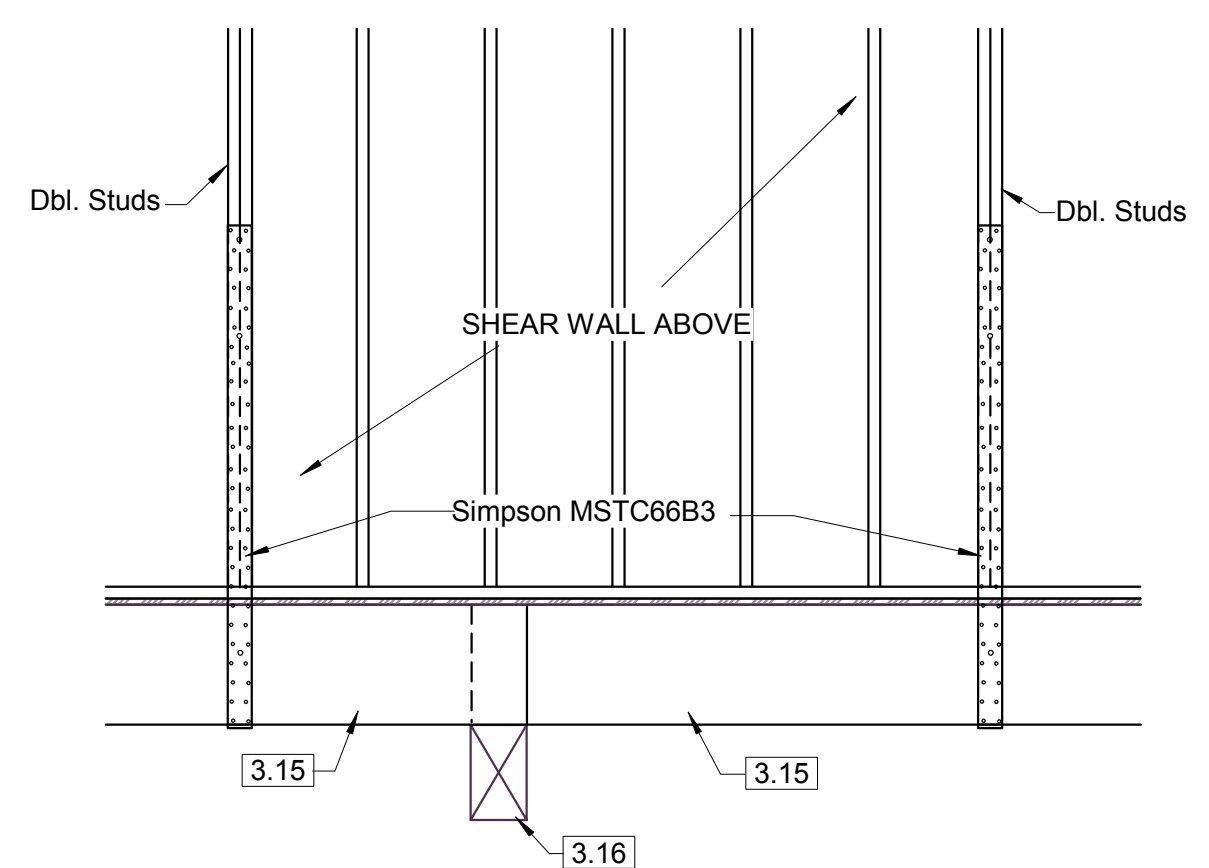

DETAIL 20 SCALE: 1/2" = 1'-0" (1:24)

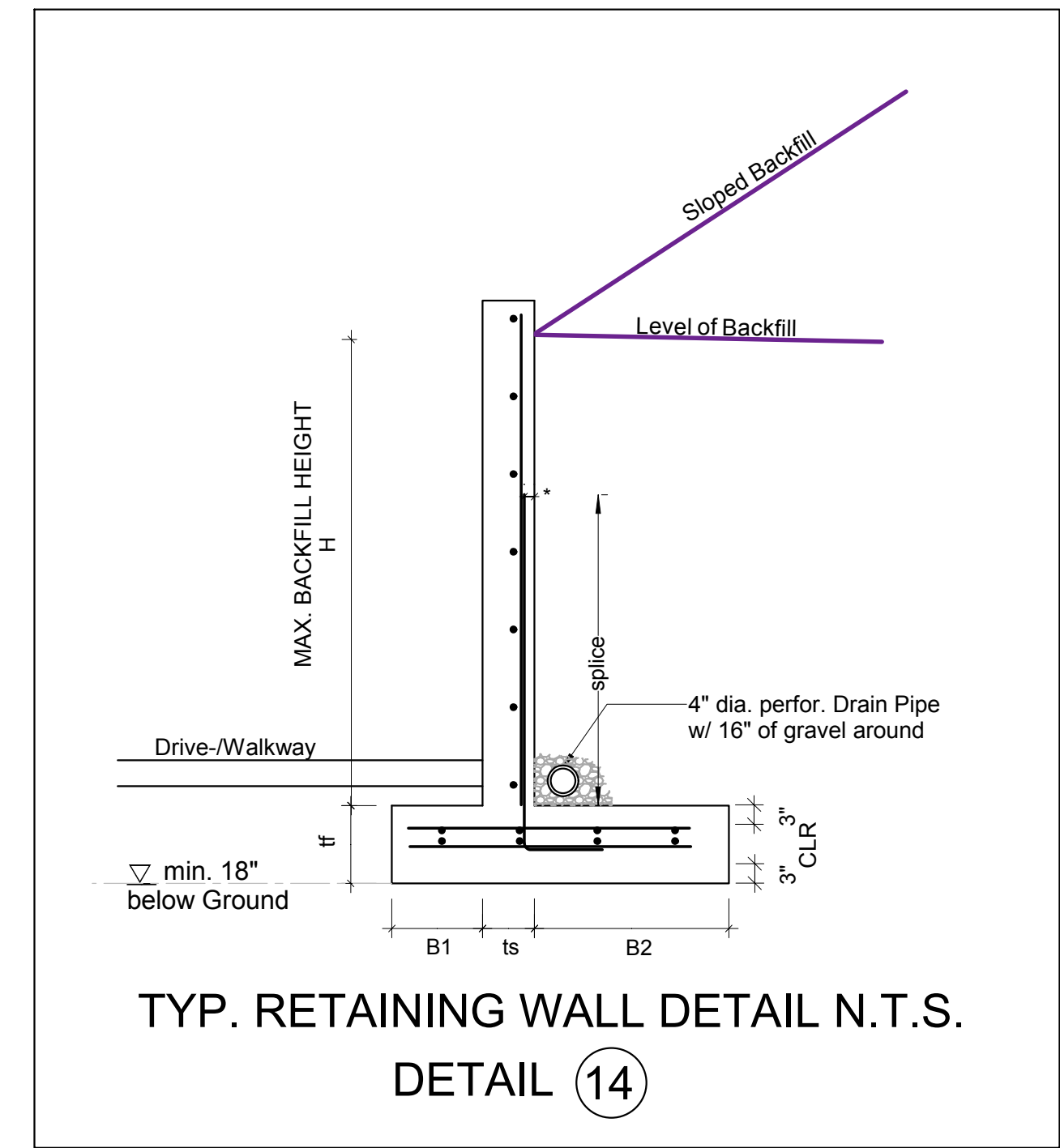

TYP. RETAINING WALL DETAIL N.T.S.
DETAIL 14

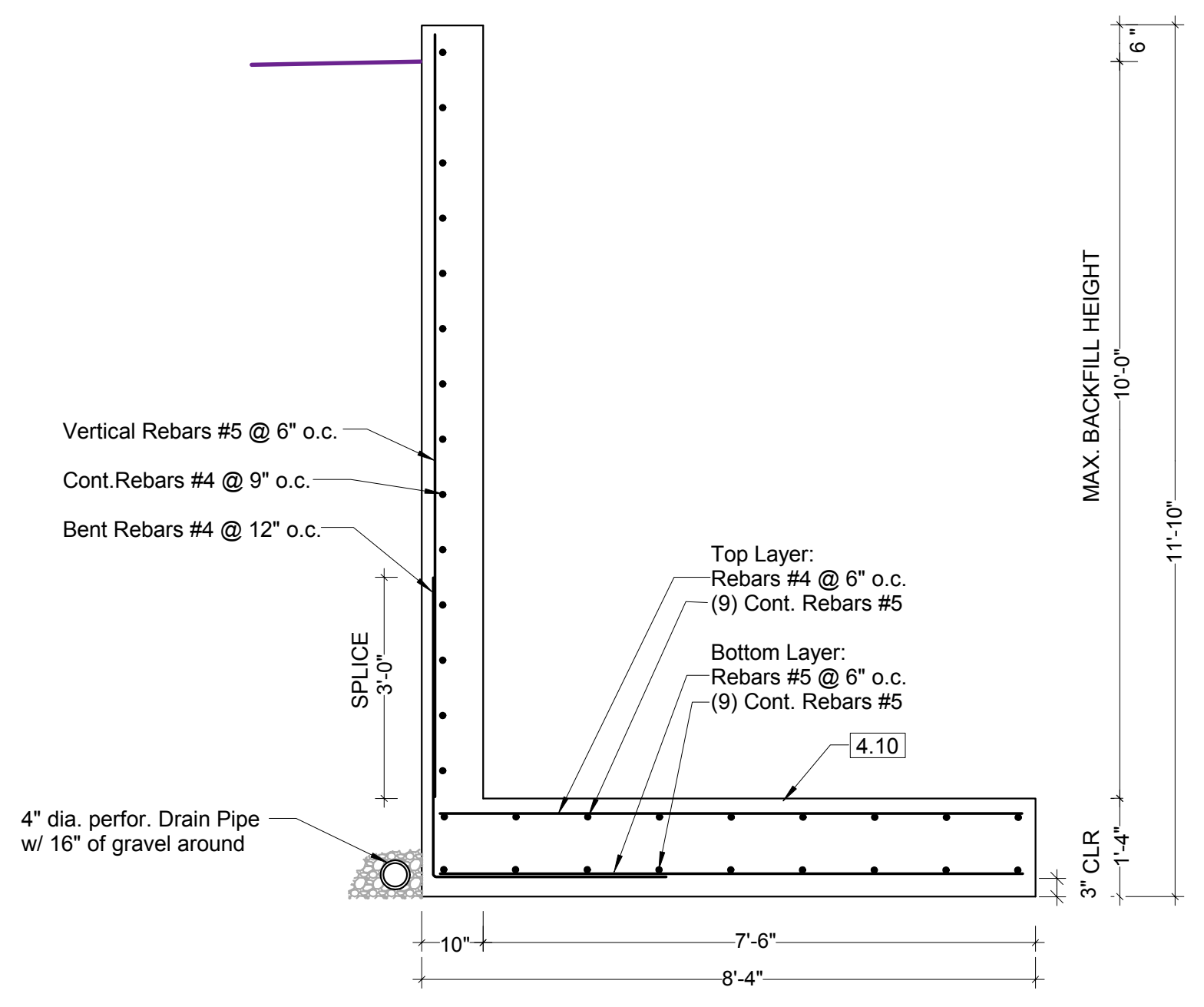

DETAIL 22 SCALE: 1/2" = 1'-0" (1:24)

| PROTECTION FOR REINFORCEMENT OF CAST IN-PLACE CONCRETE | MIN. COVER |
|--|------------|
| Concrete cast against and permanently exposed to earth | 3" |
| Concrete exposed to earth or weather | |
| * Wall panels: | |
| No. 6 through No. 18 bars | 2" |
| No. 5 bars, W31 or D31 wire, and smaller | 1 1/2" |
| Concrete exposed to neither earth or weather | |
| Slabs, walls, and joists: | |
| No. 14 and no. 18 bars | 1 1/2" |
| No. 11 and smaller bars | 3/4" |
| Beams and Columns: | |
| Primary reinforcement, ties, stirrups, and spirals | 1 1/2" |
| Shells and folded-plate members: | |
| No. 6 bars and larger | 3/4" |
| No. 5 bars, W31 or D31 or smaller | 3/4" |

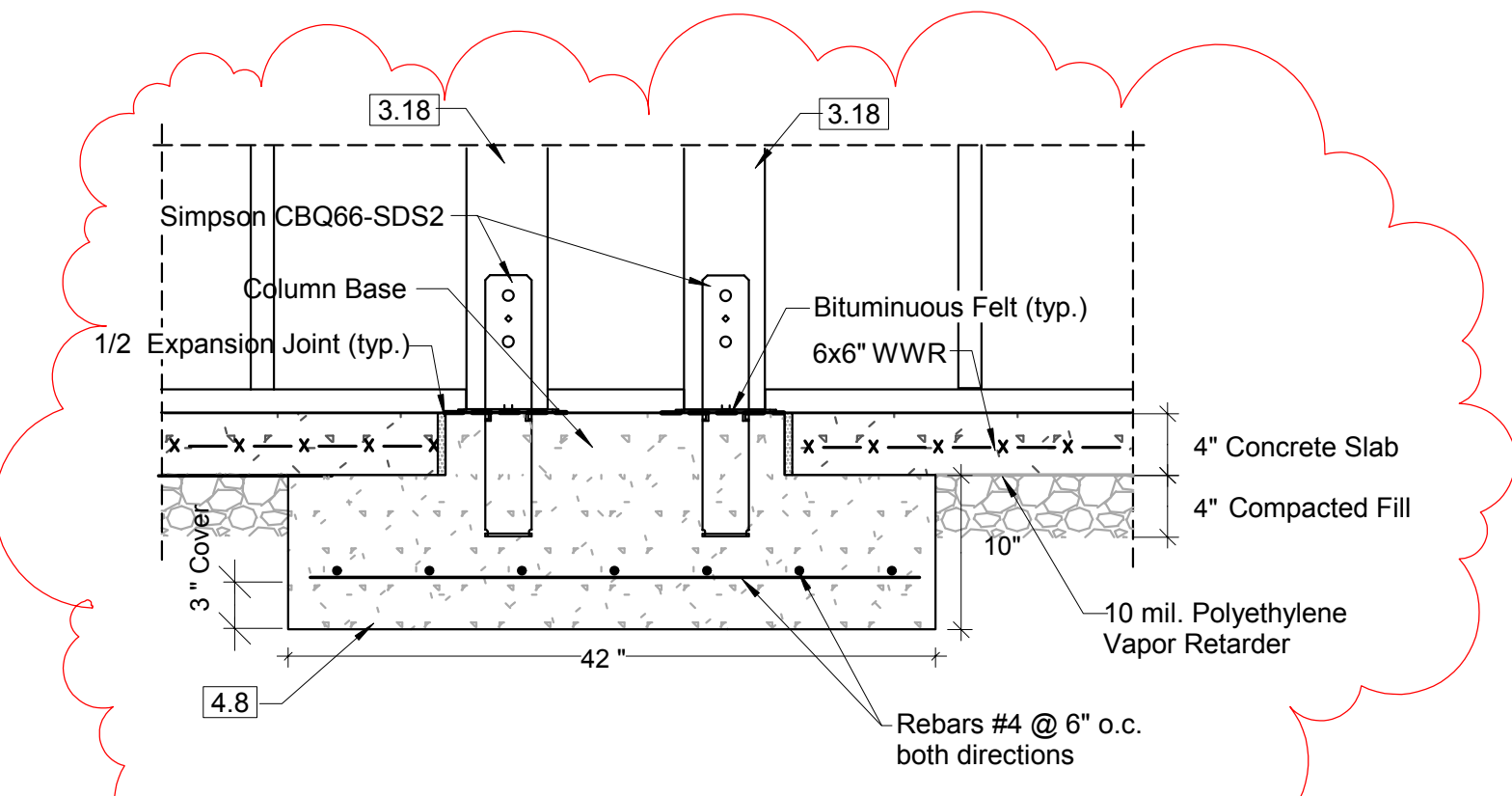

DETAIL 17 SCALE: 1" = 1'-0" (1:12)



REVISION 06/18/17

| | | |
|--|----------------------------------|-----------------|
| tecinstruct LLC 6830 NE Bothell Way - Suite C, PMB 181, Kenmore, WA 98028 Telephone (206) 553 9076 - Fax (206) 529 4408 | | |
| ENGINEERING | | |
| BUILDER: | Barcelo Homes | SHEET |
| JOB SITE: | 4634 E Mercer Way, Mercer Island | S2.1 |
| PARCEL NO.: | WA 98040 | |
| DESCRIPTION: | new SFR | |
| DATE: | 03/11/15 | SCALE: as noted |
| ENGINEER: | Roland Heimisch, P. E. | |

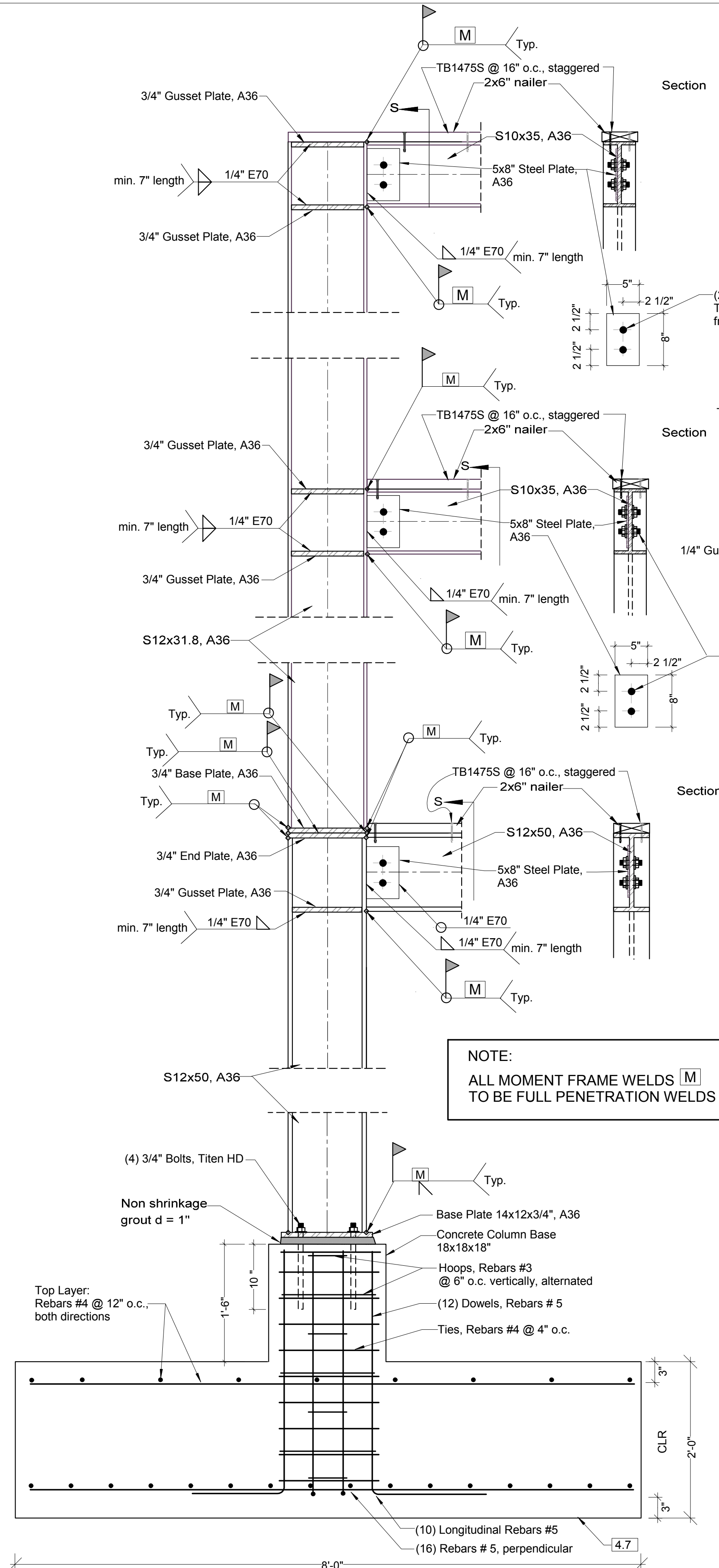

DETAIL 1
MOMENT FRAME SCALE: 1" = 1'-0" (1:12)

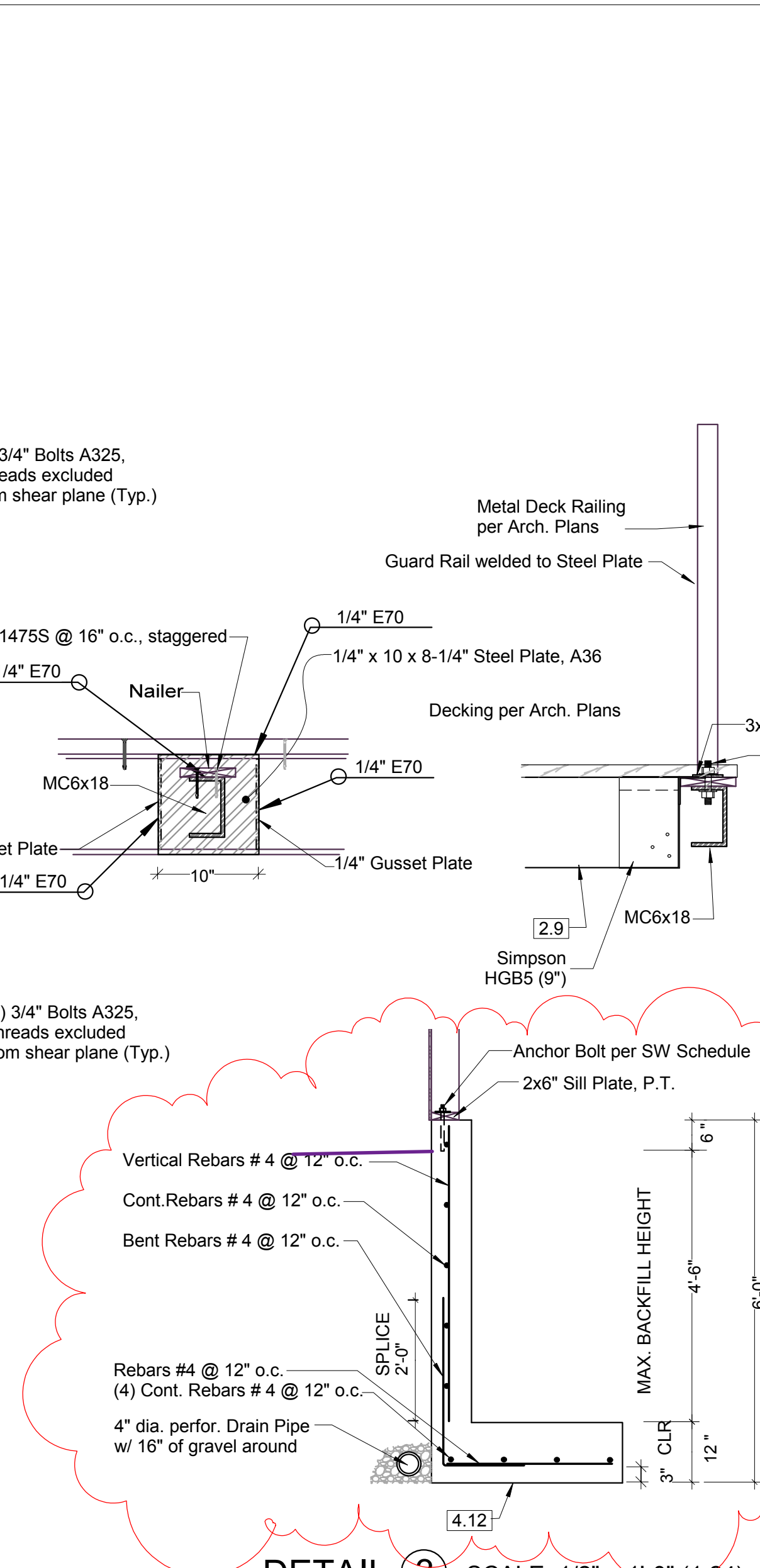

DETAIL 3 SCALE: 1/2" = 1'-0" (1:24)

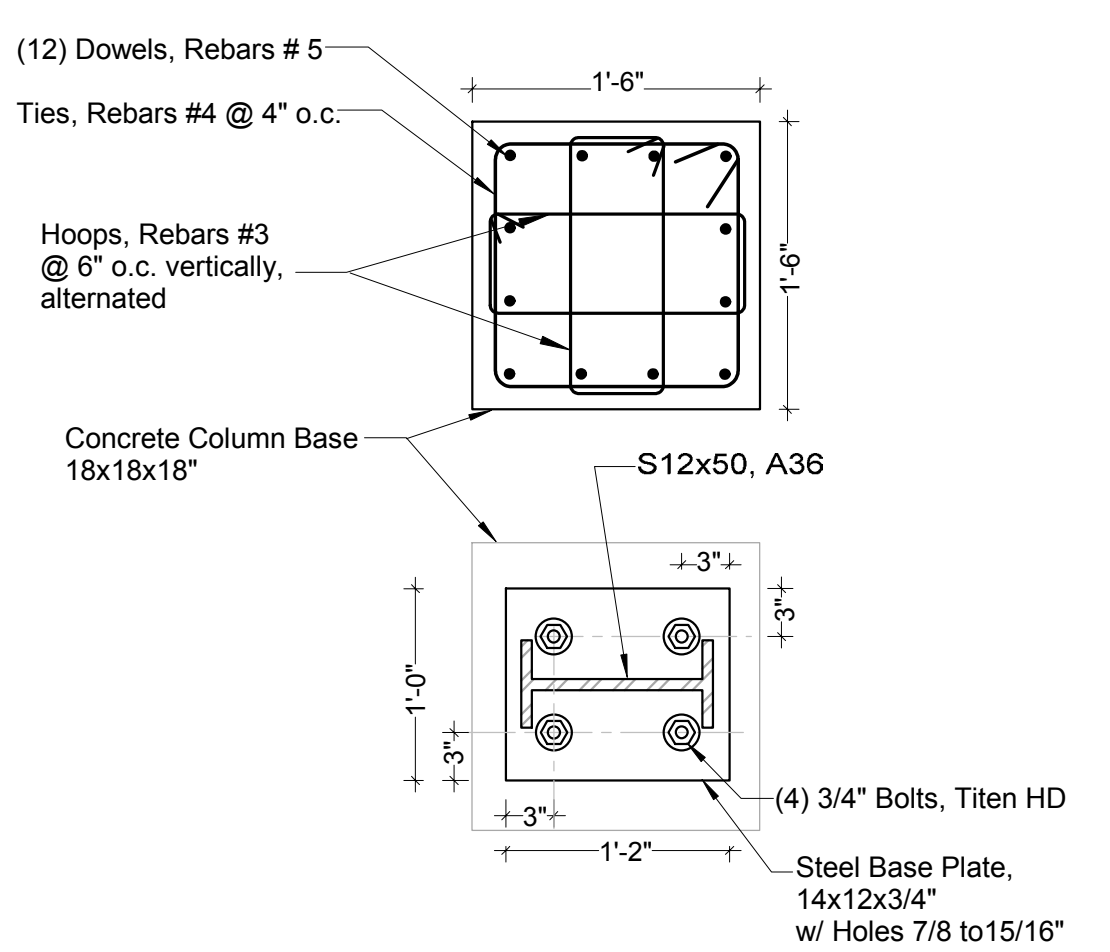

MOMENT FRAME COLUMN BASE
 SCALE: 1" = 1'-0" (1:12)

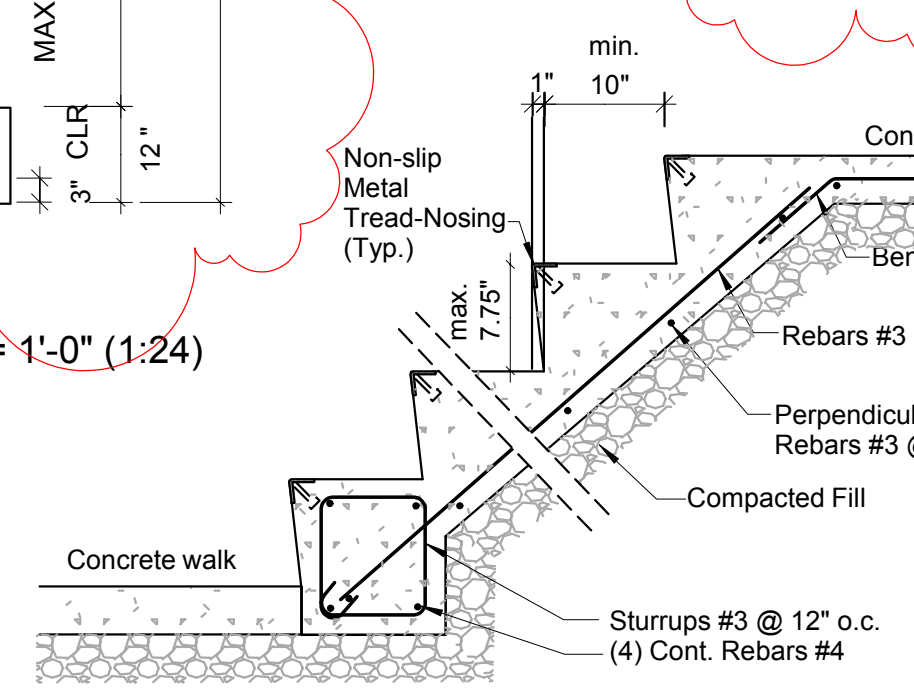

CONCRETE STAIRS (TYP)
 SCALE: 3/4" = 1'-0" (1:16)



MOMENT FRAME ELEVATION M-M SCALE: 1/4" = 1'-0" (1:48)

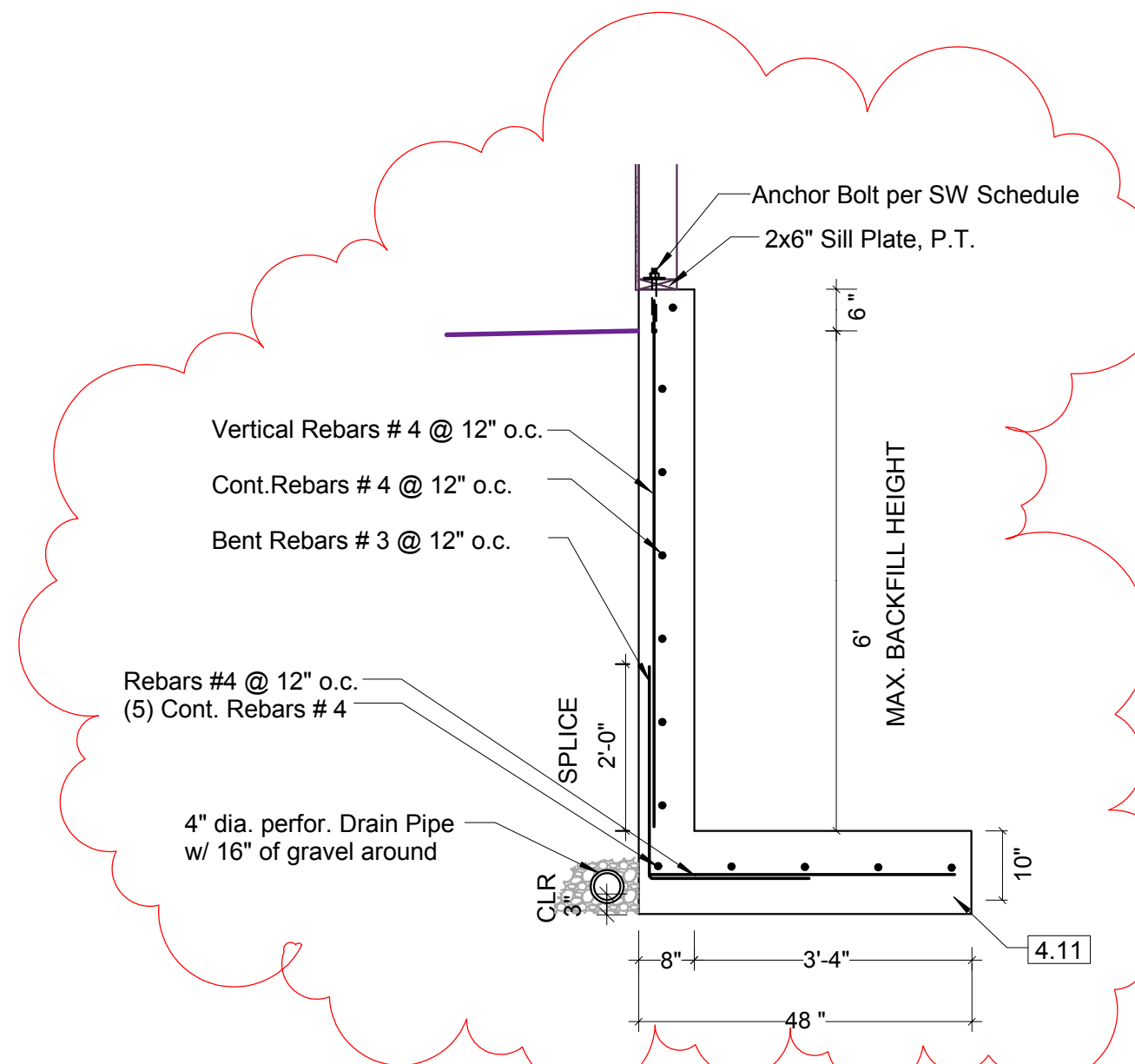

DETAIL 2
 SCALE: 1/2" = 1'-0" (1:24)



REVISION 06/18/17

| | | |
|--|----------------------------------|-----------------|
| tec instruct LLC | | S3 |
| 6830 NE Bothell Way - Suite C, PMB 181, Kenmore, WA 98028 Telephone (206) 553 9076 - Fax (206) 529 4408 ENGINEERING | | |
| BUILDER: | Barcelo Homes | SHEET |
| JOB SITE: | 4634 E Mercer Way, Mercer Island | |
| PARCEL NO.: | WA 98040 | |
| DESCRIPTION: | new SFR | |
| DATE: | 03/11/15 | SCALE: as noted |
| ENGINEER: | Roland Heimisch, P. E. | |

| KEY NO. | STRUCTURAL MEMBERS | REACTIONS | | | |
|-------------------------------------|--|-----------|-------|-------------------------|----------|
| | | DL | LL | CANTILEVER (-) = uplift | rear end |
| FLOOR SYSTEM ABOVE 2ND LEVEL | | | | | |
| 2.1 | TJI 360, 2-5/16x11-7/8" @ 12" o.c. | | | | |
| 2.2 | TJI 360, 2-5/16x11-7/8" @ 16" o.c. | | | | |
| 2.2a | TJI 360, 2-5/16x11-7/8" @ 16" o.c. | | | | |
| 2.3 | TJI 210, 2-1/16x11-7/8" @ 16" o.c. | | | | |
| 2.4 | TJI 210, 2-1/16x11-7/8" @ 16" o.c. | | | | |
| 2.5 | Deck Joists, HF No.2, 2x8" @ 16" o.c. P.T. | | | | |
| 2.6 | Beam, Glulam WS, 24F-1.8E, 6-3/4x24" | 5,016 | 9,100 | | |
| 2.7 | Beam, PSL, 2.0E, 2900Fb, 5-1/4x11-7/8" | 1,534 | 2,736 | | |
| 2.8 | Beam, PSL, 2.0E, 2900Fb, 5-1/4x11-7/8" | 3,040 | 3,931 | | |
| 2.9 | Beam @ Deck, Glulam WS, 24F-1.8E, 5-1/8x9" | 636 | 1,370 | | |
| 2.10 | Beam, Glulam WS, 24F-1.8E, 6-3/4x12" | 1,056 | 2,194 | -1,250 | |
| 2.11 | Beam, PSL, 2.0E, 2900Fb, 3-1/2x11-7/8" | 955 | 1,688 | -415 | 85 |
| 2.12 | Beam, PSL, 2.0E, 2900Fb, 3-1/2x11-7/8" | 2,574 | 2,604 | | |
| 2.13 | Beam, Glulam WS, 24F-1.8E, 5-1/4x12" | 1,950 | 1,733 | | |
| 2.14 | Header (=Rim), LSL, 1.55E, 2325Fb, 3-1/2x11-7/8" | | | | |
| 2.15 | Column, PSL, 1.8E, 5-1/4x5-1/4" | | | | |

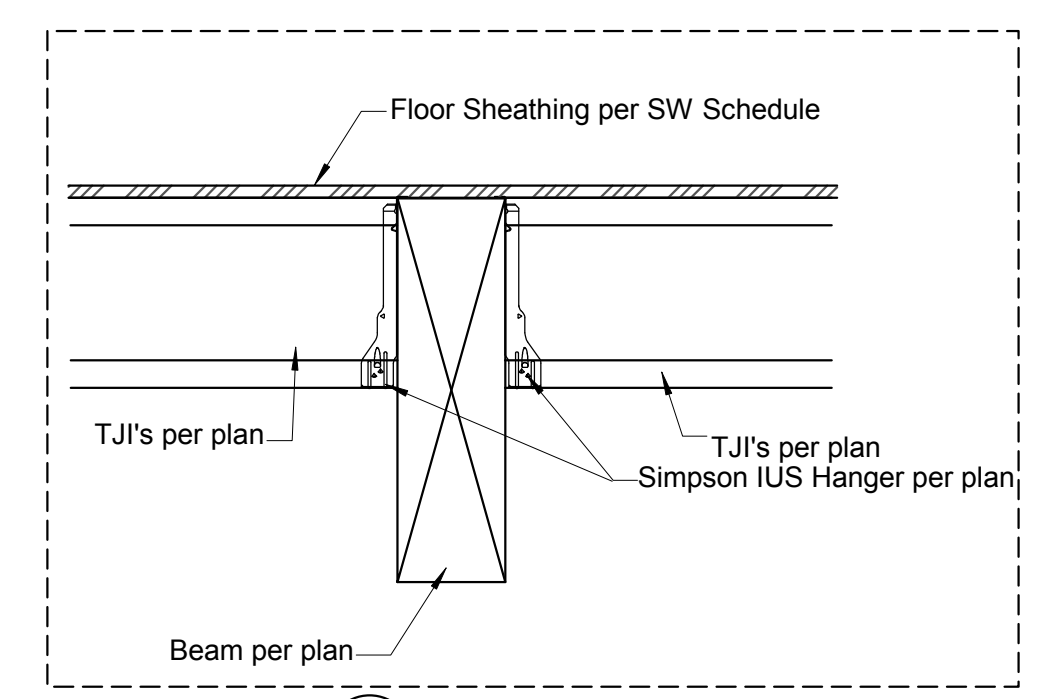

DETAIL 16 SCALE: 1" = 1'-0" (1:12)
TJI'S TO BEAM (TYP.)

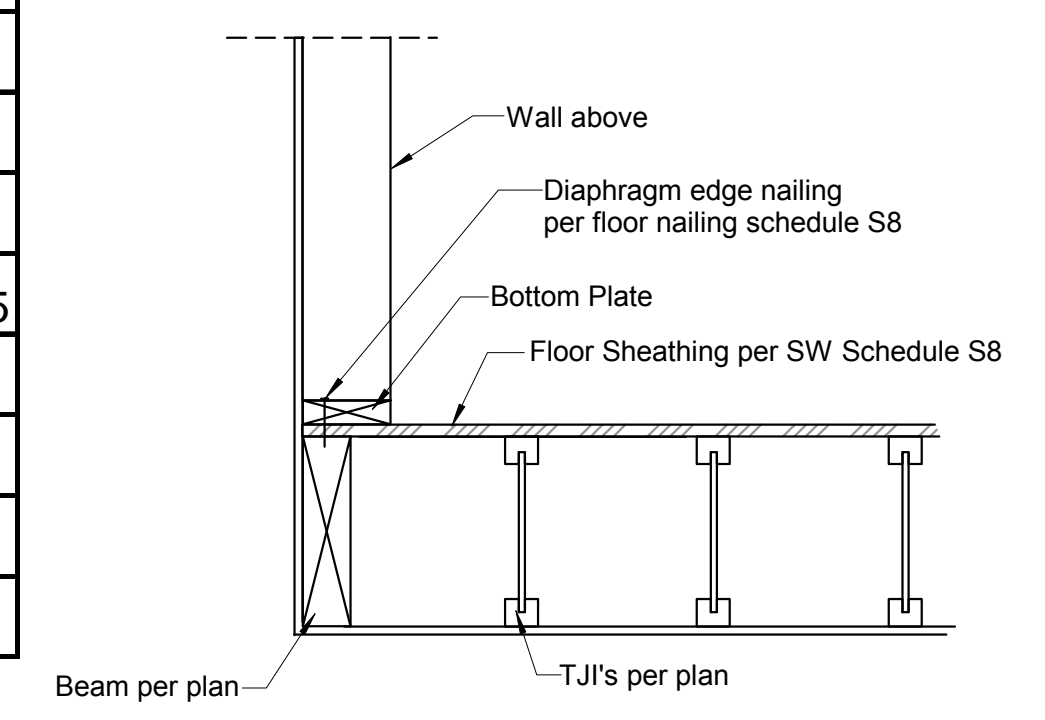

DETAIL 19 SCALE: 1" = 1'-0" (1:12)

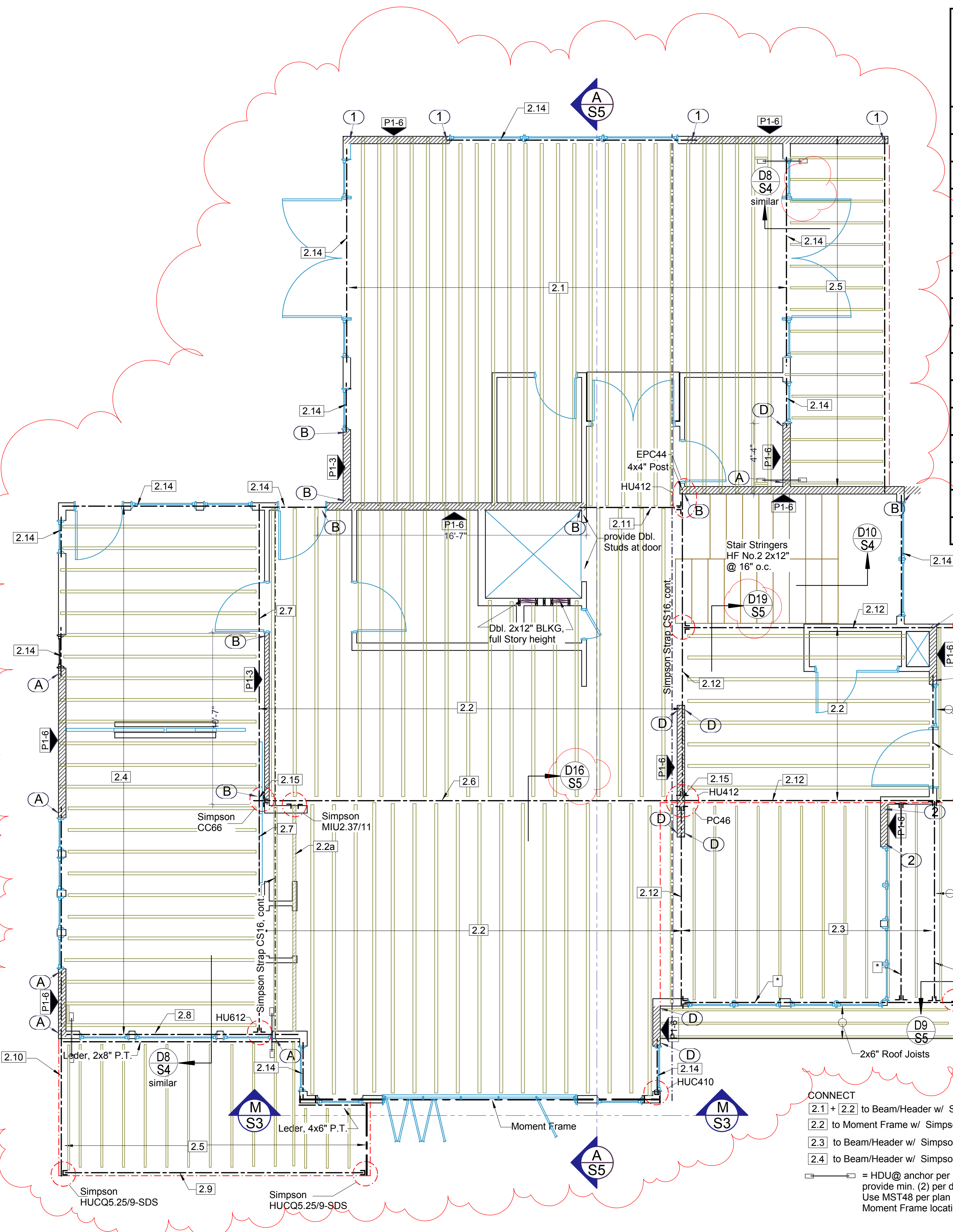

FRAMING ABOVE 2ND LEVEL SCALE: 1/4" = 1'-0" (1:48)

NOTE:
WHERE DETAILS ARE NOT SPECIFICALLY INDICATED BUT ARE OF SIMILAR CHARACTER TO DETAILS SHOWN, SIMILAR DETAILS OF CONSTRUCTION SHALL BE USED.

- CONNECT
- [2.1] + [2.2] to Beam/Header w/ Simpson IUS2.37/11.88
 - [2.2] to Moment Frame w/ Simpson LBV2.37/11.88
 - [2.3] to Beam/Header w/ Simpson U210
 - [2.4] to Beam/Header w/ Simpson IUS2.06/11.88
- = HDU@ anchor per D8/S5, provide min. (2) per deck; Use MST48 per plan at Moment Frame location.

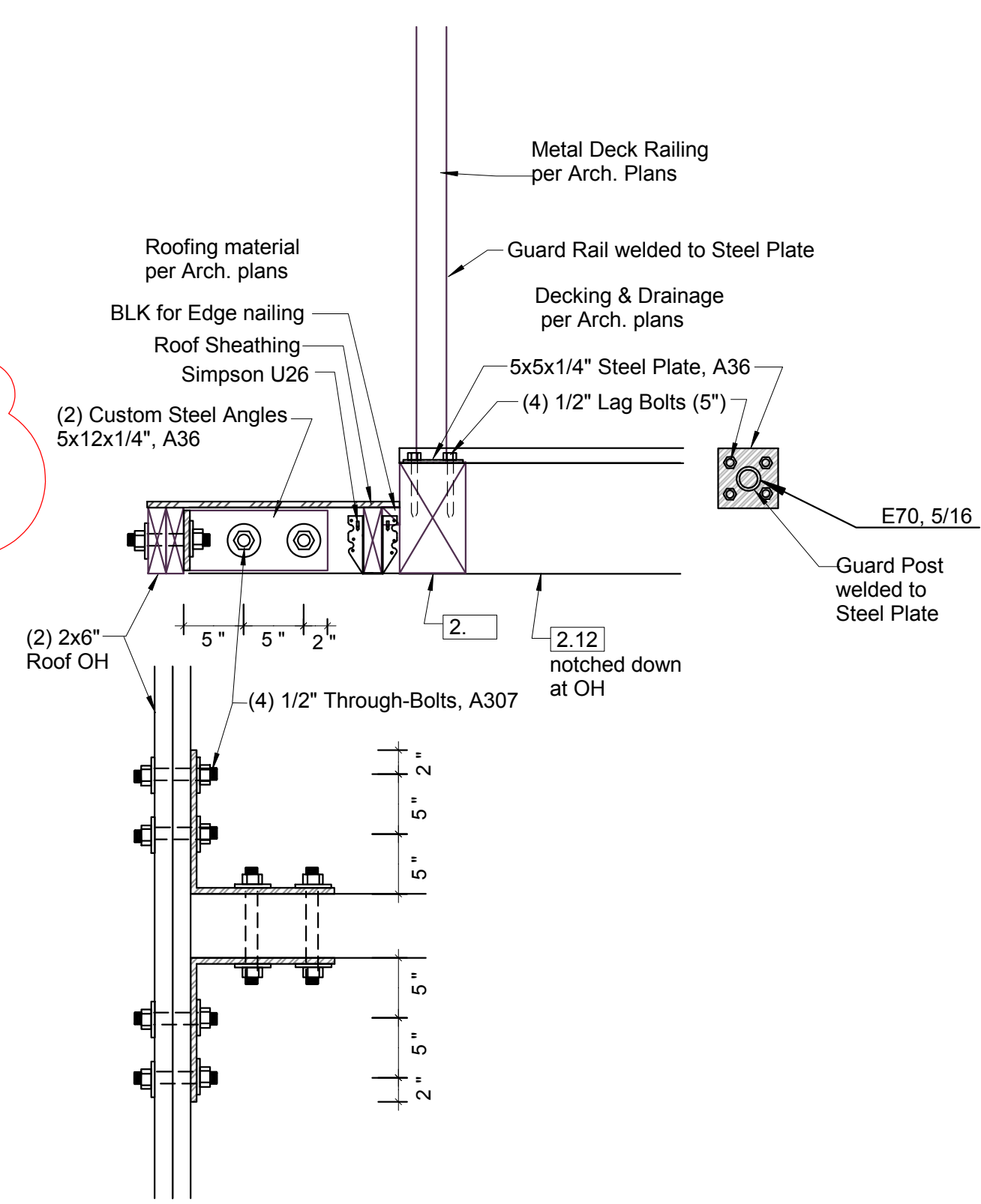

DETAIL 9 SCALE: 1" = 1'-0" (1:12)



REVISION 06/18/17

| | | |
|--|----------------------------------|--------------------|
| tec instruct LLC 6830 NE Bothell Way - Suite C, PMB 181, Kenmore, WA 98028 Telephone (206) 553 9076 - Fax (206) 529 4408 | | SHEET S5 |
| ENGINEERING | | |
| BUILDER: | Barcelo Homes | SHEET S5 |
| JOB SITE: | 4634 E Mercer Way, Mercer Island | |
| PARCEL NO.: | WA 98040 | |
| DESCRIPTION: | new SFR | |
| DATE: | 03/11/15 SCALE: as noted | |
| ENGINEER: | Roland Heimisch, P. E. | |

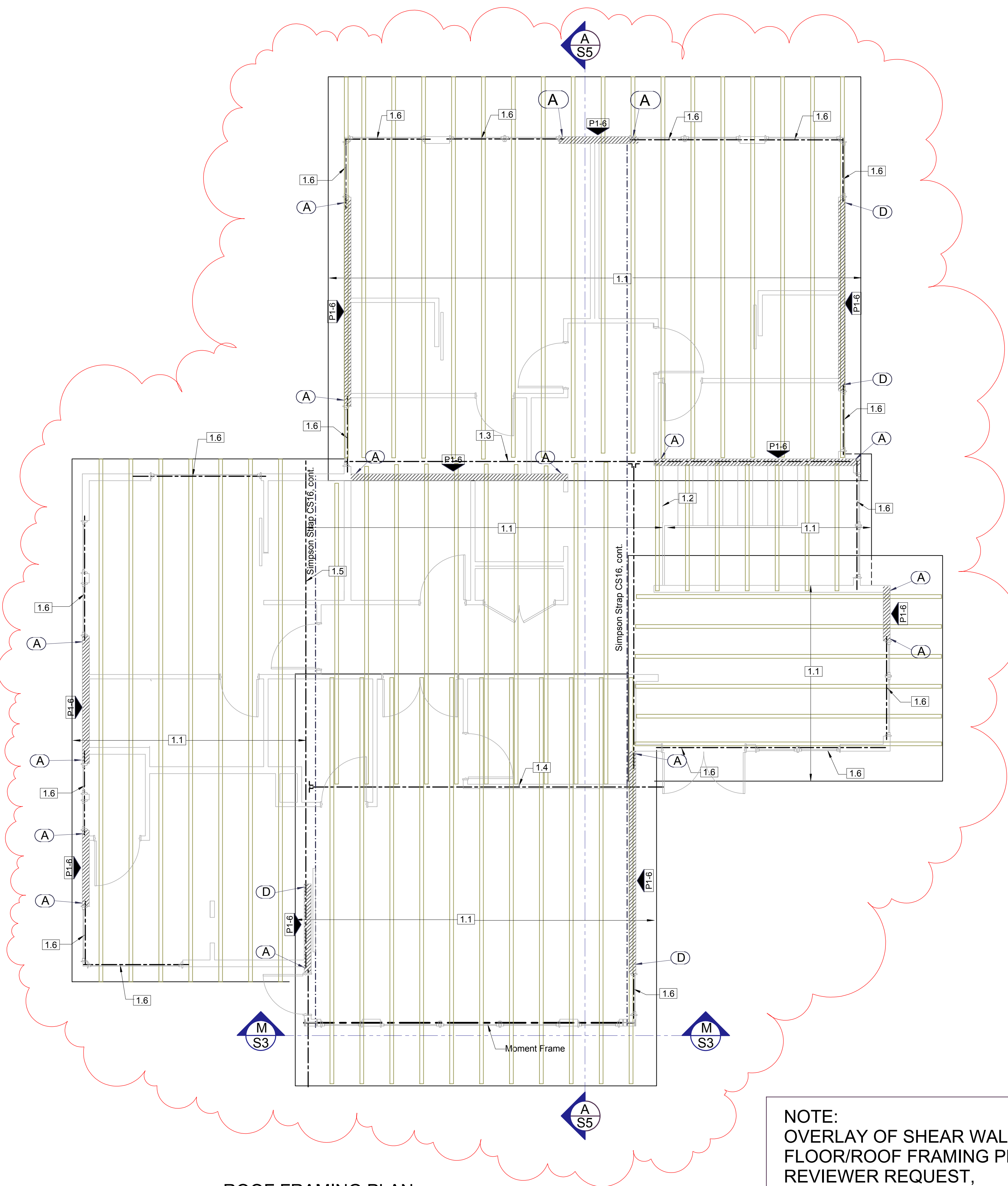

ROOF FRAMING PLAN SCALE: 1/4" = 1'-0" (1:48)

NOTE:
 OVERLAY OF SHEAR WALLS IN
 FLOOR/ROOF FRAMING PLANS PER
 REVIEWER REQUEST,
 REFER TO SHEAR WALL PLANS (S8/S9)
 FOR SHEAR WALL INFORMATION

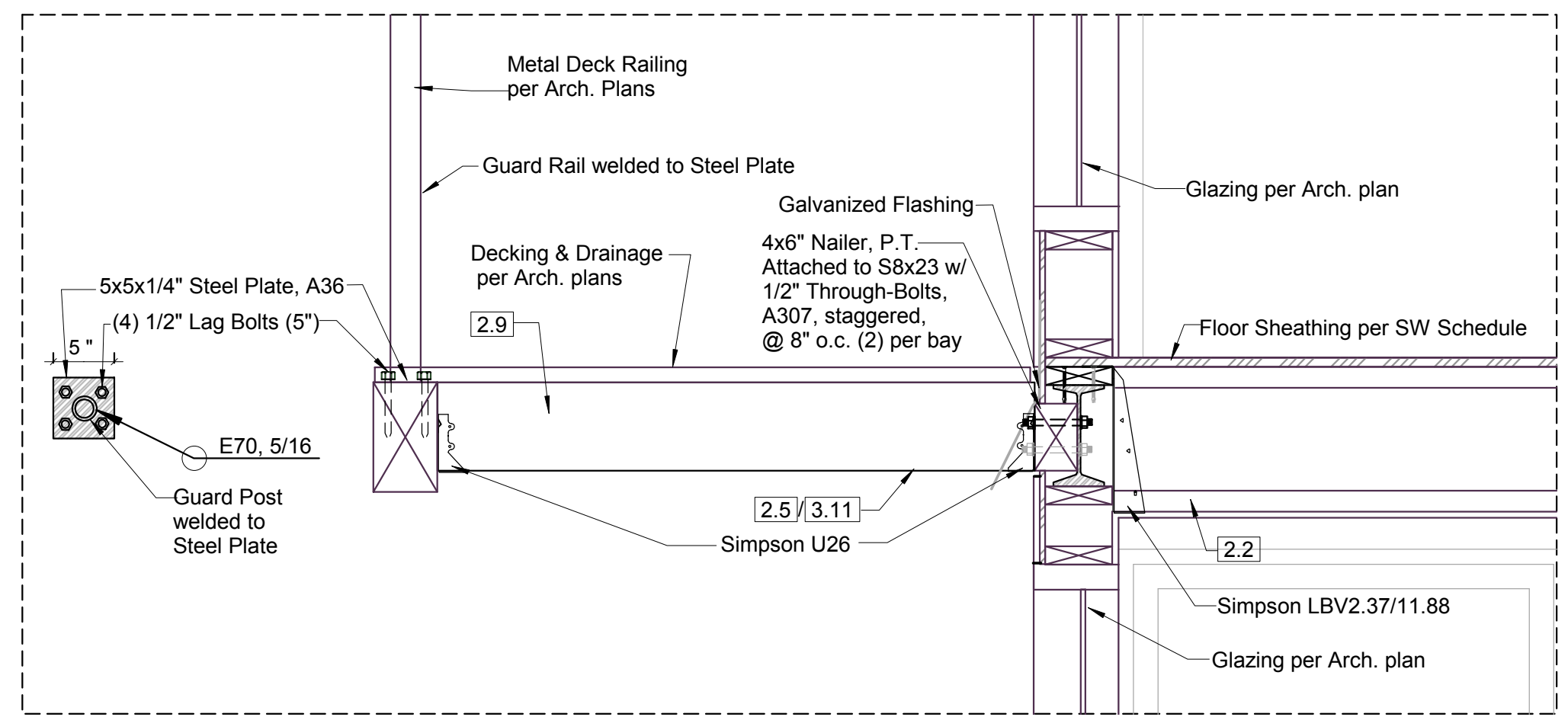

DETAIL 4 SCALE: 1" = 1'-0" (1:12)

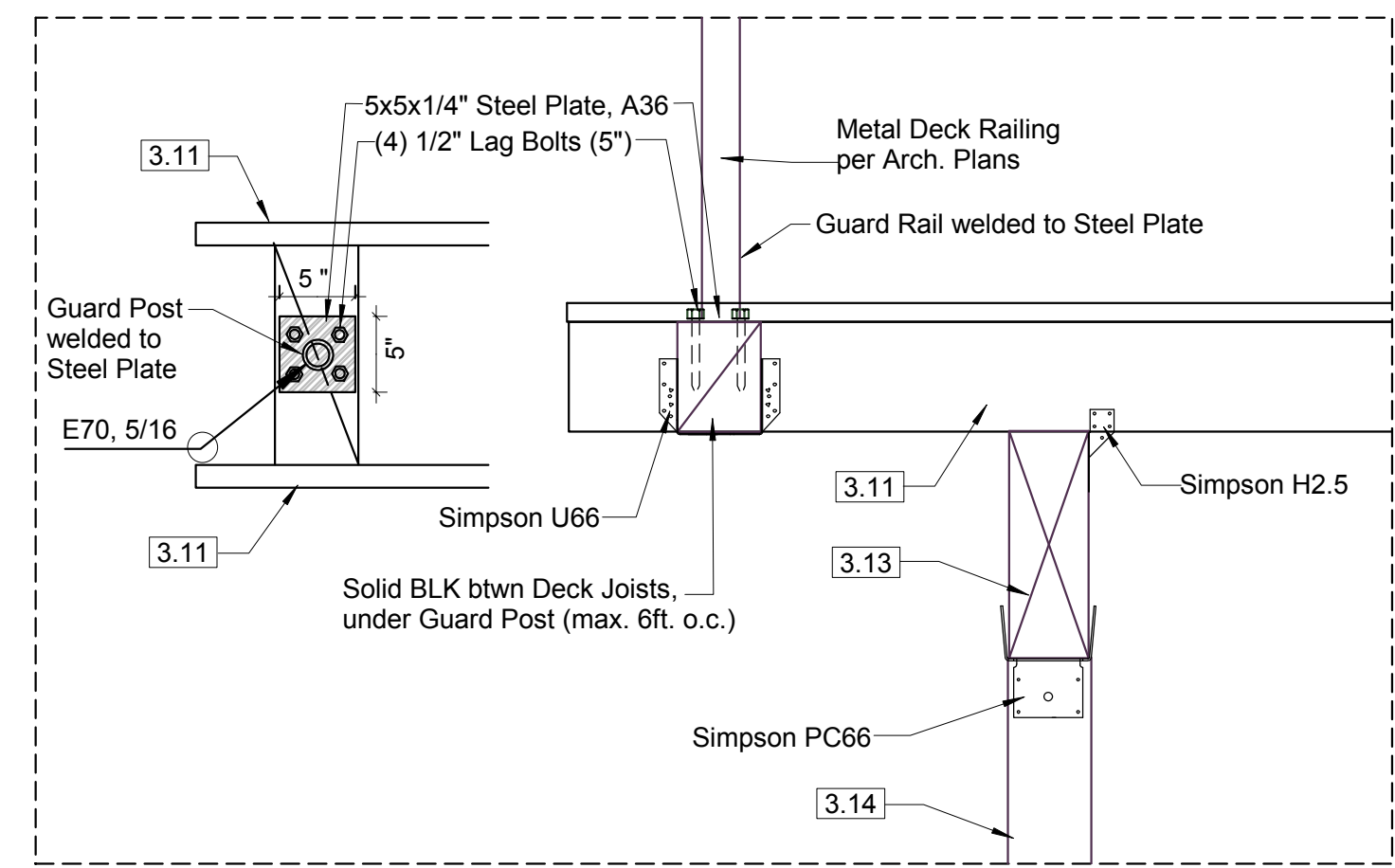

DETAIL 5 SCALE: 1" = 1'-0" (1:12)

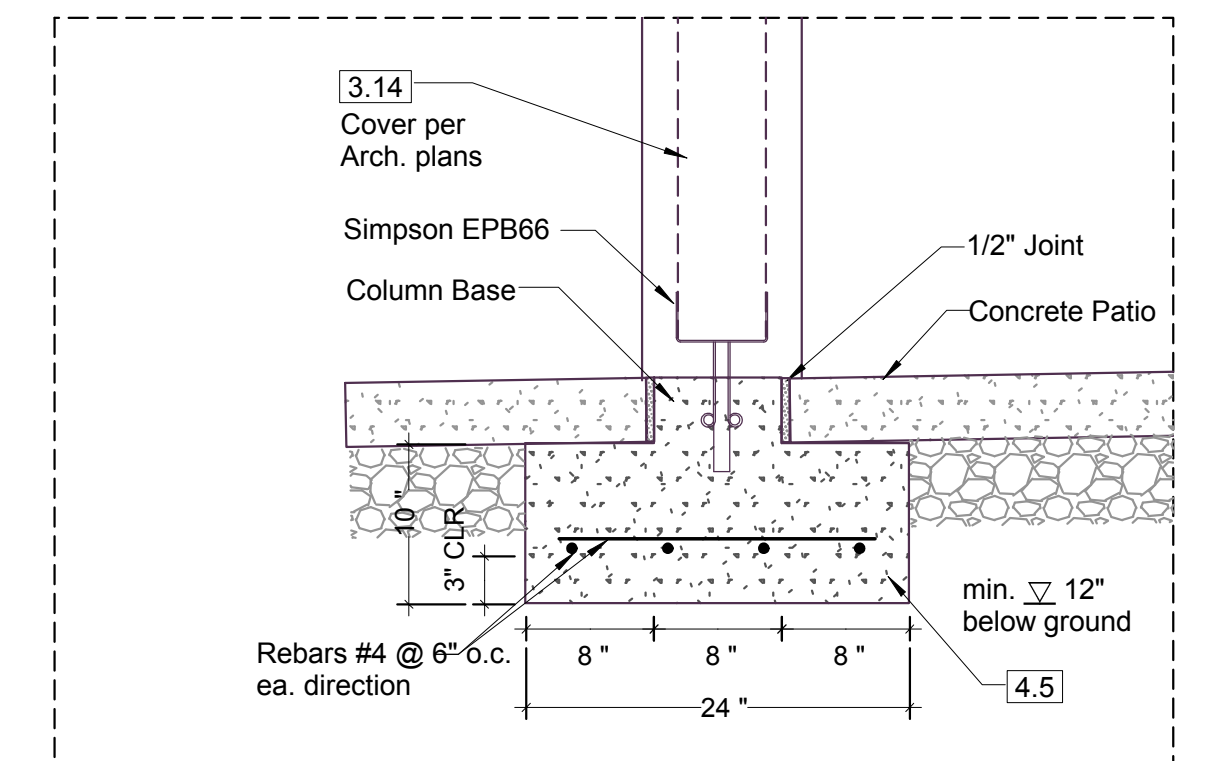

DETAIL 6 SCALE: 1" = 1'-0" (1:12)

| KEY NO. | STRUCTURAL MEMBERS |
|-------------------|--|
| ROOF LEVEL | |
| 1.1 | Open Web Trusses @ 24" o.c., d = 18" |
| 1.2 | Girder Truss, d = 18" |
| 1.3 | Girder Truss, d = 18" |
| 1.4 | Girder Truss, d = 18" |
| 1.5 | Girder Truss, d = 18" |
| 1.6 | Header (=Rim), LVL, 2-ply, (2) 1-3/4x18" |



REVISION 06/18/17

| | | |
|---|----------------------------------|-----------------|
| | | S7 |
| 6830 NE Bothell Way - Suite C, PMB 181, Kenmore, WA 98028 Telephone (206) 553 9076 - Fax (206) 529 4408 ENGINEERING | | |
| BUILDER: | Barcelo Homes | SHEET |
| JOB SITE: | 4634 E Mercer Way, Mercer Island | |
| PARCEL NO.: | WA 98040 | |
| DESCRIPTION: | new SFR | |
| DATE: | 02/23/15 | SCALE: as noted |
| ENGINEER: | Roland Heimisch, P. E. | |

HOLDOWN SCHEDULE

| SYMBOL | HOLDOWN | EMBED. | BOLT TYPE | MIN. WOOD MEMBER THICKNESS |
|--------|---------------|--------|-----------|----------------------------|
| ① | Simpson HDU2 | 18" | SB5/8x24 | (2) 2x |
| ② | Simpson HDU4 | 18" | SB5/8x24 | (2) 2x |
| ③ | Simpson HDU8 | 18" | SB7/8x24 | DF 6x6" |
| ④ | Simpson HDU11 | 24" | SB1x30 | DF 6x6" |

VERTICAL DIAPHRAGM

| SHEARWALL TYPE | WALL SHEATHING (PANEL) THICKNESS & GRADE | SPAN INDEX | NAIL TYPE | NAILING | | WALL STUD GRADE & SPACING | BLKG REQ'D | BLOCK SIZE | ABUTTING PLYWOOD PANEL EDGE MEMBER SIZE | TOP PLATE NAILING SIZE & SPACING | SOLE PLATE NAILING SIZE & | FOUNDATION ANCHOR BOLTS SIZE & SPACING | ALLOWABLE LOAD SEISMIC / WIND | SIMPSON CLIPS |
|-------------------|--|------------|-----------|---------|----------|---------------------------|------------|------------|---|----------------------------------|---------------------------|--|-------------------------------|-----------------|
| | | | | EDGE | FIELD | | | | | | | | | |
| P1-6 | 15/32" APA RATED/OSB ONE FACE | 24/0 | 8d | 6" o.c. | 12" o.c. | HEM-FIR @ 16" o.c. | yes | 2x | 2x | 16d @ 5" | 16d @ 5" | 5/8" @ 48" o.c. | 244 PLF / 342 PLF | LTP5 @ 24" o.c. |
| P1-3 ² | 15/32" APA RATED/OSB ONE FACE | 24/0 | 8d | 3" o.c. | 12" o.c. | HEM-FIR @ 16" o.c. | yes | 3x | 3x | (2) ROWS 16d @ 4" | (2) ROWS 16d @ 4" | 5/8" @ 24" o.c. | 564 PLF / 790 PLF | LTP5 @ 12" o.c. |

NOTE:
For all non-Shear Walls use nailing pattern, bolt and clip size/spacing for P1-6

STRAP SCHEDULE

| SYMBOL | STRAP | WOOD MEMBER | NAILS |
|--------|----------|-------------|----------|
| Ⓐ | MST48 | (2) 2x | 34 - 16d |
| Ⓑ | MST60 | (2) 2x | 46 - 16d |
| Ⓒ | HTS20 | (2) 2x | 20 - 16d |
| Ⓓ | MSTC66B3 | (2) 2x | 38 - 10d |

HORIZONTAL DIAPHRAGM

| | THICKNESS & GRADE | SPAN INDEX | NAIL TYPE | NAILING | | |
|---------------|----------------------------|------------|-----------|---------|---------|----------|
| | | | | BDRY | EDGE | FIELD |
| FLOOR NAILING | 3/4" CDX T&G APA RATED/OSB | 48/24 | 10d | 6" o.c. | 6" o.c. | 12" o.c. |
| ROOF NAILING | 7/16" APA RATED/OSB | 24/0 | 8d | 6" o.c. | 6" o.c. | 12" o.c. |

SHEAR WALLS

- ALL SHEAR WALLS SHALL CONFORM TO IBC SECTION 23 REQMENTS. APPLY NAILING TO ALL STUDS, TOP AND BOTTOM PLATES AND BLOCKINGS. SHEATHING SHALL BE INSTALLED VERTICALLY W/ 4x10 SHEETS FROM THE SILL PLATE AT THE FOUNDATION TO THE LOWER OF THE DOUBLED TOP PLATES AT THE MAIN LEVEL AND FROM THE UPPER OF THE DOUBLED TOP PLATES AT THE WALL TO THE TOP OF THE DOUBLED TOP PLATES AT THE UPPER LEVEL.
- WHERE APA SHEATHING IS APPLIED ON BOTH FACES OF THE WALL AND NAIL SPACING IS LESS THAN 6" O.C. ON EITHER SIDE, PANEL JOINTS SHALL BE OFFSET TO FALL ON DIFFERENT FRAMING MEMBER, OR FRAMING SHALL BE 3x NOMINAL AND NAILS ON EACH SIDE SHALL BE STAGGERED. WHERE ALLOWABLE SHEAR VALUES EXCEED 350 PLF (NAIL SPACING 4" OR LESS, OR SHEAR WALLS W/ PLYWOOD APPLIED ON EACH SIDE OF THE STUD WALL) FOUNDATION SILL PLATES AND FRAMING ABUTTING PANEL EDGES SHALL BE 3x NOMINAL OR (2) 2x W/ STAGGERED NAILING.
- ABOVE LISTED ALLOWABLE SHEAR CAPACITIES ARE ADJUSTED FOR USE OF HEM-FIR STUDS, SPACED NO MORE THAN 16" O.C. AND SHEATHING APPLIED DIRECTLY TO FRAMING MEMBERS.
- 14 GAUGE STAPLES W/ 7/16" CROWN AND 2" NOMINAL LEG LENGTH OR 0.131 DIA. P-NAILS W/ 2" NOMINAL LENGTH CAN BE SUBSTITUTED FOR 8D COMMON NAILS W/ REDUCED SHEAR CAPACITIES TO USE STAPLES. VERIFY W/ ENGINEER.
- ALL FASTENERS SHALL BE DRIVEN FLUSH W/ SURFACE OF SHEATHING.
- PROVIDE A SINGLE JOIST OR MIN. 2x SOLID BLOCKING BELOW AND AT THE TOP OF ALL SHEARWALLS.

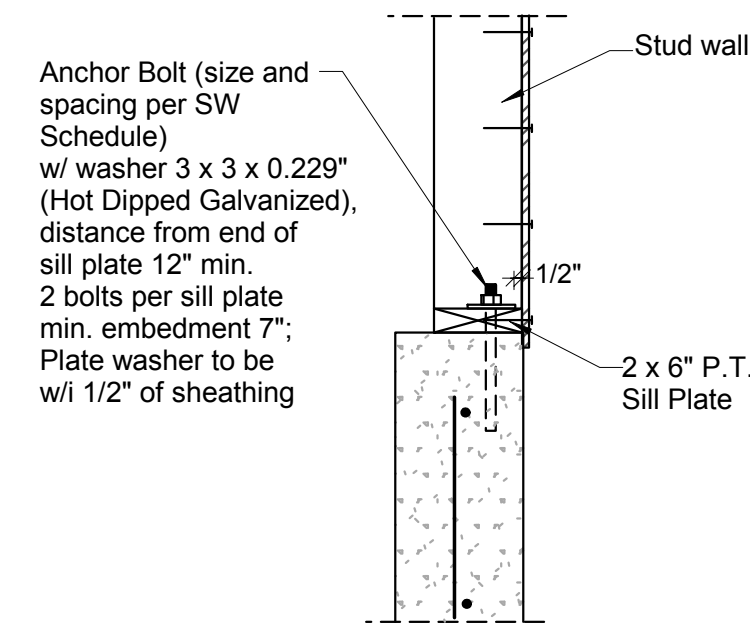

ANCHOR BOLT DETAIL (TYP.)
SCALE: 1" = 1'-0" (1:12)

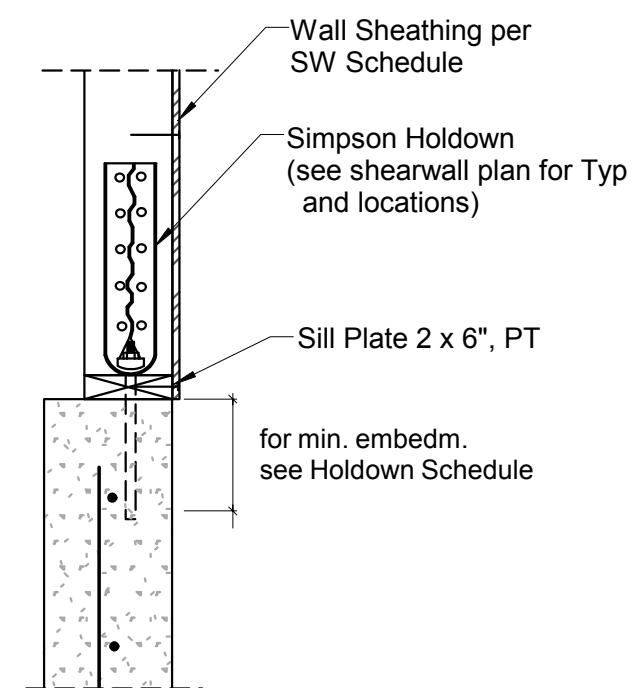

HOLDOWN DETAIL (TYP.)
SCALE: 1" = 1'-0" (1:12)

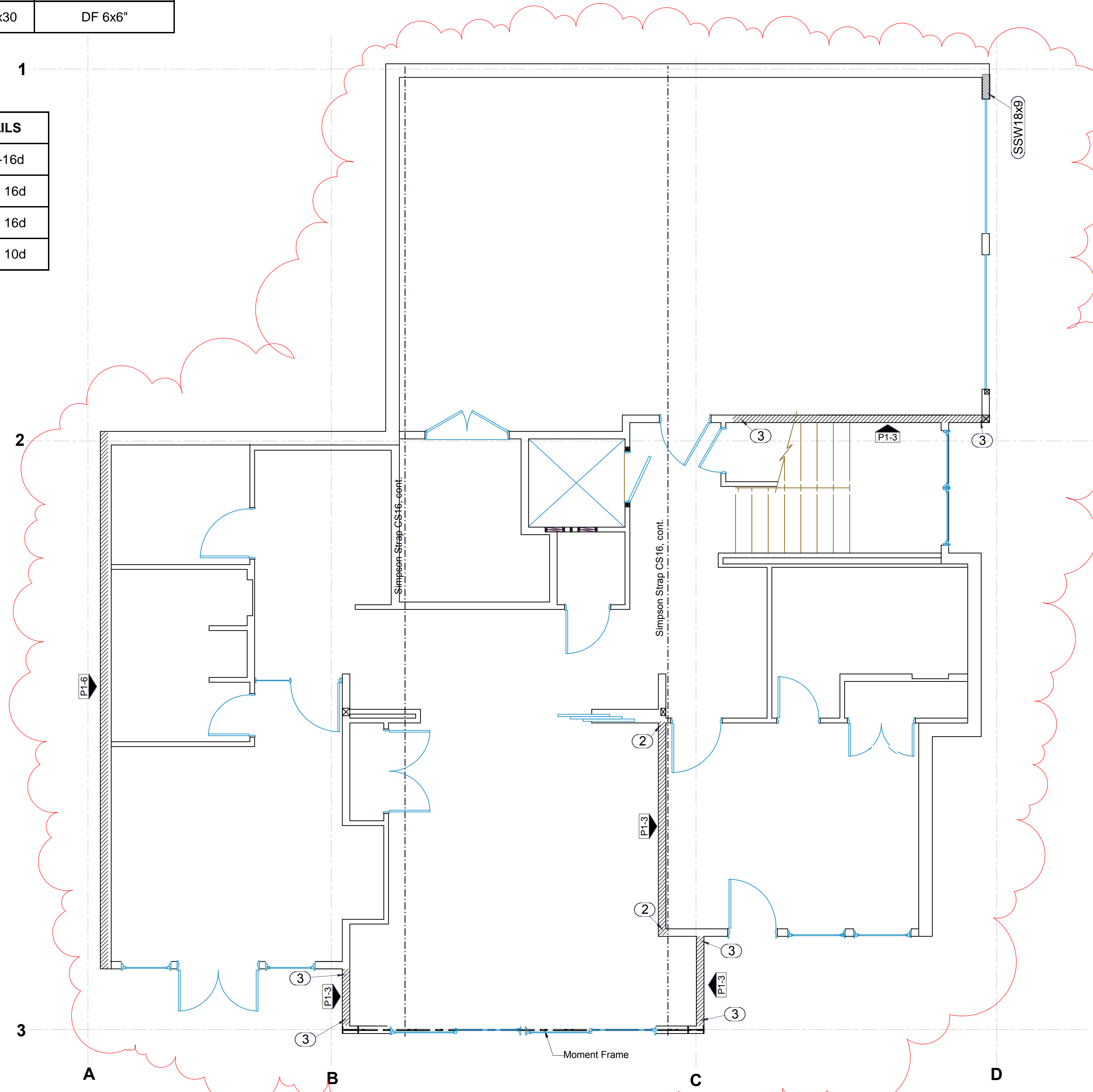

FIRST LEVEL SHEAR WALL PLAN SCALE: 1/4" = 1'-0" (1:48)



REVISION 06/18/17

| | | |
|---|----------------------------------|-----------------|
| tec instruct LLC 6830 NE Bothell Way - Suite C, PMB 181, Kenmore, WA 98028 Telephone (206) 553 9076 - Fax (206) 529 4408 ENGINEERING | | |
| BUILDER: | Barcelo Homes | SHEET |
| JOB SITE: | 4634 E Mercer Way, Mercer Island | S8 |
| PARCEL NO.: | WA 98040 | |
| DESCRIPTION: | new SFR | |
| DATE: | 02/23/15 | SCALE: as noted |
| ENGINEER: | Roland Heimisch, P. E. | |

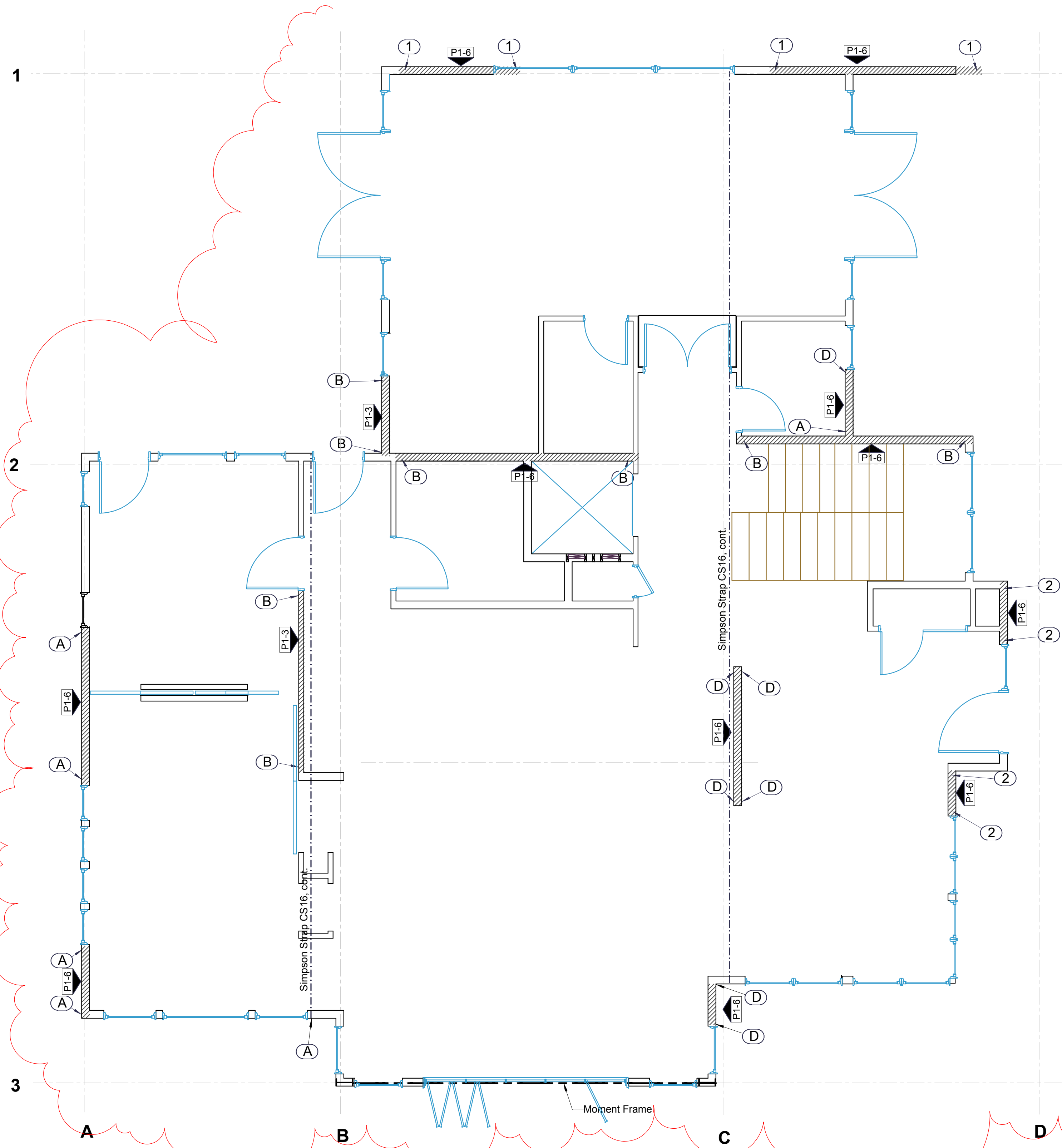

SECOND LEVEL SHEAR WALL PLAN

SCALE: 1/4" = 1'-0" (1:48)

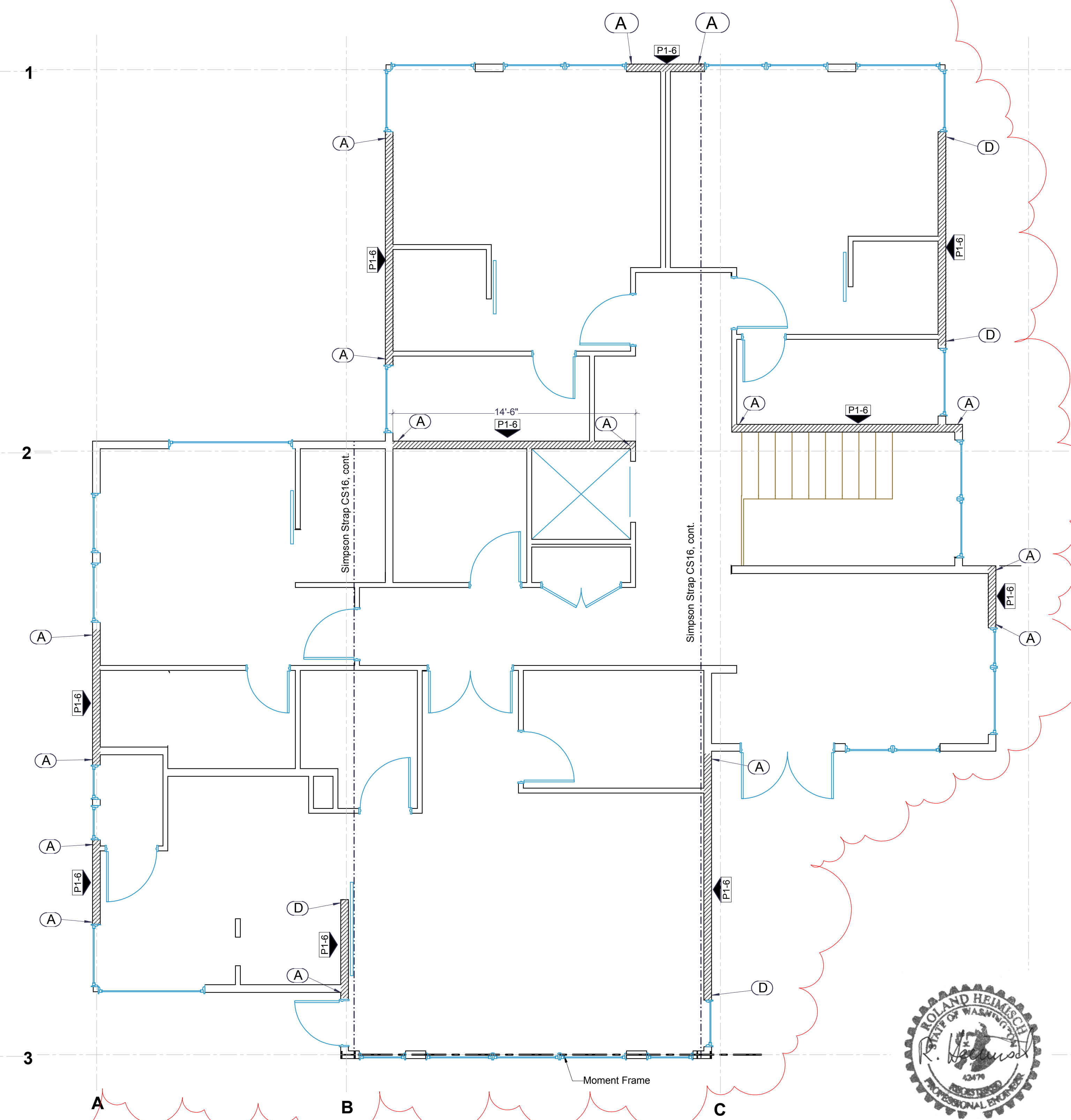

THIRD LEVEL SHEAR WALL PLAN

SCALE: 1/4" = 1'-0" (1:48)



REVISION 06/18/17

| | | |
|--|----------------------------------|-----------------|
| tec instruct LLC 6830 NE Bothell Way - Suite C, PMB 181, Kenmore, WA 98028 Telephone (206) 553 9076 - Fax (206) 529 4408 ENGINEERING | | |
| BUILDER: | Barcelo Homes | S9 |
| JOB SITE: | 4634 E Mercer Way, Mercer Island | |
| PARCEL NO.: | WA 98040 | |
| DESCRIPTION: | new SFR | |
| DATE: | 02/23/15 | SCALE: as noted |
| ENGINEER: | Roland Heimisch, P. E. | |

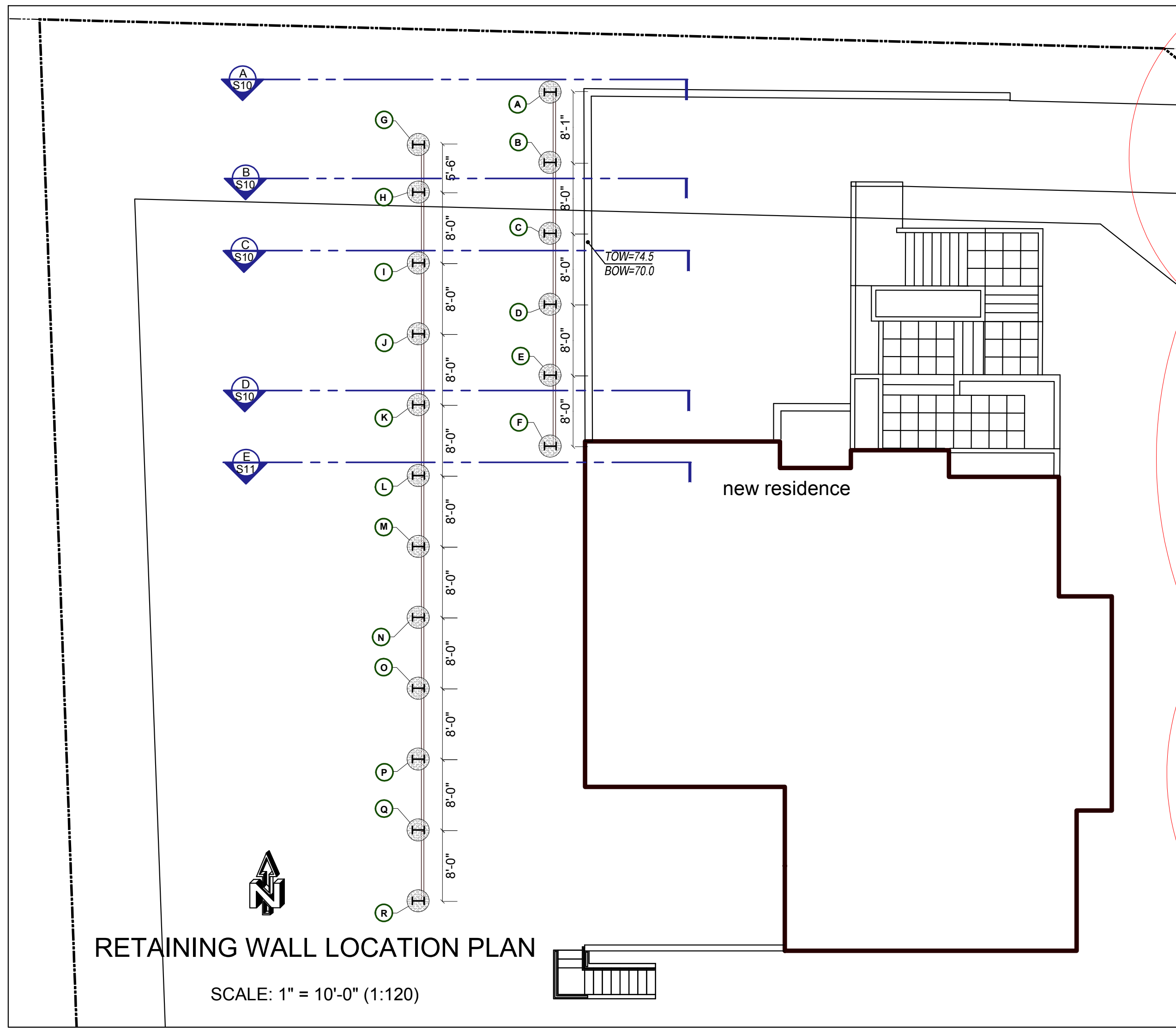

CONTRACTOR TO COORDINATE WITH ARCHITECT & STRUCTURAL ENGINEER ON ALL PENETRATIONS THROUGH RETAINING WALLS, PROVIDING SLEEVES WHERE SHOWN OR REQUIRED.

PILE/LAGGING TABLE

| | TOP OF PILE | TOP LAGGING (N) | BOTTOM LAGGING (N) | TOP LAGGING (S) | BOTTOM LAGGING (S) | MIN. PILE EMBEDMENT |
|---------------------------------------|-------------|-----------------|--------------------|-----------------|--------------------|---------------------|
| LOWER SOLIDER PILES, SPACING PER PLAN | | | | | | |
| A | 82.0 | N/A | N/A | 82.0 | 70.3 | 18ft |
| B | 82.0 | 82.0 | 70.3 | 82.0 | 70.3 | 18ft |
| C | 82.0 | 82.0 | 70.3 | 82.0 | 70.3 | 18ft |
| D | 82.0 | 82.0 | 70.3 | 82.0 | 70.3 | 18ft |
| E | 82.0 | 82.0 | 70.3 | 82.0 | 70.3 | 18ft |
| F | 82.0 | 82.0 | 70.3 | N/A | N/A | 18ft |
| UPPER SOLIDER PILES, SPACING PER PLAN | | | | | | |
| G | 86.0 | N/A | N/A | 86.0 | 83.0 | 13ft |
| H | 88.5 | 86.0 | 83.0 | 88.5 | 83.0 | 13ft |
| I | 91.75 | 88.5 | 83.0 | 91.75 | 83.0 | 14ft |
| J | 91.75 | 91.75 | 83.0 | 91.75 | 83.0 | 14ft |
| K | 95.3 | 91.75 | 83.0 | 95.3 | 83.0 | 19ft |
| L | 95.3 | 95.3 | 83.0 | 95.3 | 83.0 | 28ft |
| M | 95.3 | 95.3 | 83.0 | 95.3 | 83.0 | 28ft |
| N | 95.3 | 95.3 | 83.0 | 95.3 | 83.0 | 28ft |
| O | 95.3 | 95.3 | 83.0 | 95.3 | 83.0 | 28ft |
| P | 95.3 | 94.0 | 83.0 | 95.3 | 83.0 | 28ft |
| Q | 94.0 | 94.0 | 83.0 | 91.75 | 83.0 | 28ft |
| R | 91.75 | 91.75 | 83.0 | N/A | N/A | 28ft |

- ALL LAGGING TO BE PRESSURE TREATED.
- PILES SHALL BE COATED WITH CORROSION PROTECTION PAINT.
- USE CONCRETE $f_c = 2,500$ psi TO EMBED PILES

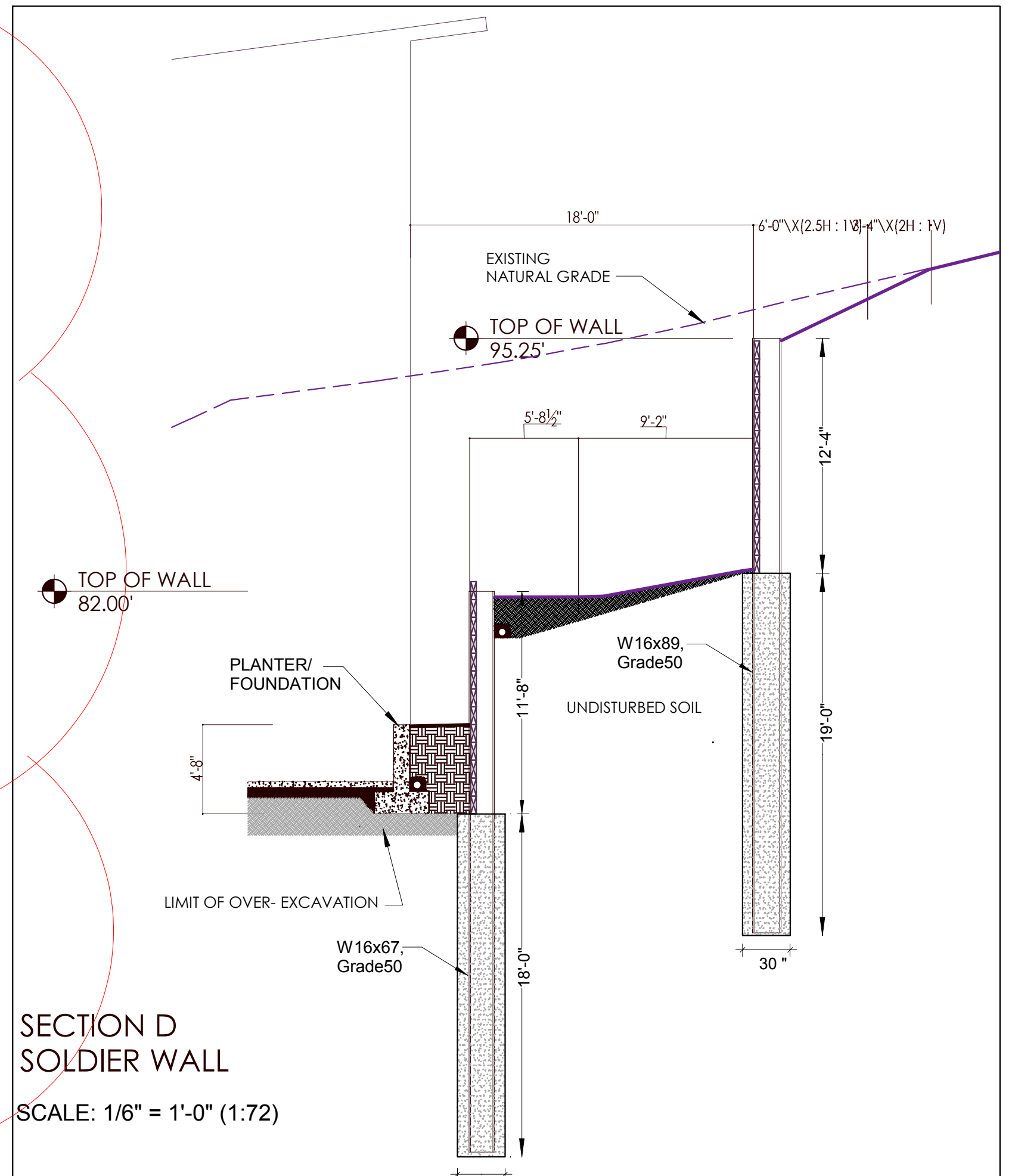

NOTE:
REFER TO GEOTECHNICAL REPORT ADDENDUM
EVALUATION OF SURCHARGE LOAD ON THE SOLDIER PILE WALL
PROPOSED SIGLE-FAMILY RESIDENCE
4634 E MERCER WAY, MERCER ISLAND, WA
FOR FURTHER INFORMATION.

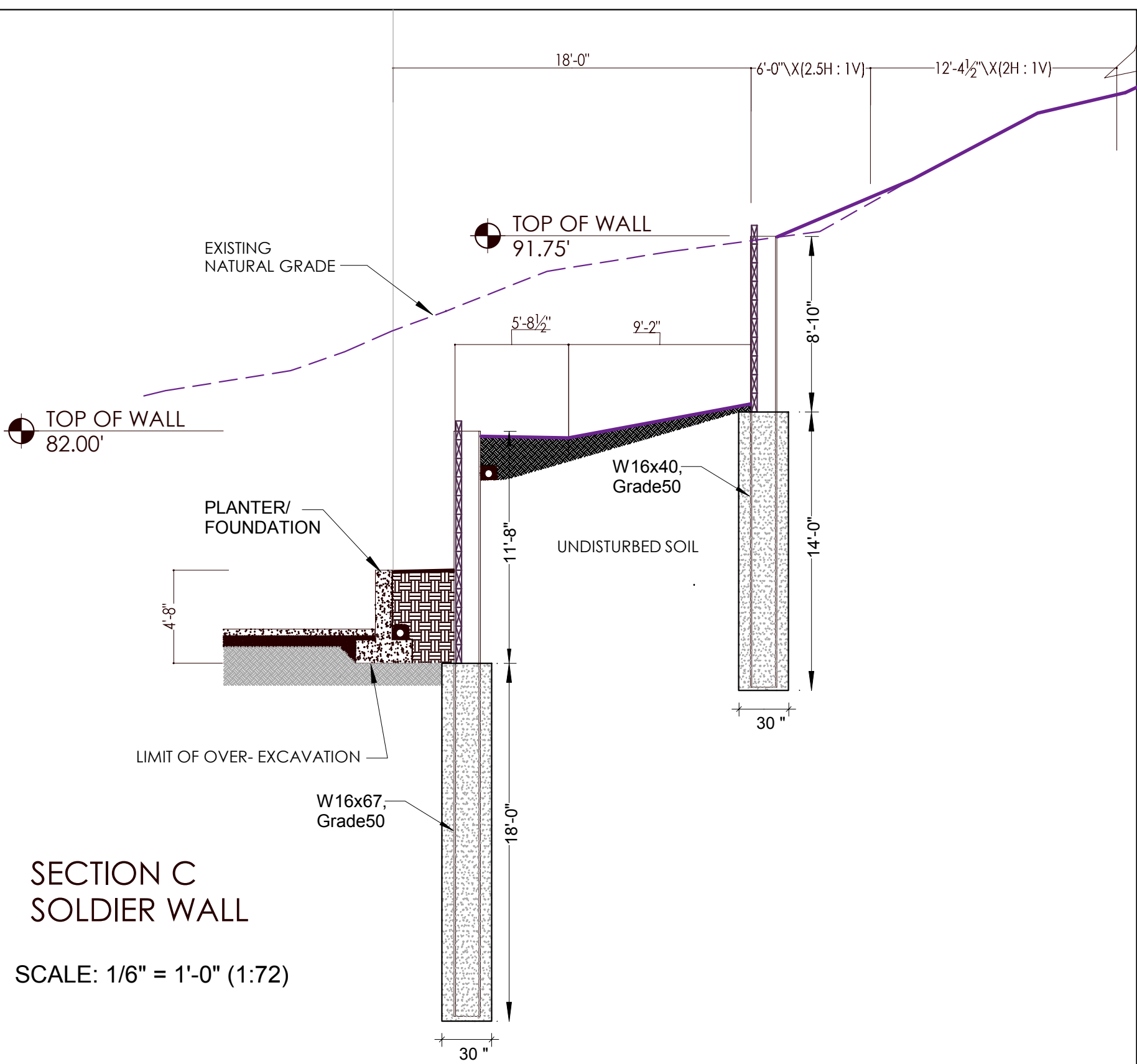
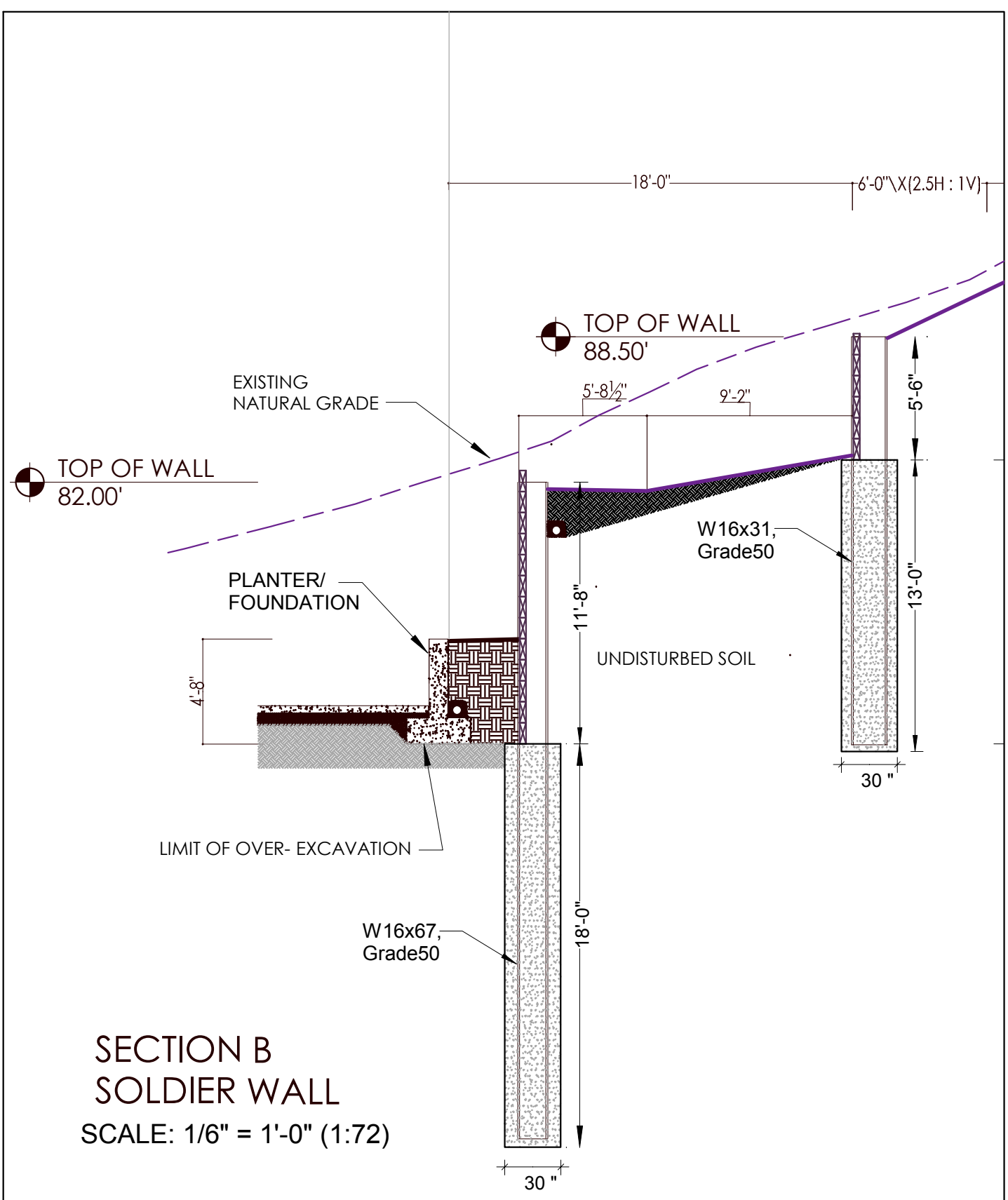
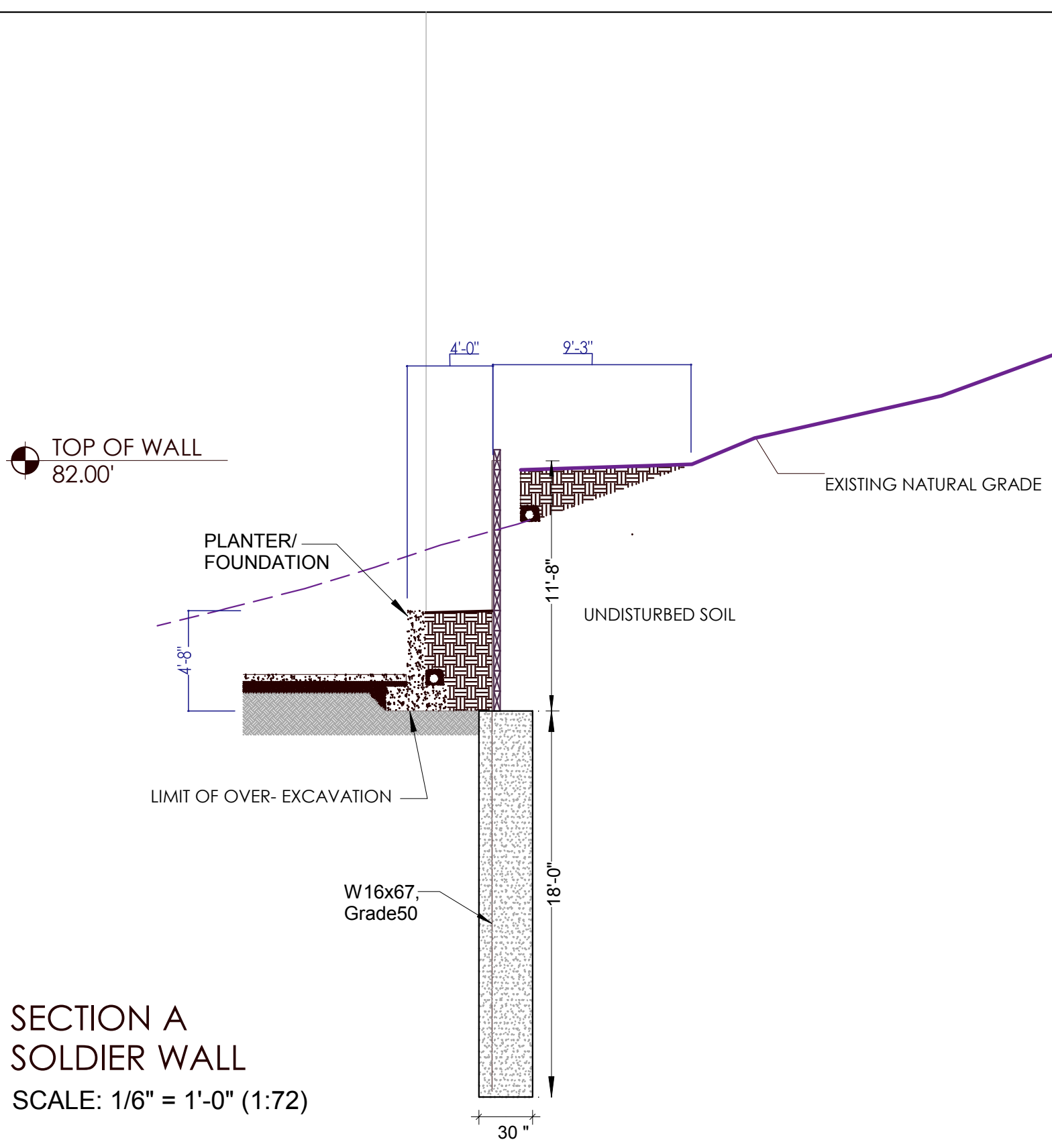

REVISION 08/12/16

tec instruct LLC
6830 NE Bothell Way - Suite C, PMB 181, Kenmore, WA 98028
Telephone (206) 553 9076 - Fax (206) 529 4408
ENGINEERING

| | | |
|--------------|----------------------------------|-----------------|
| BUILDER: | Barcelo Homes | SHEET |
| JOB SITE: | 4634 E Mercer Way, Mercer Island | S10 |
| PARCEL NO.: | WA 98040 | |
| DESCRIPTION: | Solider Pile Shoring | |
| DATE: | 03/11/15 | SCALE: as noted |
| ENGINEER: | Roland Heimisch, P. E. | |

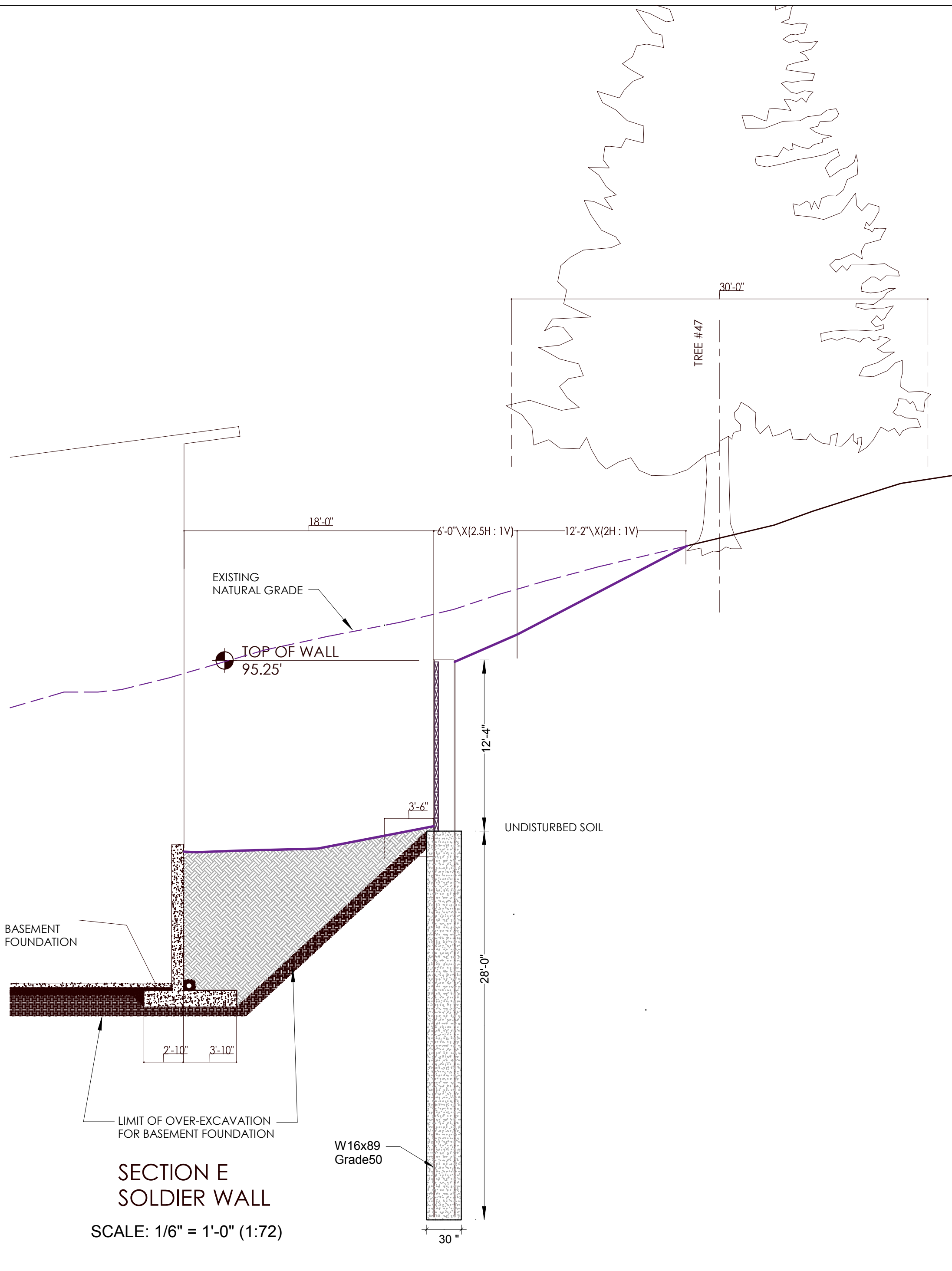

Shoring Construction Sequence

1. Grade and excavate to the top of the upper wall
2. Drill 2.5 ft dia. holes for upper wall to bottom of embedment and install steel piles
3. Dig soil in sections only deep enough to immediately install lagging
Install lagging following the excavation to the top level of the lower wall
4. Drill 2.5 ft dia. holes for lower wall to bottom of embedment and install steel piles
5. Dig soil in sections only deep enough to immediately install lagging
Install lagging following the excavation to the bottom level of the wall

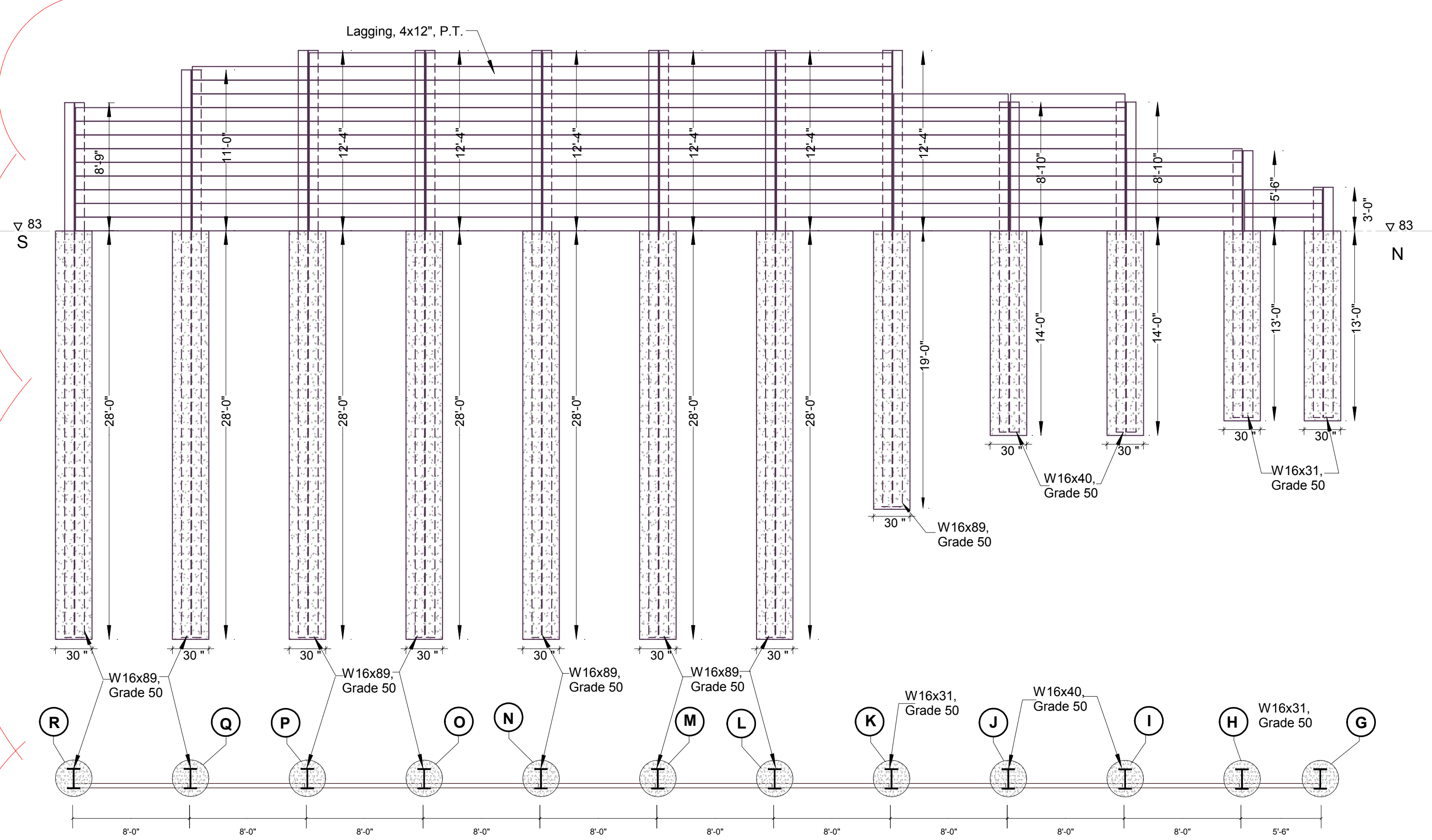

UPPER LINE OF SOLDIER PILE SHORING

SCALE: 1/6" = 1'-0" (1:72)

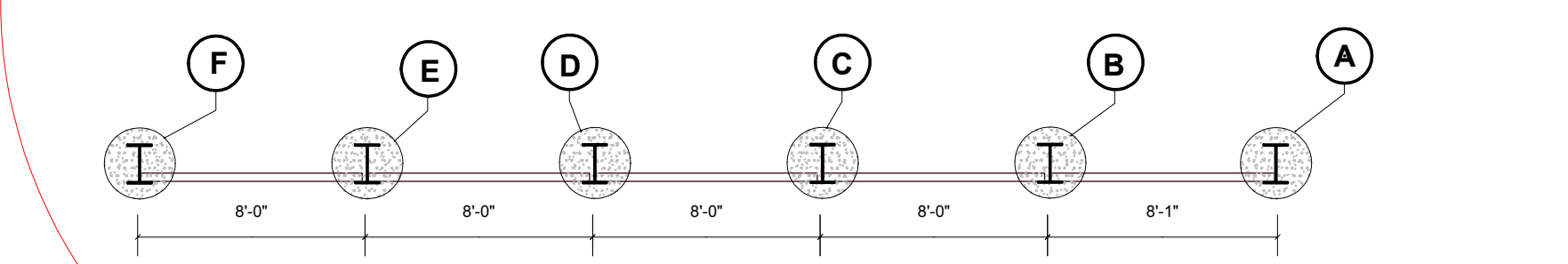
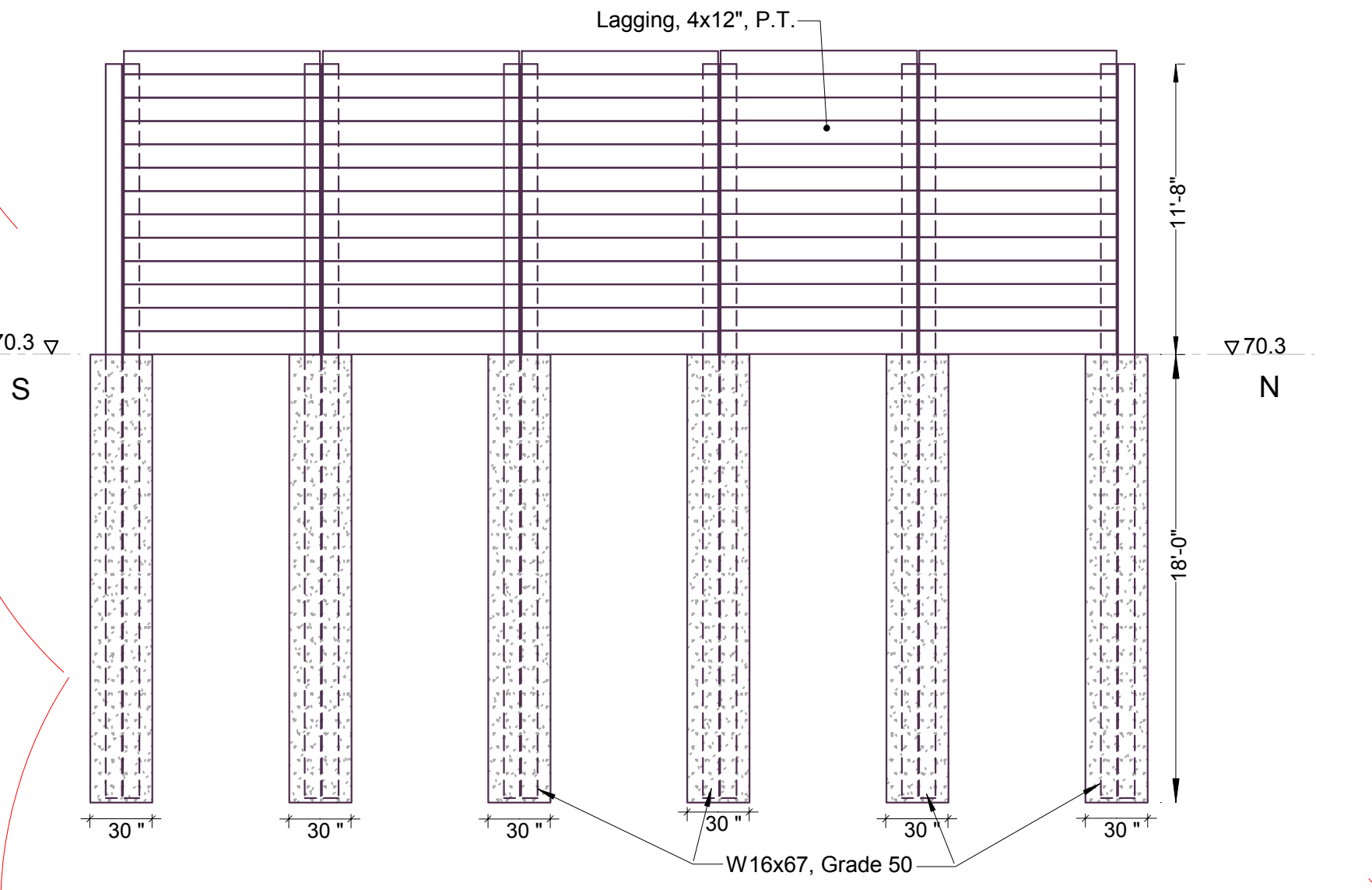

LOWER LINE OF SOLDIER PILE SHORING

SCALE: 1/6" = 1'-0" (1:72)

| KEY NO. | STRUCTURAL MEMBERS |
|-------------------|---|
| FOUNDATION | |
| 4.9 | Lower soldier Pile Wall, all Sections, W16x67, Grade 50 |
| 4.10 | Upper Soldier Pile Wall, Section B, W16x31, Grade 50 |
| 4.11 | Upper Soldier Pile Wall, Section C, W16x40, Grade 50 |
| 4.12 | Upper Soldier Pile Wall, Section D, W16x89, Grade 50 |
| 4.13 | Soldier Pile Wall, Section E, W16x89, Grade 50 |



REVISION 08/12/16

| | | | |
|--|----------------------------------|-----------------|-------|
|  tec instruct LLC 6830 NE Bothell Way - Suite C, PMB 181, Kenmore, WA 98028 Telephone (206) 553 9076 - Fax (206) 529 4408 ENGINEERING | | S11 | |
| BUILDER: | Barcelo Homes | | SHEET |
| JOB SITE: | 4634 E Mercer Way, Mercer Island | | |
| PARCEL NO.: | WA 98040 | | |
| DESCRIPTION: | Soldier Pile Shoring | | |
| DATE: | 03/11/15 | SCALE: as noted | |
| ENGINEER: | Roland Heimisch, P. E. | | |

February 4, 2016
File No. 14-032.200

Barcelo Homes, LLC
32505 138th Place SE
Auburn, WA 98092
Attn: Bogdan Maksimchuk

**Subject: Geotechnical Report Addendum
Temporary Excavation and Soldier Pile Wall Recommendations
Proposed Single-Family Residence
4634 E Mercer Way, Mercer Island, WA**

Dear Mr. Maksimchuk,

This letter is prepared to provide our additional geotechnical recommendations for the temporary excavations and soldier pile wall design for the above-referenced project. We understand that the temporary excavations up to 20 feet will be required to construct the proposed basement and foundation walls along the west building line and for the parking areas. As such, temporary shoring will be needed to support excavations and reduce excavation quantity. Additionally, we further understand that concrete and soldier pile walls will be needed retain the permanent cuts. The following sections present our additional recommendations for the temporary excavation support and soldier pile wall design for the above project.

ULTRABLOCK SHORING WALL

Ultrablock wall (2½x2½x5½ feet in dimension) may be considered one temporary shoring method. If used, the Ultrablock wall should have a maximum height of 7½ feet (three blocks high) and installed with a 1H:8V batter, or flatter, combined with a 1H:1V slope (maximum 5 feet high) above the wall. We recommend that the following be incorporated into the project plans:

- The maximum wall height of staggered blocks is 7½ feet (i.e., 3 blocks in height);

- The vertical wall face is no steeper than 1H (Horizontal):8V (Vertical);
- The 1H:V slope above the ultrablock wall should have a maximum height of 5 feet;
- The subgrade at the base of the ultrablock blocks shall consist of dense native soil or leveling crushed rock placed on dense soil;
- The grade in front of the block wall should have a minimum of 10 feet level ground;
- No excavation shall be made until blocks are available on site;
- The width of unsupported cut face for block placement shall be limited to no more than about 10 feet at any given time;
- Blocks shall be placed immediately after the cut is made, otherwise the cut face shall be buttressed with on-site soils until the blocks can be placed;
- Any voids behind blocks shall be backfilled with gravel immediately after the block wall are installed; and

SOLDIER PILE SHORING WALL

Soldier pile walls may be used as temporary shoring walls to support the excavations or as permanent site retaining walls to retain the cuts. We recommend that the following design parameters be used for the design of soldier pile shoring walls:

- Active Earth Pressure: 35 pcf for level backslope
48 pcf for maximum 2H:1V backslope
- Passive Resistance: 300 pcf (allowable)
- Lagging: 250 psf (uniform distribution)
- Surcharges: A lateral load coefficient of 0.3 should be used to compute the lateral pressure on the shoring wall resulting from surcharge loads located within a horizontal distance of one-half wall height

- Seismic Pressure: If the soldier pile walls will be designed as permanent walls, a uniform lateral earth pressure of $8H$ psf (where H is the wall height) should be added to the static pressure for evaluating the seismic condition
- Wall Deflection: Soldier pile walls should be designed with less than one inch of top of wall deflection

The active earth pressure should be applied over the full width of pile spacing above the base of excavation, and over one pile diameter (i.e. diameter of drilled hole) below the base of excavation. The passive resistance should be applied over two pile diameter or one pile spacing, whichever is less. The minimum soldier pile embedment should be determined by the shoring wall designer, and should extend at least 10 feet below the bottom of the proposed excavation.

The recommended passive earth pressure assumes level ground surface at the bottom of the excavation, and the level bench extends at least 15 feet in front of the wall. If the ground surface in front of the wall needs to be sloped to accommodate the difference in finish floor elevation, the passive resistance in the sloped portion of the ground should be ignored or reduced for design calculations.

We recommend that any voids behind the timber lagging be backfilled with 5/8" clean crushed rock or Controlled Density Fill (CDF), depending on the soil conditions.

CLOSURE

We trust that the information presented herein meets your need at this time. Please call if you have any questions.

Sincerely,



Michael H. Xue, P.E.
Senior Geotechnical Engineer

July 11, 2014
Revised February 2, 2015
File No. 14-128

Barcelo Homes, LLC
32505 138th Place SE
Auburn, WA 98092
Attn: Bogdan Maksimchuk

**Subject: Geotechnical Engineering Study (Revised)
Proposed Development
4634 E Mercer Way, Mercer Island, WA**

Dear Mr. Maksimchuk,

As requested, PanGEO, Inc. has completed a geotechnical engineering study for the proposed development at the above-referenced site. This study was performed in general accordance with our mutually agreed scope of work outlined in our proposal dated May 6, 2014, and was subsequently approved by you on May 7, 2014. Our service scope included reviewing readily-available geologic and geotechnical data in the project vicinity, reviewing preliminary design plans, drilling three test borings, conducting a site reconnaissance, and developing the conclusions and recommendations presented in this report.

SITE AND PROJECT DESCRIPTION

The subject site is an approximately 21,350 square foot vacant lot located immediately south of 4624 E Mercer Way, and setback approximately 120 feet east of East Mercer Way, in the City of Mercer Island, Washington (see Vicinity Map, Figure 1). The subject lot is bordered by existing single-family residences on all four sides. The site grade generally slopes down from west to east with an average gradient of approximately 25 percent. The site is currently covered with ivy, bushes, and some mature trees.

We understand that you plan to construct a single-family residence in the eastern portion of the lot (see Figure 2). Based on review of preliminary design information provided to us, we understand that the proposed residence will be a wood frame, three-story structure with an attached garage (see Plate 1 on page 2). We anticipate that site grading for the proposed

construction will likely include cuts up to 10 to 12 feet deep along the west building wall and retaining walls, and fill on the order of 5 to 6 feet or less for retaining wall construction.

According to the City of Mercer Island, the subject property contains several mapped geologic hazards, including steep slopes, potential landslide, seismic, and erosion hazards. As such, a geotechnical report will be required as part of the building permit application.

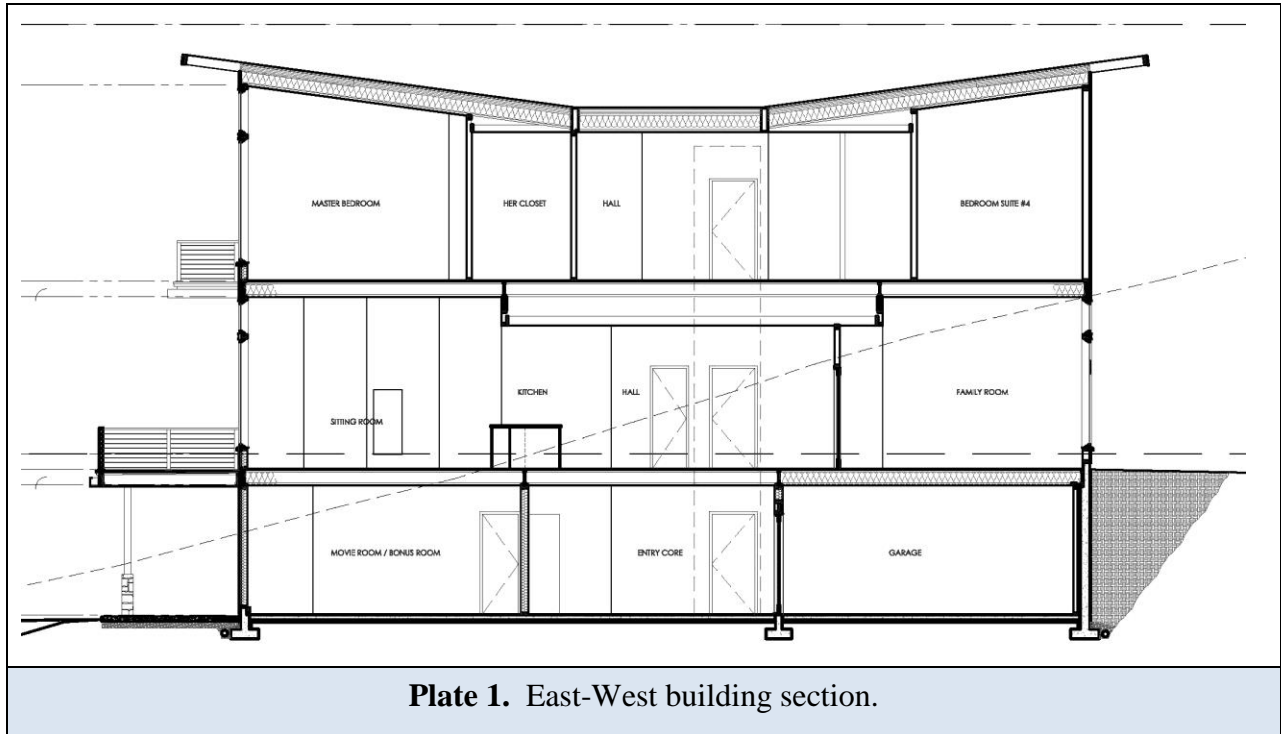

The conclusions and recommendations in this report are based on our understanding of the proposed development, which is in turn based on the project information provided. If the above project description is incorrect, or the project information changes, we should be consulted to review the recommendations contained in this study and make modifications, if needed.

SUBSURFACE EXPLORATIONS

Three borings (BH-1 through BH-3) were drilled at the site on May 16 and June 2, 2014, using a hand-operated portable drill rig owned and operated by CN Drilling of Seattle, Washington. The approximate boring locations were taped in the field from on-site features and are shown on Figure 2. The borings were drilled to depths of about 16½ to 21½ feet.

The drill rig was equipped with 4-inch outside diameter hollow stem augers. Soil samples were obtained from the borings at 2½-foot depth intervals in general accordance with Standard Penetration Test (SPT) sampling methods (ASTM test method D-1586) in which the samples are obtained using a 2-inch outside diameter split-spoon sampler. The sampler was driven into the soil a distance of 18 inches using a 140-pound weight freely falling a distance of 30 inches. The number of blows required for each 6-inch increment of sampler penetration was recorded. The number of blows required to achieve the last 12 inches of sample penetration is defined as the SPT N-value. The N-value provides an empirical measure of the relative density of cohesionless soil, or the relative consistency of fine-grained soils.

A geologist and an engineer from PanGEO were present to observe the drilling, assist in sampling, and to describe and document the soil samples obtained from the borings. The soil samples were described and field classified in general accordance with the symbols and terms outlined in Figure A-1, and the summary boring logs are included as Figures A-2 through A-4.

SITE GEOLOGY AND SUBSURFACE CONDITIONS

SITE GEOLOGY

The Geologic Map of Mercer Island (Troost and Wisher, 2006) mapped the surficial geologic unit at the subject site as Pre-Olympia Nonglacial Deposits (Qpon). Lawton Clay (Qvlc) and Advance Outwash (Qva) deposits were mapped west of East Mercer Way, approximately 120 feet west and upslope of the site. Pre-Olympia Nonglacial deposits are described by Troost, et al. as laminated to massive, silt and clay with sand interbeds to clean to silty sand and gravel with silt and peat interbeds that had been overridden by Olympia Interglaciation. Lawton Clay (Qvlc) typically consists of very stiff to hard, laminated to massive, silt, clayey silt, and silty clay that deposited in Puget Lowland proglacial lakes. Advance Outwash (Qva) typically consists of dense, well-sorted sand and gravel deposited by streams issuing from advancing ice sheet.

SUBSURFACE AND GROUNDWATER CONDITIONS

The soils encountered in the borings are interpreted as colluvium overlying Pre-Olympia deposits. The following is a description of the soils encountered in the test borings advanced at the site. Please refer to the boring summary logs (Figures A-2 through A-4) for a detailed description of the conditions encountered at each boring location.

UNIT 1: Colluvium – Very loose to medium dense, slightly silty sand to sand with silt with trace to some gravel were encountered from the surface to about 4½ to 11 feet in the borings. Based on the blow-counts and structure of the soil samples, we interpret this unit to be colluvium or slope wash deposits.

UNIT 2: Pre-Olympia Deposits – Below Colluvium/Slope Wash, both borings encountered medium dense to very dense silty sand to sand with silt that extended to the maximum depths drilled of about 16½ to 21½ feet below the surface. This unit appears to be consistent with the mapped Pre-Olympia Nonglacial deposits.

Groundwater was not encountered during drilling. However, very moist to wet soil sample was observed at about 20 feet in boring BH-1, suggesting approaching the groundwater table. It should be noted that groundwater elevations and seepage rates are likely to vary depending on the season, local subsurface conditions, and other factors. Groundwater levels and seepage rates are normally highest during the winter and early spring.

GEOLOGY HAZARDS ASSESSMENT

Landslide Hazards and Steep Slopes

The subject site is mapped within a potential landslide hazard area according to the City of Mercer Island's Geologic Hazards Map. A site reconnaissance of the subject property was conducted on May 16, 2014. During our site reconnaissance, we did not observe obvious evidence of slope instability or ground movement at the site. Based on our field observations, the general topography at the site and vicinity, and the results of our subsurface explorations, in our opinion, the subject site appears to be globally stable in its current configuration. Furthermore, it is our opinion that the proposed development as currently planned is feasible from a geotechnical engineering standpoint and in our opinion will not adversely affect the overall stability of the site or adjacent properties, provided the recommendations outlined herein are followed and the proposed development is properly design and constructed.

Seismic Hazards

Based on our review of the City of Mercer Island's Geologic Hazards Maps, the subject site is mapped within a seismic hazard area. The City of Mercer Island Code defines seismic hazard areas as those areas subject to risk of damage as a result of earthquake-induced ground

shaking, slope failure, and soil liquefaction or surface faulting. Based on the soil conditions encountered and lack of shallow groundwater table, in our opinion, the potential for soil liquefaction during an IBC-code level earthquake is considered low. It is also our opinion that the potential for seismic-induced landsliding is low at the site due to the relatively mild slope gradient. Therefore, special design considerations associated with soil liquefaction and seismic-induced landsliding are not necessary for this project.

Erosion Hazards

The subject site is mapped within a potential erosion hazard area according to the City of Mercer Island's Geologic Hazards Map. Based on soil conditions encountered in the borings, the near-surface site soils are likely to exhibit moderate erosion potential. In our opinion, the erosion hazards at the site can be effectively mitigated with the best management practice during construction and with properly designed and implemented landscaping for permanent erosion control. During construction, the temporary erosion hazard can be effectively managed with an appropriate erosion and sediment control plan, including but not limited to installing silt fence at the construction perimeter, limiting removal of vegetation to the construction area, placing rocks or hay bales at the disturbed/traffic areas and on the downhill side of the project, covering stockpile soil or cut slopes with plastic sheets, constructing a temporary drainage pond to control surface runoff and sediment trap, placing quarry spalls at the construction entrance, etc. Permanent erosion control measures should include establishing vegetation, landscape plants, and hardscape established at the end of project, and reducing surface runoff to the minimum extent possible.

GEOTECHNICAL DESIGN RECOMMENDATIONS

SEISMIC DESIGN PARAMETERS

The Table 1 on page 6 provides seismic design parameters for the site that are in conformance with the 2012 edition of the International Building Code (IBC), which specifies a design earthquake having a 2% probability of occurrence in 50 years (return interval of 2,475 years), and the 2008 USGS seismic hazard maps:

Table 1 – Seismic Design Parameters

| Site Class | Spectral Acceleration at 0.2 sec. (g) | Spectral Acceleration at 1.0 sec. (g) | Site Coefficients | | Design Spectral Response Parameters | |
|------------|---------------------------------------|---------------------------------------|-------------------|----------------|-------------------------------------|-----------------|
| | S _s | S ₁ | F _a | F _v | S _{DS} | S _{D1} |
| D | 1.419 | 0.545 | 1.00 | 1.50 | 0.946 | 0.545 |

BUILDING FOUNDATIONS

Based on the subsurface conditions encountered and the building design foundation elevations, it is our opinion that conventional shallow footings may be used to support the proposed building. Conventional footings should bear on the recompacted medium dense to dense undisturbed Pre-Olympia Deposits, or structural fill placed on competent native soils. Fill and colluvium should be removed from the footing subgrade and backfilled with structural fill. We anticipate that over-excavations will be required in the eastern portion of the building footprint to reach native competent soil. Exterior foundation elements should be placed at a minimum depth of 18 inches below final exterior grade. Interior spread foundations should be placed at a minimum depth of 12 inches below the top of slab.

We recommend that an allowable soil bearing pressure of 2,500 pounds per square feet (psf) be used for sizing the footings. The recommended allowable bearing pressure is for dead plus live loads. For allowable stress design, the recommended bearing pressure may be increased by one-third for transient loading, such as wind or seismic forces. Continuous and individual spread footings should have minimum widths of 18 and 24 inches, respectively.

Foundation Performance – Footings designed and constructed in accordance with the above recommendations should experience total settlement of less than one inch and differential settlement of less than ½ inch. Most of the anticipated settlement should occur during construction as dead loads are applied.

Lateral Resistance – Lateral loads on the structures may be resisted by passive earth pressure developed against the embedded faces of the foundation system and by frictional resistance between the bottom of the foundation and the supporting subgrade soils. For footings bearing on

the dense native soil or compacted sand/structural fill, a frictional coefficient of 0.4 may be used to evaluate sliding resistance developed between the concrete and the compacted subgrade soil. Passive soil resistance may be calculated using an equivalent fluid weight of 300 pcf, assuming properly compacted structural fill will be placed against the footings. The above values include a factor of safety of 1.5. Unless covered by pavements or slabs, the passive resistance in the upper 12 inches of soil should be neglected.

Perimeter Footing Drain – Footing drains should be installed around the perimeter of the building, at or just below the invert of the footings. Under no circumstances should roof downspout drain lines be connected to the footing drain systems. Roof downspouts must be separately tightlined to appropriate discharge locations. Cleanouts should be installed at strategic locations to allow for periodic maintenance of the footing drain and downspout tightline systems.

Footing Excavation and Subgrade Preparation – All footing subgrades should be carefully prepared. Any fill, colluvium, loose/soft, or organic-rich subgrade soil should be removed from the footing excavations. The footing subgrade may need to be recompacted to a dense, unyielding condition using a jumping jack or other heavy compaction equipment, prior to form setting and rebar placement. The adequacy of footing subgrade should be verified by a representative of PanGEO, prior to placing forms or rebar. We anticipate that over-excavations up to 3 to 4 feet may be required in the eastern portion of the building footprint to reach native competent soil. The over-excavation should be backfilled with compacted structural fill or lean-mix concrete. The over-excavation width should extend at least one-half the over-excavation depth beyond the edge of footing.

FLOORS SLABS

The floor slabs for the proposed building may be constructed using conventional concrete slab-on-grade floors construction. The floor slabs may be supported on recompacted native sandy soil or structural fill placed on properly compacted on-site sandy soil. Organic-rich soil or loose soil that cannot be compacted to a dense condition at the slab subgrade level should be over-excavated and replaced with compacted structural fill.

Interior concrete slab-on-grade floors should be underlain by at least of 4 inches capillary break. The capillary break material should be clean crushed rocks that have no more than 10 percent

passing the No. 4 sieve and less than 5 percent by weight of the material passing the U.S. Standard No. 100 sieve. The capillary break should be placed on the subgrade that has been compacted to a dense and unyielding condition. A 10-mil polyethylene vapor barrier should also be placed directly below the slab. We also recommend that construction joints be incorporated into the floor slab to control cracking.

RETAINING AND BASEMENT WALL DESIGN PARAMETERS

Retaining and basement walls should be properly designed to resist the lateral earth pressures exerted by the soils behind the wall. Proper drainage provisions should also be provided behind the walls to intercept and remove groundwater that may be present behind the wall. Our geotechnical recommendations for the design and construction of the retaining/basement walls are presented below.

Lateral Earth Pressures

Concrete cantilever walls should be designed for an equivalent fluid pressure of 35 pcf for level backfills behind the walls assuming the walls are free to rotate. If walls are to be restrained at the top from free movement, such as below-grade building walls, equivalent fluid pressures of 45 pcf should be used for level backfills behind the walls. Walls with a maximum 2H:1V backslope should be designed for an active and at rest earth pressure of 45 and 55 pcf, respectively.

Permanent walls should be designed for an additional uniform lateral pressure of 7H psf for seismic loading, where H corresponds to the buried depth of the wall. The recommended lateral pressures assume that the backfill behind the wall consists of a free draining and properly compacted fill with adequate drainage provisions.

Surcharge

Surcharge loads, where present, should also be included in the design of retaining walls. We recommend that a lateral load coefficient of 0.3 be used to compute the lateral pressure on the wall face resulting from surcharge loads located within a horizontal distance of one-half wall height.

Lateral Resistance

Lateral forces from seismic loading and unbalanced lateral earth pressures may be resisted by a combination of passive earth pressures acting against the embedded portions of the foundations and by friction acting on the base of the foundations. Passive resistance values may be determined using an equivalent fluid weight of 300 pcf. This value includes a factor of safety of 1.5, assuming the footing is poured against dense native sand, re-compacted on-site sandy soil or properly compacted structural fill adjacent to the sides of footing. A friction coefficient of 0.4 may be used to determine the frictional resistance at the base of the footings. The coefficient includes a factor safety of 1.5.

Wall Drainage

Provisions for wall drainage should consist of a 4-inch diameter perforated drainpipe behind and at the base of the wall footings, embedded in 12 to 18 inches of clean crushed rock and pea gravel wrapped with a layer of filter fabric. A minimum 18-inch wide zone of free draining granular soils (i.e. pea gravel or washed rock) is recommended to be placed adjacent to the wall for the full height of the wall. Alternatively, a composite drainage material, such as Miradrain 6000, may be used in lieu of the clean crushed rock or pea gravel. The drainpipe at the base of the wall should be graded to direct water to a suitable outlet.

The exterior of all basement walls should be protected with a damp proofing compound. We also recommend the designers consider utilizing a waterproofing material, such as prefabricated clay mats, on the exterior of all below grade walls to reduce the potential for moisture intrusion into the below-grade portion of the building.

Wall Backfill

In our opinion, the relatively clean on-site sandy soil may be re-used as wall backfill. Imported wall backfill, if needed, should consist of granular material, such as WSDOT Gravel Borrow or approved equivalent. In areas where the space is limited between the wall and the face of excavation, pea gravel or clean crushed rock may be used as backfill without compaction.

Wall backfill should be moisture conditioned to within about 3 percent of optimum moisture content, placed in loose, horizontal lifts less than 8 inches in thickness, and systematically compacted to a dense and relatively unyielding condition and to at least 95 percent of the

maximum dry density, as determined using test method ASTM D 1557. Within 5 feet of the wall, the backfill should be compacted with hand-operated equipment to at least 90 percent of the maximum dry density.

CONSTRUCTION CONSIDERATIONS

SITE PREPARATION

Site preparation for the proposed project mainly includes site clearing and excavations to the design subgrade. All debris resulted from site clearing should be hauled away from the site. The stripped surface materials should be properly disposed off-site or be “wasted” on site in non-structural landscaping areas.

Following site clearing and excavations, the adequacy of the subgrade where structural fill, foundations, slabs, or pavements are to be placed should be verified by a representative of PanGEO. The subgrade soil in the improvement areas, if recompacted and still yielding, may need to be over-excavated and replaced with compacted structural fill or lean-mix concrete. The need for overexcavation should be determined by PanGEO.

TEMPORARY EXCAVATIONS

As currently planned, the proposed development may require excavations up to about 10 to 12 feet deep. The deepest excavation will occur at the west side of the building. We anticipate the excavations to mainly encounter loose to very dense sand with variable amounts of silt and gravel (colluvium and Pre-Olympia Deposits). All temporary excavations should be performed in accordance with Part N of WAC (Washington Administrative Code) 296-155. The contractor is responsible for maintaining safe excavation slopes and/or shoring.

All temporary excavations with a total overall depth greater than 4 feet should be sloped or shored. Based on the soil conditions at the site, for planning purposes, it is our opinion that temporary excavations for the proposed construction may be sloped 1H:1V or flatter. Based on our conceptual building layout, in our opinion, unsupported open cut excavation is likely feasible for the proposed development, and temporary shoring to support excavations is likely not needed.

The temporary excavations and cut slopes should be re-evaluated in the field during construction based on actual observed soil conditions, and may need to be modified in the wet seasons. The

cut slopes should be covered with plastic sheets in the raining season. We also recommend that heavy construction equipment, building materials, excavated soil, and vehicular traffic should not be allowed within a distance equal to 1/3 the slope height from the top of any excavation.

MATERIAL REUSE

In the context of this report, structural fill is defined as compacted fill placed under footings, concrete stairs and landings, and slabs, or other load-bearing areas. In our opinion, the on-site sandy soil may be used as structural fill, provided they can be compacted to a dense condition. Imported structural fill, if needed, should consist of well-graded, granular material, such as WSDOT Gravel Borrow (WSDOT 9-03.14(1)) or approved equivalent. Well-graded recycled concrete may also be considered as a source of structural fill. Use of recycled concrete as structural fill should be approved by the geotechnical engineer. The on-site fill may be used as general fill in the non-structural and landscaping areas. If use of the on-site soil is planned, the excavated soil should be stockpiled and protected with plastic sheeting to prevent softening from rainfall in the wet season.

STRUCTURAL FILL PLACEMENT AND COMPACTION

Structural fill should be moisture conditioned to within about 3 percent of optimum moisture content, placed in loose, horizontal lifts less than 8 inches in thickness, and systematically compacted to a dense and relatively unyielding condition and to at least 95 percent of the maximum dry density, as determined using test method ASTM D 1557.

Depending on the type of compaction equipment used and depending on the type of fill material, it may be necessary to decrease the thickness of each lift in order to achieve adequate compaction. PanGEO can provide additional recommendations regarding structural fill and compaction during construction.

WET WEATHER EARTHWORK

In our opinion, the proposed site construction may be accomplished during wet weather (such as in winter) without adversely affecting the site stability. However, earthwork construction performed during the drier summer months likely will be more economical. Winter construction will require the implementation of best management erosion and sedimentation control practices to reduce the risk of off-site sediment transport. Most of the site soils within the anticipated

depth of excavation contain a high percentage of fines and are moisture sensitive. Any footing subgrade soils that become softened either by disturbance or rainfall should be removed and replaced with structural fill, Controlled Density Fill (CDF), or lean-mix concrete. General recommendations relative to earthwork performed in wet conditions are presented below:

- Site stripping, excavation and subgrade preparation should be followed promptly by the placement and compaction of clean structural fill or CDF;
- The size and type of construction equipment used may have to be limited to prevent soil disturbance;
- The ground surface within the construction area should be graded to promote run-off of surface water and to prevent the ponding of water;
- Geotextile silt fences should be strategically located to control erosion and the movement of soil;
- Structural fill should consist of less than 5% fines; and
- Excavation slopes should be covered with plastic sheets.

SURFACE DRAINAGE CONSIDERATIONS

Surface runoff can be controlled during construction by careful grading practices. Typically, this includes the construction of shallow, upgrade perimeter ditches or low earthen berms in conjunction with silt fences to collect runoff and prevent water from entering excavations or to prevent runoff from the construction area from leaving the immediate work site.

Permanent control of surface water should be incorporated in the final grading design. Adequate surface gradients and drainage systems should be incorporated into the design such that surface runoff is directed away from slopes and structures. Water from roof drains and other impervious areas should be properly collected and discharged into a storm drain system, and should not be discharged on to the slope areas.

ADDITIONAL SERVICES

To confirm that our recommendations are properly incorporated into the design and construction of the proposed residence, PanGEO should be retained to conduct a review of the final project

plans and specifications, and to monitor the construction of geotechnical elements. The City of Mercer Island, as part of the permitting process, will also require geotechnical construction inspection services. PanGEO can provide you a cost estimate for construction monitoring services at a later date.

We anticipate that the following additional services will be required:

- Review final project plans and specifications
- Verify implementation of erosion control measures;
- Verify adequacy of footing subgrade;
- Monitor pin pile driving and testing;
- Monitor temporary excavation;
- Verify the adequacy of subsurface drainage installation;
- Confirm the adequacy of the compaction of structural backfill; and
- Other consultation as may be required during construction

Modifications to our recommendations presented in this report may be necessary, based on the actual conditions encountered during construction.

CLOSURE

We have prepared this report for Barcelo Homes, LLC and the project design team. Recommendations contained in this report are based on a site reconnaissance, a subsurface exploration program, review of pertinent subsurface information, and our understanding of the project. The study was performed using a mutually agreed-upon scope of work.

Variations in soil conditions may exist between the locations of the explorations and the actual conditions underlying the site. The nature and extent of soil variations may not be evident until construction occurs. If any soil conditions are encountered at the site that are different from those described in this report, we should be notified immediately to review the applicability of our recommendations. Additionally, we should also be notified to review the applicability of our recommendations if there are any changes in the project scope.

The scope of our work does not include services related to construction safety precautions. Our recommendations are not intended to direct the contractors' methods, techniques, sequences or procedures, except as specifically described in our report for consideration in design. Additionally, the scope of our work specifically excludes the assessment of environmental characteristics, particularly those involving hazardous substances. We are not mold consultants nor are our recommendations to be interpreted as being preventative of mold development. A mold specialist should be consulted for all mold-related issues.

This report has been prepared for planning and design purposes for specific application to the proposed project in accordance with the generally accepted standards of local practice at the time this report was written. No warranty, express or implied, is made.

This report may be used only by the client and for the purposes stated, within a reasonable time from its issuance. Land use, site conditions (both off and on-site), or other factors including advances in our understanding of applied science, may change over time and could materially affect our findings. Therefore, this report should not be relied upon after 24 months from its issuance. PanGEO should be notified if the project is delayed by more than 24 months from the date of this report so that we may review the applicability of our conclusions considering the time lapse.

It is the client's responsibility to see that all parties to this project, including the designer, contractor, subcontractors, etc., are made aware of this report in its entirety. The use of information contained in this report for bidding purposes should be done at the contractor's option and risk. Any party other than the client who wishes to use this report shall notify PanGEO of such intended use and for permission to copy this report. Based on the intended use of the report, PanGEO may require that additional work be performed and that an updated report be reissued. Noncompliance with any of these requirements will release PanGEO from any liability resulting from the use this report.

We appreciate the opportunity to be of service.

Sincerely,



Michael H. Xue, P.E.
Senior Geotechnical Engineer

A handwritten signature in blue ink, appearing to read "Siew L. Tan".

Siew L. Tan, P.E.
Principal Geotechnical Engineer

Enclosures:

- Figure 1 Vicinity Map
- Figure 2 Site and Exploration Plan

Appendix A Summary Boring Logs

- Figure A-1 Terms and Symbols for Boring and Test Pit Logs
- Figure A-2 Log of Test Boring BH-1
- Figure A-3 Log of Test Boring BH-2
- Figure A-4 Log of Test Boring BH-3

REFERENCES

International Code Council, 2012, *International Building Code (IBC)*.

Troost, K.G., and Wisler, A. P, 2006. *Geologic Map of Mercer Island, Washington, scale 1:24,000*.

WSDOT, 2014, *Standard Specifications for Road, Bridge and Municipal Construction, M 41-10*.

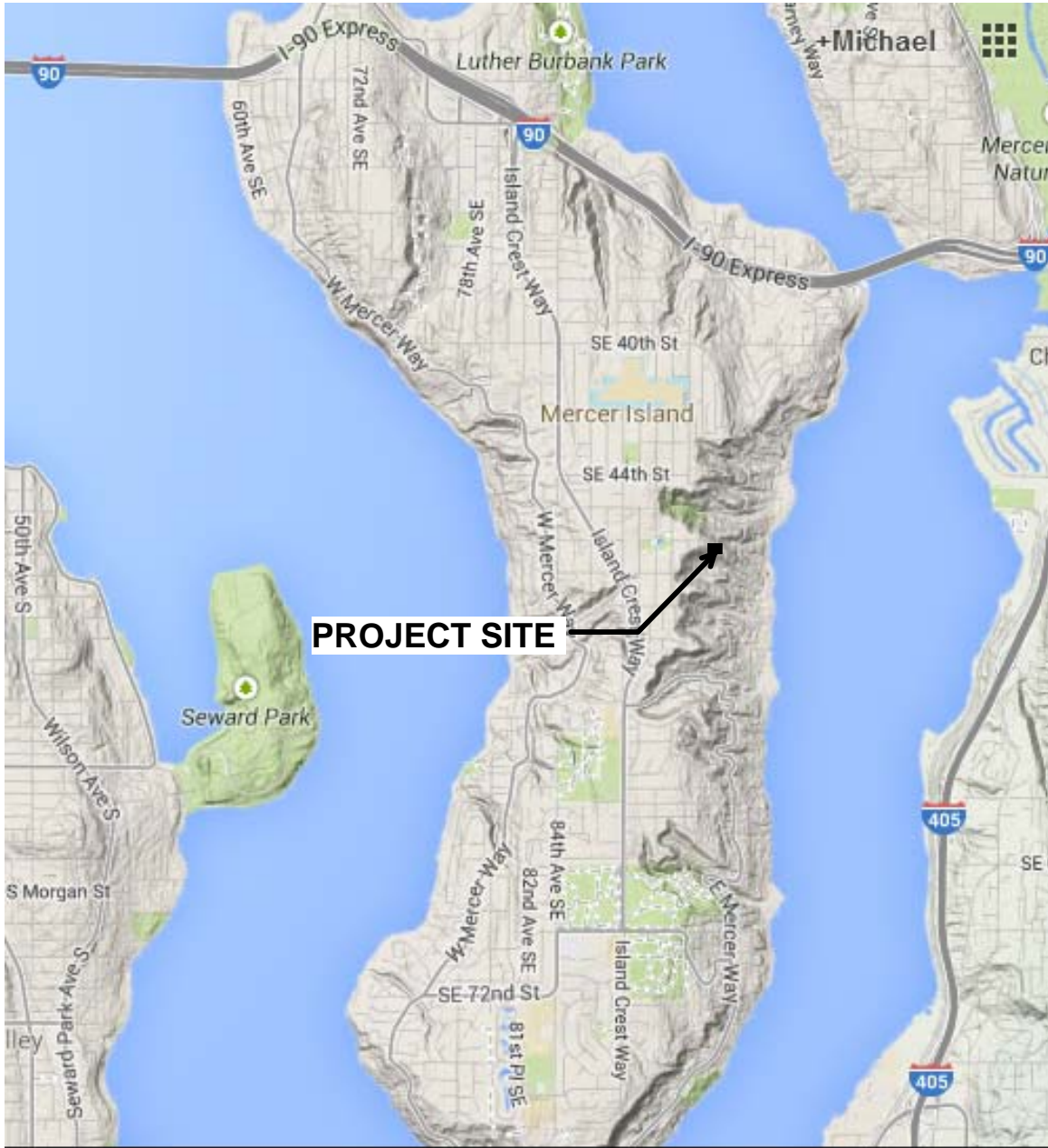

PROJECT SITE



Not to Scale

Base Map: Google Maps



**Proposed Development
4634 E Mercer Way
Mercer Island, WA**

VICINITY MAP

Project No. **14-128**

Figure No. **1**

Approx. Scale
1"=20"

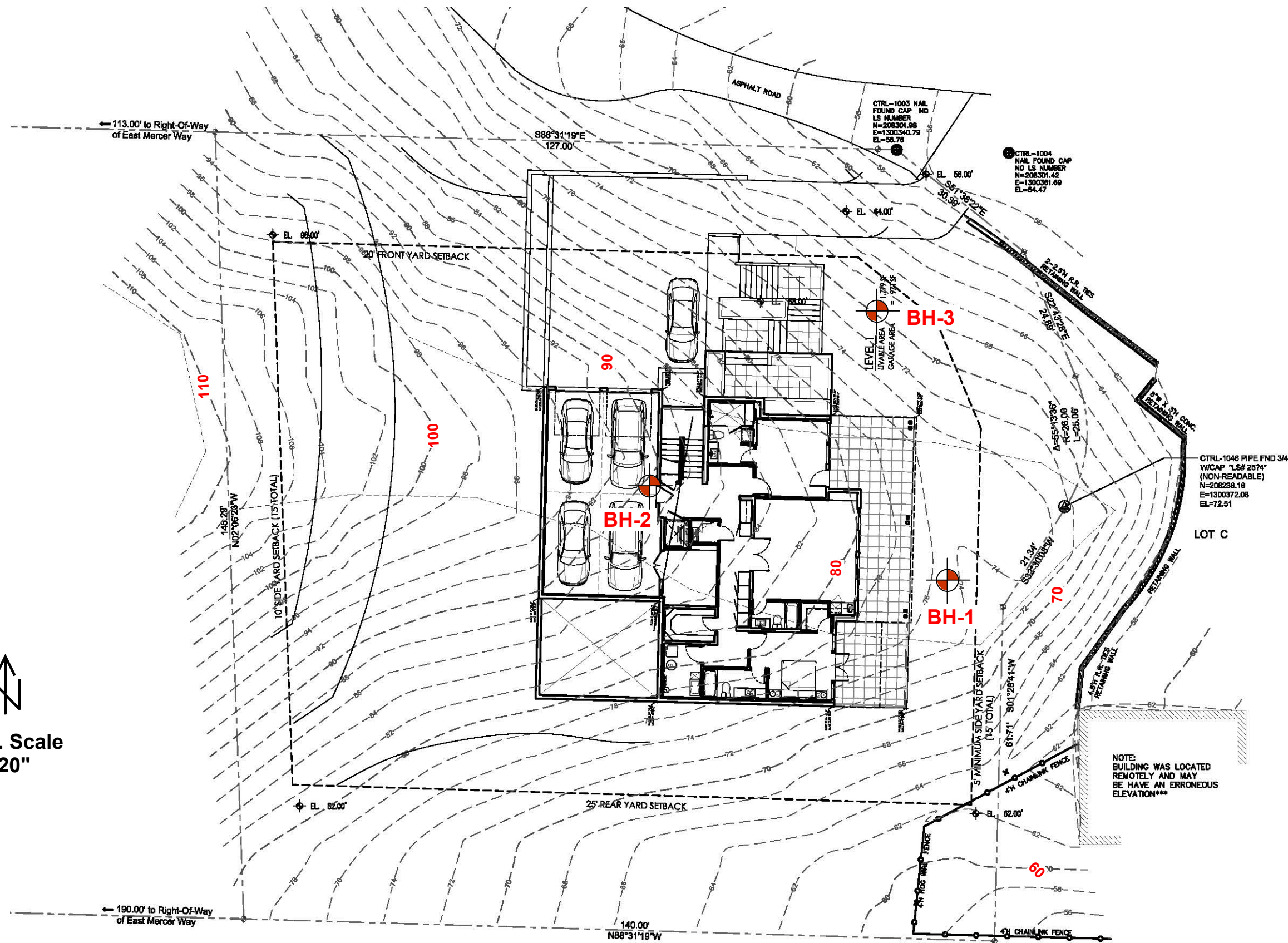

Basemap based on Site Plan by Studio 19 Architects dated December 9, 2014.

Legend:

BH-1 Approx. Boring Location

| | | | |
|--|---|----------------------------------|--------------|
| | Proposed Development 4634 E Mercy Way Mercer Island, Washington | SITE AND EXPLORATION PLAN | |
| | | Project No. 14-128 | Figure No. 2 |

APPENDIX A

SUMMARY TEST BORING LOGS

RELATIVE DENSITY / CONSISTENCY

| SAND / GRAVEL | | | SILT / CLAY | | |
|---------------|--------------|------------------------------|-------------|--------------|--|
| Density | SPT N-values | Approx. Relative Density (%) | Consistency | SPT N-values | Approx. Undrained Shear Strength (psf) |
| Very Loose | <4 | <15 | Very Soft | <2 | <250 |
| Loose | 4 to 10 | 15 - 35 | Soft | 2 to 4 | 250 - 500 |
| Med. Dense | 10 to 30 | 35 - 65 | Med. Stiff | 4 to 8 | 500 - 1000 |
| Dense | 30 to 50 | 65 - 85 | Stiff | 8 to 15 | 1000 - 2000 |
| Very Dense | >50 | 85 - 100 | Very Stiff | 15 to 30 | 2000 - 4000 |
| | | | Hard | >30 | >4000 |

UNIFIED SOIL CLASSIFICATION SYSTEM

| MAJOR DIVISIONS | | GROUP DESCRIPTIONS | |
|--|---------------------|--------------------------|--------------------------|
| Gravel 50% or more of the coarse fraction retained on the #4 sieve. Use dual symbols (eg. GP-GM) for 5% to 12% fines. | GRAVEL (<5% fines) | | GW: Well-graded GRAVEL |
| | GRAVEL (>12% fines) | | GP: Poorly-graded GRAVEL |
| | | | GM: Silty GRAVEL |
| Sand 50% or more of the coarse fraction passing the #4 sieve. Use dual symbols (eg. SP-SM) for 5% to 12% fines. | SAND (<5% fines) | | GC: Clayey GRAVEL |
| | SAND (>12% fines) | | SW: Well-graded SAND |
| | | | SP: Poorly-graded SAND |
| Silt and Clay 50% or more passing #200 sieve | | | SM: Silty SAND |
| | | | SC: Clayey SAND |
| | Liquid Limit < 50 | | ML: SILT |
| | | | CL: Lean CLAY |
| | | | OL: Organic SILT or CLAY |
| | Liquid Limit > 50 | | MH: Elastic SILT |
| | | CH: Fat CLAY | |
| | | OH: Organic SILT or CLAY | |
| Highly Organic Soils | | | PT: PEAT |

TEST SYMBOLS

for In Situ and Laboratory Tests listed in "Other Tests" column.

- ATT Atterberg Limit Test
- Comp Compaction Tests
- Con Consolidation
- DD Dry Density
- DS Direct Shear
- %F Fines Content
- GS Grain Size
- Perm Permeability
- PP Pocket Penetrometer
- R R-value
- SG Specific Gravity
- TV Torvane
- TXC Triaxial Compression
- UCC Unconfined Compression

SYMBOLS

Sample/In Situ test types and intervals

- 2-inch OD Split Spoon, SPT (140-lb. hammer, 30" drop)
- 3.25-inch OD Split Spoon (300-lb hammer, 30" drop)
- Non-standard penetration test (see boring log for details)
- Thin wall (Shelby) tube
- Grab
- Rock core
- Vane Shear

- Notes:**
- Soil exploration logs contain material descriptions based on visual observation and field tests using a system modified from the Uniform Soil Classification System (USCS). Where necessary laboratory tests have been conducted (as noted in the "Other Tests" column), unit descriptions may include a classification. Please refer to the discussions in the report text for a more complete description of the subsurface conditions.
 - The graphic symbols given above are not inclusive of all symbols that may appear on the borehole logs. Other symbols may be used where field observations indicated mixed soil constituents or dual constituent materials.

DESCRIPTIONS OF SOIL STRUCTURES

| | |
|---|---|
| Layered: Units of material distinguished by color and/or composition from material units above and below | Fissured: Breaks along defined planes |
| Laminated: Layers of soil typically 0.05 to 1mm thick, max. 1 cm | Slickensided: Fracture planes that are polished or glossy |
| Lens: Layer of soil that pinches out laterally | Blocky: Angular soil lumps that resist breakdown |
| Interlayered: Alternating layers of differing soil material | Disrupted: Soil that is broken and mixed |
| Pocket: Erratic, discontinuous deposit of limited extent | Scattered: Less than one per foot |
| Homogeneous: Soil with uniform color and composition throughout | Numerous: More than one per foot |
| | BCN: Angle between bedding plane and a plane normal to core axis |

COMPONENT DEFINITIONS

| COMPONENT | SIZE / SIEVE RANGE | COMPONENT | SIZE / SIEVE RANGE |
|----------------|------------------------|--------------|--------------------------------------|
| Boulder: | > 12 inches | Sand | |
| Cobbles: | 3 to 12 inches | Coarse Sand: | #4 to #10 sieve (4.5 to 2.0 mm) |
| Gravel | | Medium Sand: | #10 to #40 sieve (2.0 to 0.42 mm) |
| Coarse Gravel: | 3 to 3/4 inches | Fine Sand: | #40 to #200 sieve (0.42 to 0.074 mm) |
| Fine Gravel: | 3/4 inches to #4 sieve | Silt | 0.074 to 0.002 mm |
| | | Clay | <0.002 mm |

MONITORING WELL

- Groundwater Level at time of drilling (ATD)
- Static Groundwater Level
- Cement / Concrete Seal
- Bentonite grout / seal
- Silica sand backfill
- Slotted tip
- Slough
- Bottom of Boring

MOISTURE CONTENT

| | |
|-------|---------------------------|
| Dry | Dusty, dry to the touch |
| Moist | Damp but no visible water |
| Wet | Visible free water |

LOG KEY 13-104 LOGS.GPJ_PANGEO.GDT 6/18/13

| | | | |
|--------------|---|----------------------|--------|
| Project: | Proposed Development | Surface Elevation: | 75.0ft |
| Job Number: | 14-128 | Top of Casing Elev.: | |
| Location: | 4632 East Mercer Way, Mercer Island, WA | Drilling Method: | HSA |
| Coordinates: | Northing: , Easting: | Sampling Method: | SPT |

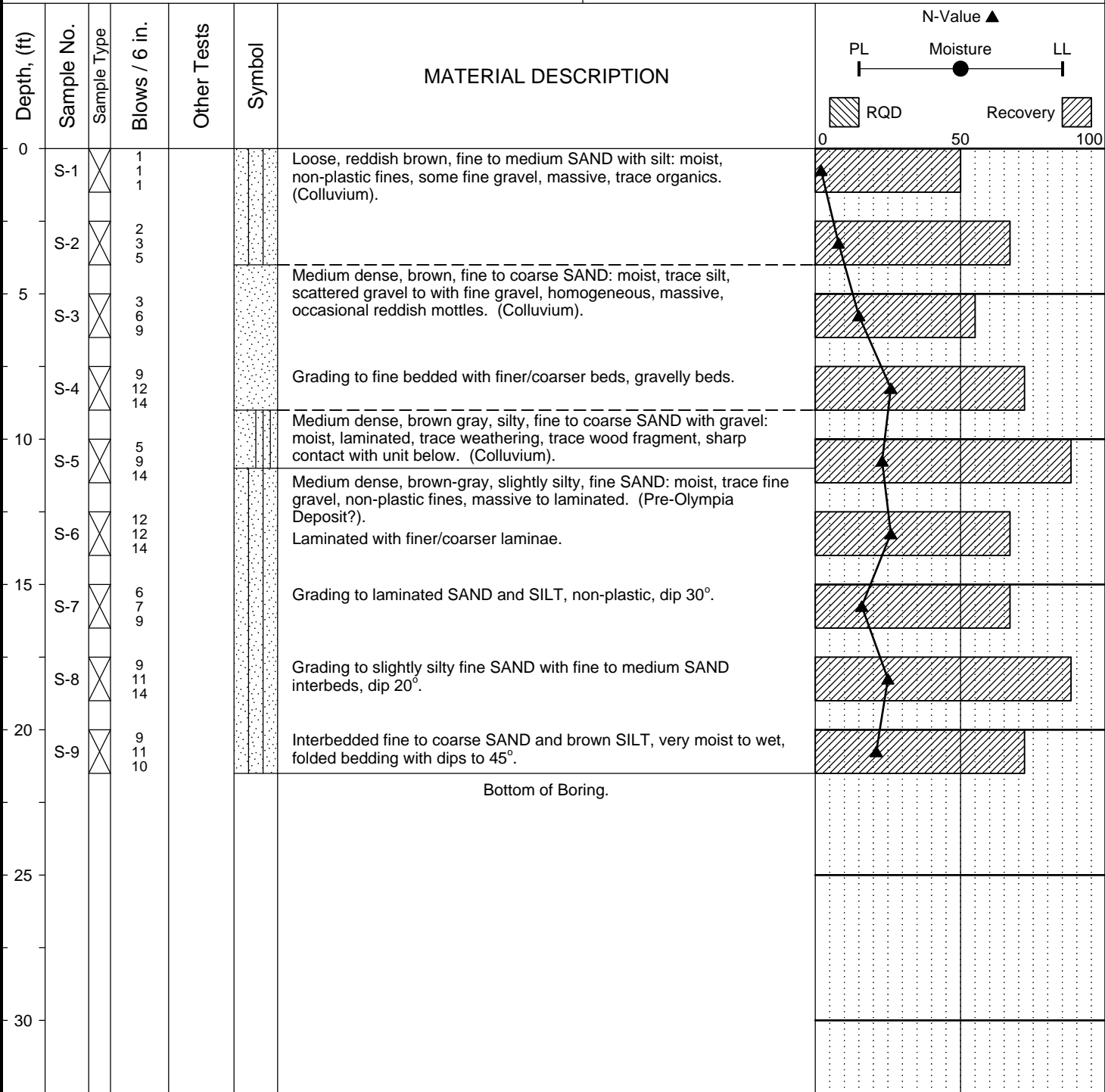

| | | |
|--------------------------|-------------|----------|
| Completion Depth: | 21.5ft | Remarks: |
| Date Borehole Started: | 5/16/14 | |
| Date Borehole Completed: | 5/16/14 | |
| Logged By: | S.Evans | |
| Drilling Company: | CN Drilling | |

| | | | |
|--------------|---|----------------------|--------|
| Project: | Proposed Development | Surface Elevation: | 89.0ft |
| Job Number: | 14-128 | Top of Casing Elev.: | |
| Location: | 4632 East Mercer Way, Mercer Island, WA | Drilling Method: | HSA |
| Coordinates: | Northing: , Easting: | Sampling Method: | SPT |

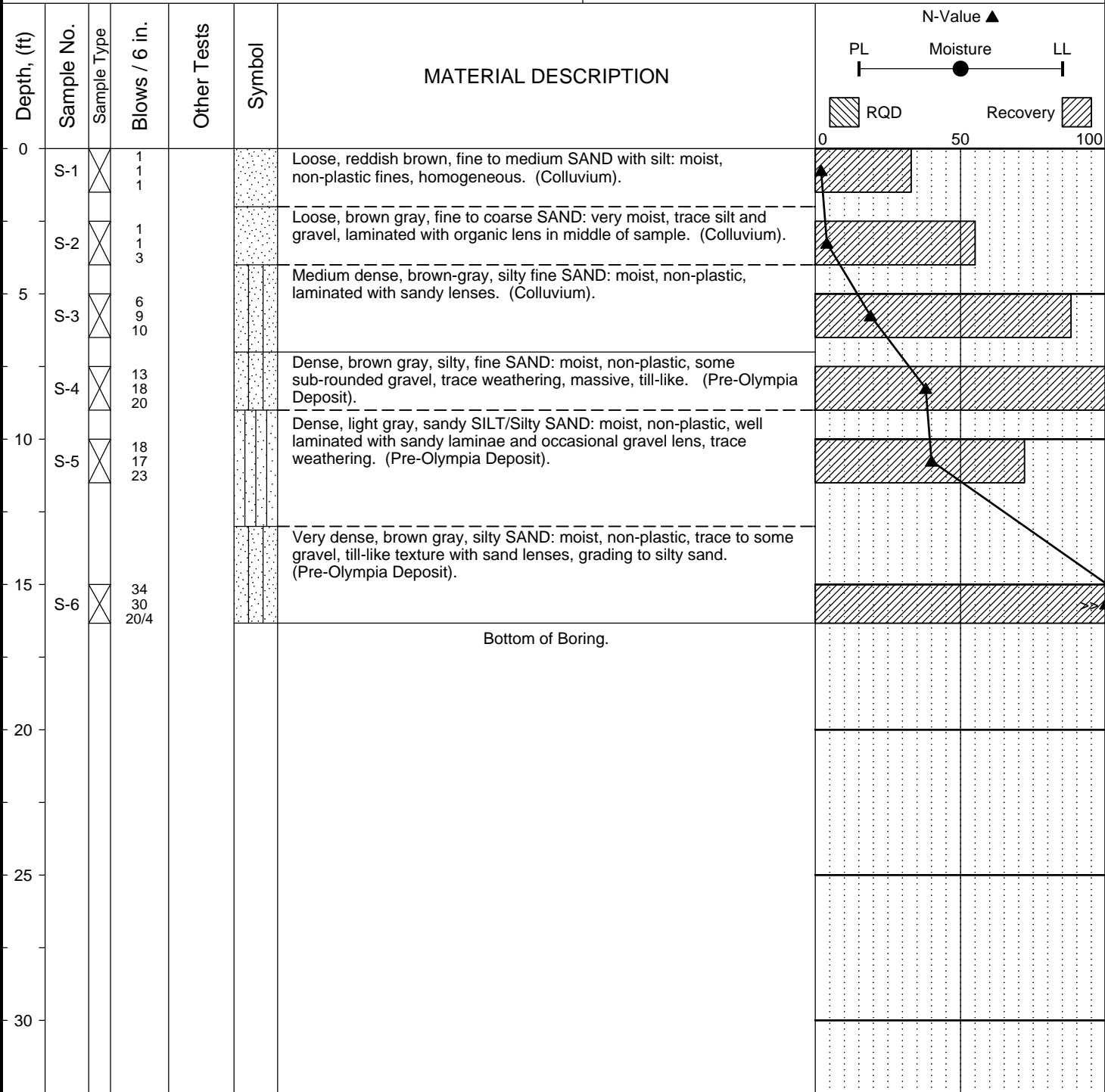

| | | |
|--------------------------|-------------|----------|
| Completion Depth: | 16.3ft | Remarks: |
| Date Borehole Started: | 5/16/14 | |
| Date Borehole Completed: | 5/16/14 | |
| Logged By: | S.Evans | |
| Drilling Company: | CN Drilling | |

| | | | |
|--------------|---|----------------------|--------|
| Project: | Proposed Development | Surface Elevation: | 70.0ft |
| Job Number: | 14-128 | Top of Casing Elev.: | |
| Location: | 4632 East Mercer Way, Mercer Island, WA | Drilling Method: | HSA |
| Coordinates: | Northing: , Easting: | Sampling Method: | SPT |

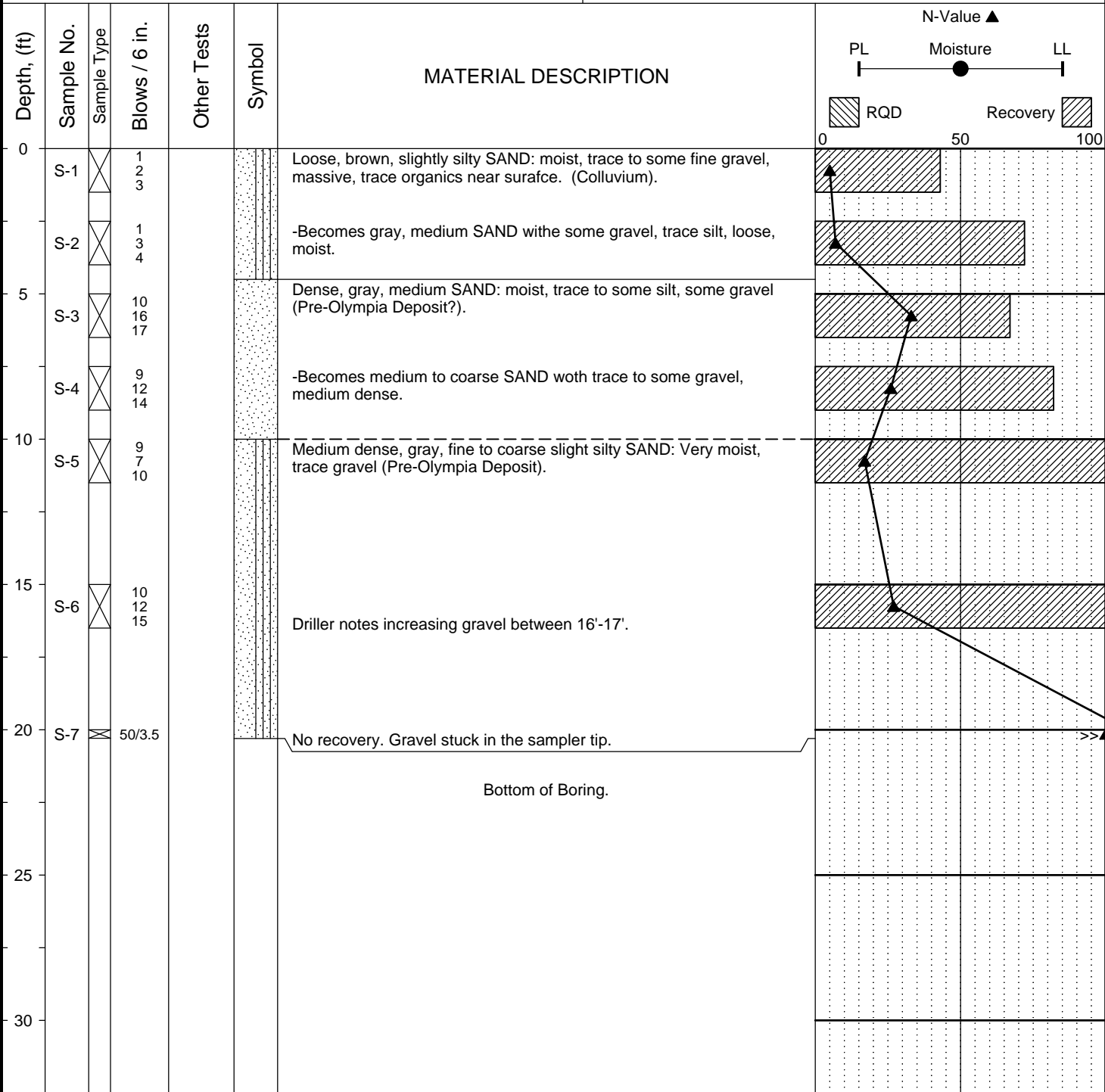

| | | |
|--------------------------|-------------|----------|
| Completion Depth: | 20.3ft | Remarks: |
| Date Borehole Started: | 6/2/14 | |
| Date Borehole Completed: | 6/2/14 | |
| Logged By: | HMX | |
| Drilling Company: | CN Drilling | |

June 1, 2016
File No. 14-128.200

Barcelo Homes, LLC
32505 138th Place SE
Auburn, WA 98092
Attn: Bogdan Maksimchuk

**Subject: Response to Review Comments and Statement of Risk
Proposed Single-Family Residence
4634 E Mercer Way, Mercer Island, WA**

Dear Mr. Maksimchuk,

This letter responds to City of Mercer Island's review comments dated May 11, 2016. The following are our responses to the review comments related to the geotechnical aspects of the project.

1. Friction Coefficient Between Foundations and Subgrade Soils

The design footings will be 5 to 15 feet below the existing grade, and the foundation subgrade will consist of medium dense to very dense, sandy soils based on the borings. Additionally, the footing subgrade soils will be compacted to a dense condition if needed. If we conservatively use a soil friction angle of 34 degree, it will yield a friction coefficient of more than 0.4 including a factor of safety of 1.5. We have been using this friction coefficient for similar soil conditions for projects throughout Puget Sound areas.

2. 1H:1V Temporary Sloped Cut West of West Building Wall

The planned 1H:1V cut west of the west building wall will be about 12 to 20 feet below the existing grade. The anticipated soils will be native, very dense silty sand (till-like). As such, it is our opinion that the soil conditions are adequate for temporary sloped 1H:1V cuts, and even steeper cuts are feasible.

3. Soil Bearing along South and East Building Walls

The design footing bottom along the east and south building walls will be about 5 feet below the existing grade, and the foundation subgrade will consist of medium dense, sandy soils based on the borings. The footing subgrade soil will be compacted to a dense condition if needed. Based on the soil conditions and provided that PanGEO is retained to conduct geotechnical monitoring during construction, in our opinion, an allowable soil bearing pressure of 2,500 psf can be adequately achieved.

4. Geotechnical Plan Review and Statement of Risk

We reviewed the geotechnical engineering aspects of the current plans for the above-referenced project. Our review includes Architectural Plan Sheets G0.01, A1.01 through A9.04 last revised on May 29, 2016 by Studio 19 Architects, Civil Plan Sheets 1 through 6 last revised on May 25, 2016 by Litchfield Engineering, and Structural Plan Sheets S1 through S11 last revised on May 30, 2016 by Tecinstruct LLC. In general, it appears that the plans reviewed had substantially incorporated the geotechnical recommendations presented in our revised geotechnical report dated February 2, 2015, and report addendum dated February 4, 2016.

We understand that the site is mapped as geologic hazard areas, specifically as steep slopes and potential landslide, erosion, and seismic hazard areas. Per Mercer Island City Code Section 19.07.060.D.2, development within geologic hazard areas and critical slopes may occur if the geotechnical engineer provides a statement of risk with supporting documentation indicating that one of the following conditions can be met:

- a. The geologic hazard area will be modified, or the development has been designed so that the risk to the lot and adjacent property is eliminated or mitigated such that the site is determined to be safe; or
- b. An evaluation of site specific subsurface conditions demonstrates that the proposed development is not located in a geologic hazard area; or

- c. Development practices are proposed for the alteration that would render the development as safe as if it were not located in a geologic hazard area; or
- d. The alteration is so minor as not to pose a threat to the public health, safety, and welfare.

Based on the results of our geotechnical evaluation, the site is underlain by dense glacial soil at relatively shallow depths and it is our opinion that the site is stable in its existing condition. The overall site stability will be greatly improved for the post-construction condition after soldier pile walls are constructed. As such, it is our opinion that the proposed development meets the criterion (c) above, as the foundation elements designed and constructed per our recommendations should adequately mitigate potential geologic hazards from impacting the subject and surrounding properties. The adequacy of the temporary erosion and sediment control measures should be carefully monitored during construction, especially in the wet season, by a qualified professional and will need to be modified as necessary according to the site and weather conditions. Permanent erosion control measures including landscape and hardscape installations will effectively mitigate the risk of erosion in the long term.

CLOSURE

We trust that the information presented herein meets your need at this time. Please call if you have any questions.

Sincerely,



Michael H. Xue, P.E.
Senior Geotechnical Engineer

July 19, 2016
File No. 14-128.200

Barcelo Homes, LLC
32505 138th Place SE
Auburn, WA 98092
Attn: Bogdan Maksimchuk

Subject: Statement of Risk
Proposed Single-Family Residence
4634 E Mercer Way, Mercer Island, WA

Dear Mr. Maksimchuk,

As requested, we reviewed the geotechnical engineering aspects of the latest plans for the above-referenced project. Our review includes Architectural Plan Sheets G0.01, G0.02, A1.01 through A9.04 last revised on July 14, 2016 by Studio 19 Architects, Civil Plan Sheets 1 through 6 last revised on May 25, 2016 by Litchfield Engineering, and Structural Plan Sheets S1 through S11 last revised on July 13, 2016 by Tecinstruct LLC. In general, it appears that the plans reviewed had substantially incorporated the geotechnical recommendations presented in our revised geotechnical report dated February 2, 2015, and report addendum dated February 4, 2016.

We understand that the site is mapped as geologic hazard areas, specifically as steep slopes and potential landslide, erosion, and seismic hazard areas. Per Mercer Island City Code Section 19.07.060.D.2, development within geologic hazard areas and critical slopes may occur if the geotechnical engineer provides a statement of risk with supporting documentation indicating that one of the following conditions can be met:

- a. The geologic hazard area will be modified, or the development has been designed so that the risk to the lot and adjacent property is eliminated or mitigated such that the site is determined to be safe; or

Statement of Risk

Proposed Single-Family Residence – 4634 East Mercer Way, Mercer Island, WA

July 19, 2016

- b. An evaluation of site specific subsurface conditions demonstrates that the proposed development is not located in a geologic hazard area; or
- c. Development practices are proposed for the alteration that would render the development as safe as if it were not located in a geologic hazard area; or
- d. The alteration is so minor as not to pose a threat to the public health, safety, and welfare.

Based on the results of our geotechnical evaluation, the site is underlain by dense glacial soil at relatively shallow depths and it is our opinion that the site is stable in its existing condition. The overall site stability will be greatly improved for the post-construction condition after soldier pile walls are constructed. As such, it is our opinion that the proposed development meets the criterion (c) above, as the foundation elements designed and constructed per our recommendations should adequately mitigate potential geologic hazards from impacting the subject and surrounding properties. The adequacy of the temporary erosion and sediment control measures should be carefully monitored during construction, especially in the wet season, by a qualified professional and will need to be modified as necessary according to the site and weather conditions. Permanent erosion control measures including landscape and hardscape installations will effectively mitigate the risk of erosion in the long term.

CLOSURE

We trust that the information presented herein meets your need at this time. Please call if you have any questions.

Sincerely,



Michael H. Xue, P.E.
Senior Geotechnical Engineer

August 12, 2016
File No. 14-032.200

Barcelo Homes, LLC
32505 138th Place SE
Auburn, WA 98092
Attn: Bogdan Maksimchuk

**Subject: Geotechnical Report Addendum
Evaluation of Surcharge Load on the Soldier Pile Wall
Proposed Single-Family Residence
4634 E Mercer Way, Mercer Island, WA**

Dear Mr. Maksimchuk,

Based on the City's review comment, PanGEO performed additional analysis to evaluate the potential surcharge load on the lower soldier pile wall due to the upper soldier pile wall. The following sections present a summary of our additional analysis and conclusion for the soldier pile wall design.

Based on the current design plans, the upper and lower walls are spaced approximately 15 feet (see attached page 1). We selected a critical upper wall section with a height of 12.3 feet for our analysis (see page 2). Soil parameters are assigned based on the subsurface data for L-Pile analysis. We then performed L-Pile analyses to obtain the point of fixity of the soldier piles. The summary results of L-Pile analyses for the 12.3 feet and 8.9 feet high upper wall are included on pages 3 and 4 of the attachment. Based on the lateral pile analysis, the point of the fixity of the soldier pile is found to be at 23.8 feet for the 12.3 high wall section and 19.3 feet for the 8.9 high wall section. Based on the point of fixity, the approximate passive wedge of the upper wall is plotted on page 1, and it appears the passive wedge intercept the very top of the lower wall (approx. upper 1.6'). As a result, there will be some surcharge load on the lower wall due to the passive wedge of the upper wall.

As an attempt to quantify this surcharge load, we reviewed AASHTO bridge design specification and other documents. According to AASHTO, the group effect for 2nd row for a pile spacing of 5 times the pile diameter is 0.85 (see page 5). The spacing between upper and lower walls are about 6 times the soldier pile diameter. As such, the group effect factor will be between 0.85 and 1. Page 6 of the attachment also shows that the moved/disturbed soil in front of the pile is approximately ellipse in shape in plan view.

In summary, based on results of our analysis, there is likely small surcharge near the top of the lower wall due to mobilization of the passive wedge of the upper wall. To account for the impact of this surcharge due to upper wall passive pressure, we recommend to increase the active earth pressure of the lower wall 15% for the soldier pile design in areas it has a parallel upper soldier pile wall. It is our opinion that this simplified and conservative approach should be adequate to account for the potential impact of the upper wall on the lower wall.

CLOSURE

We trust that the information presented herein meets your need at this time. Please call if you have any questions.

Sincerely,



Michael H. Xue, P.E.
Senior Geotechnical Engineer

Attachment: Summary Results of Engineering Analysis

4634 E MERCER WAY
SOLDIER PILE WALL SECTION

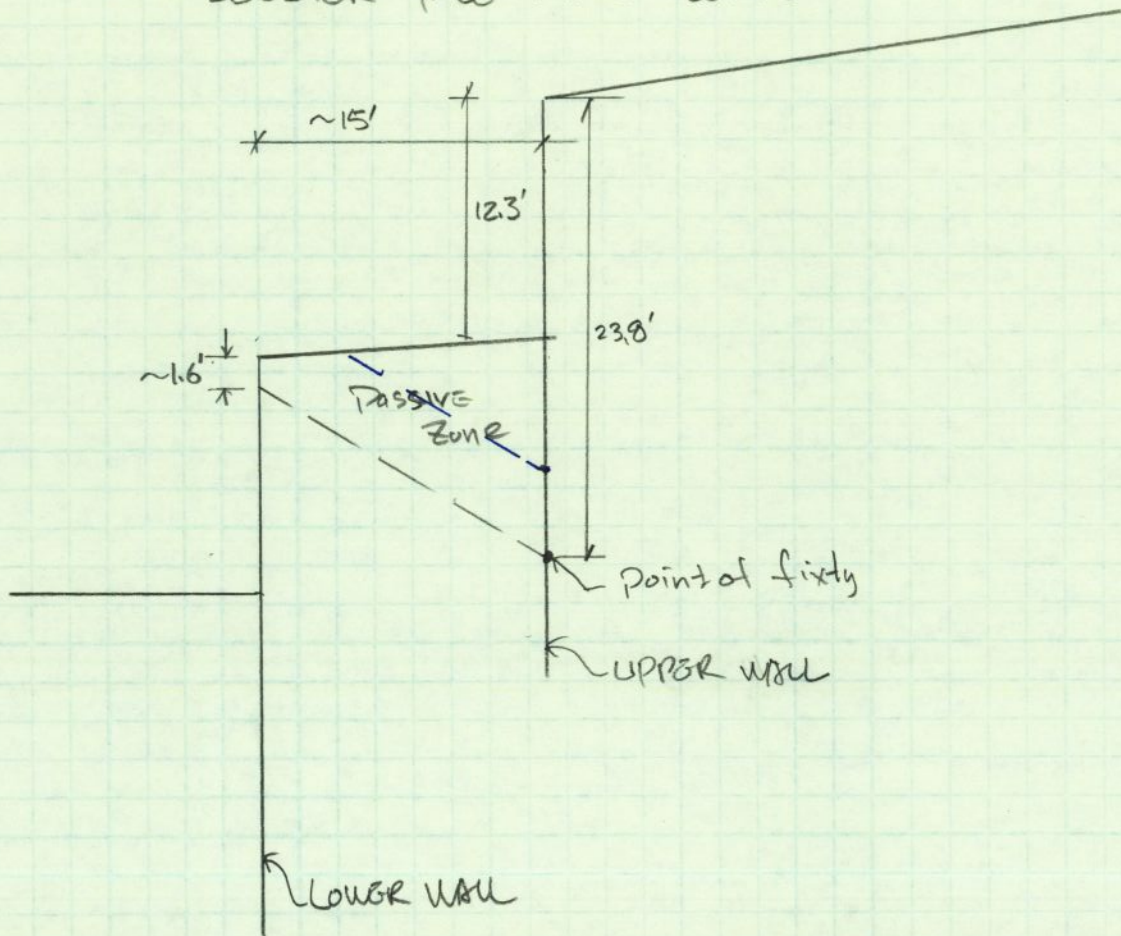

SCALE: 1" = 10'

L-pile (A11pile) Analysis section

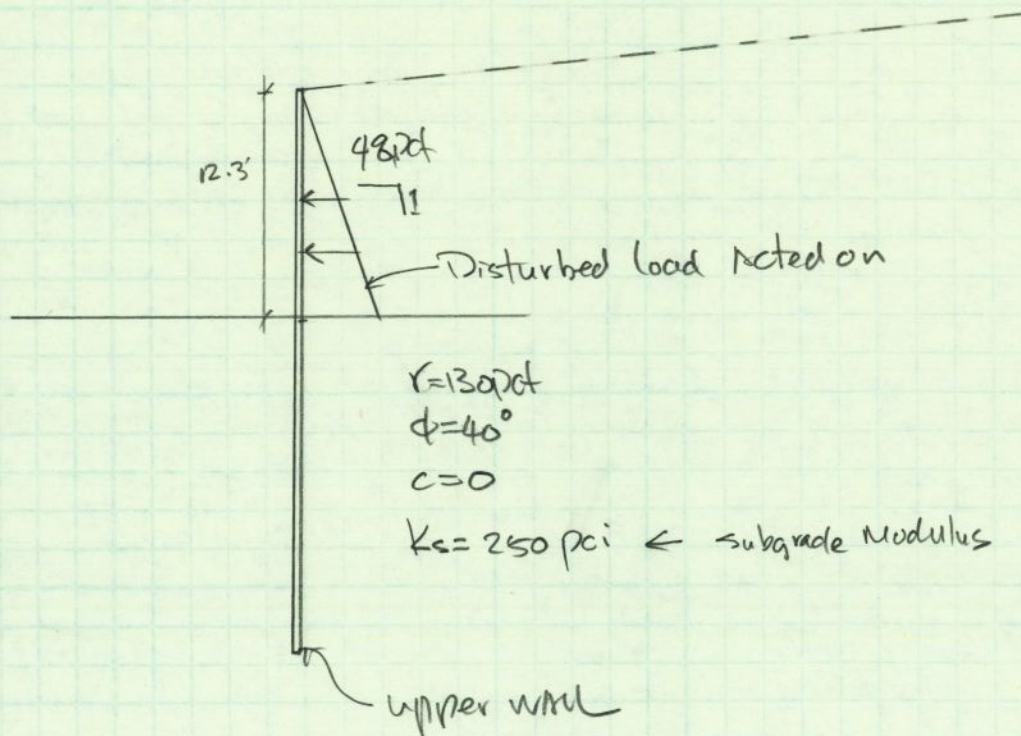

SOIL PROFILE TO FIND POINT OF FIXITY

PILE DEFLECTION & FORCE VS DEPTH

Single Pile, Khead=2, Kbc=1

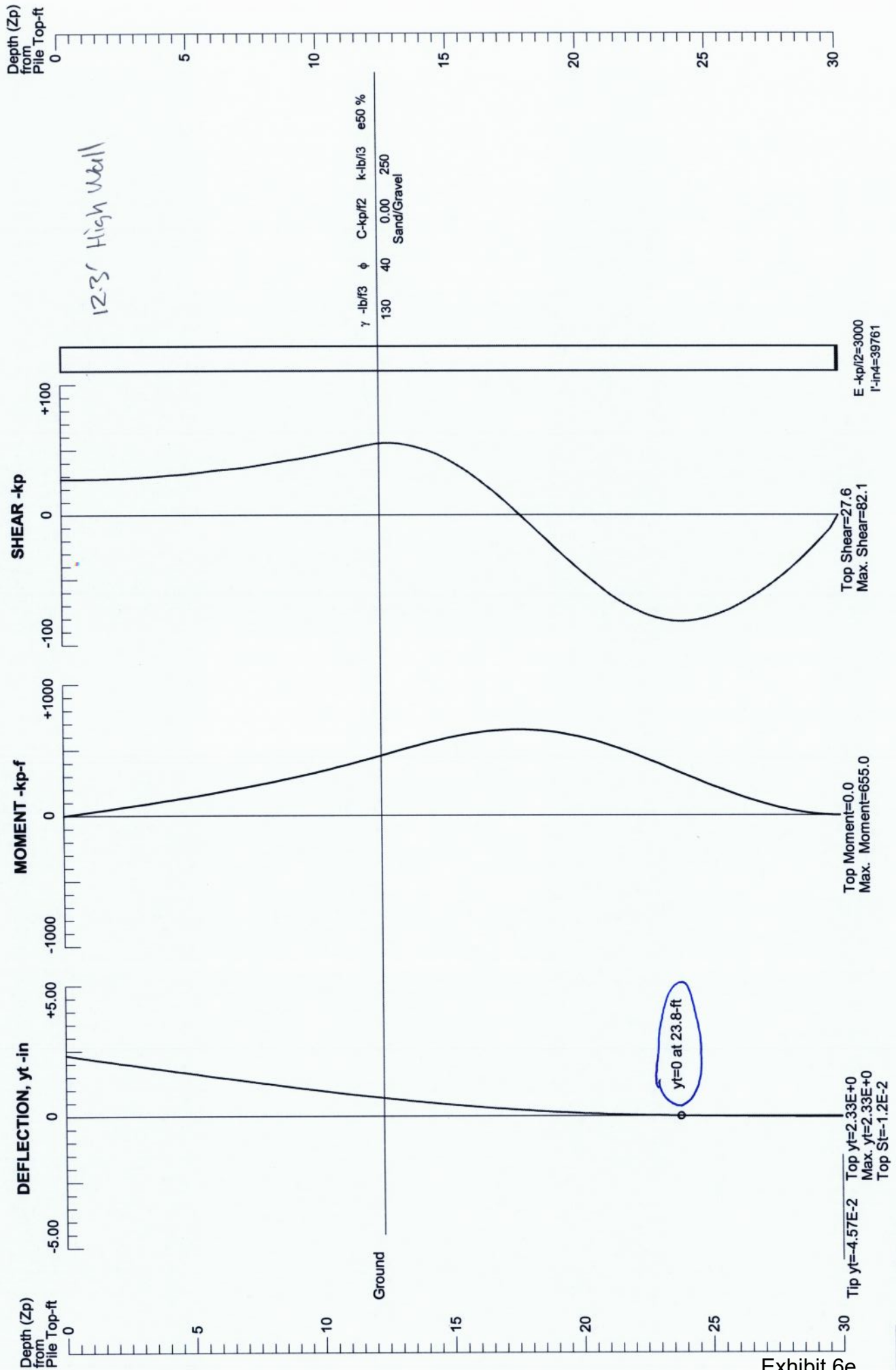

Exhibit 6e
1763



Figure 2

PILE DEFLECTION & FORCE vs DEPTH

Single Pile, Khead=2, Kbc=1

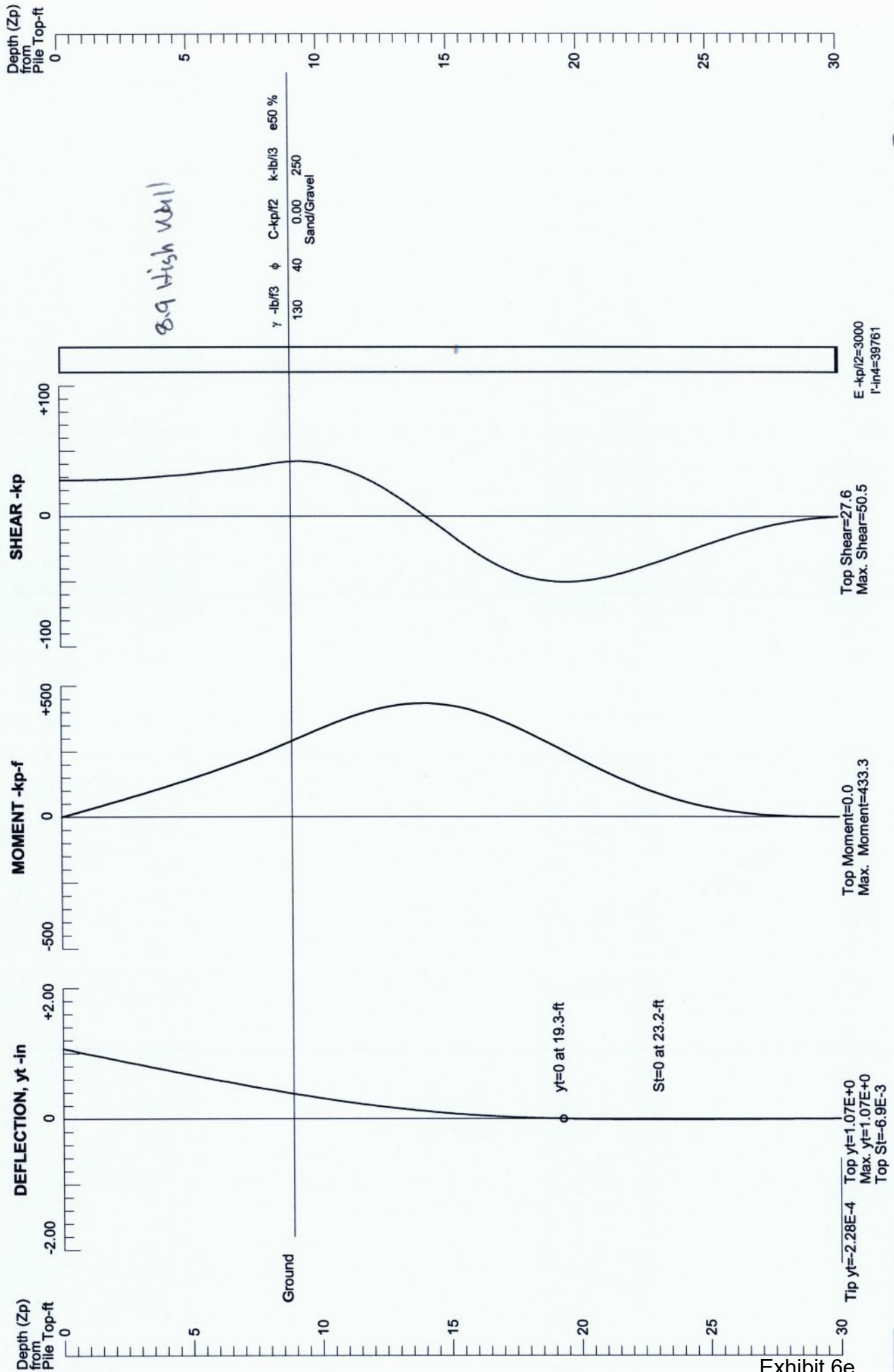

PG4

Figure 2



Table 10.7.2.4-1—Pile P-Multipliers, P_m , for Multiple Row Shading (averaged from Hannigan et al., 2006)

| Pile CTC spacing (in the direction of loading) | P-Multipliers, P_m | | |
|--|----------------------|-------|------------------|
| | Row 1 | Row 2 | Row 3 and higher |
| $3B$ | 0.8 | 0.4 | 0.3 |
| $5B$ | 1.0 | 0.85 | 0.7 |

Loading direction and spacing shall be taken as defined in Figure 10.7.2.4-1. If the loading direction for a single row of piles is perpendicular to the row (bottom detail in the Figure), a group reduction factor of less than 1.0 should only be used if the pile spacing is $5B$ or less, i.e., a P_m of 0.8 for a spacing of $3B$, as shown in Figure 10.7.2.4-1.

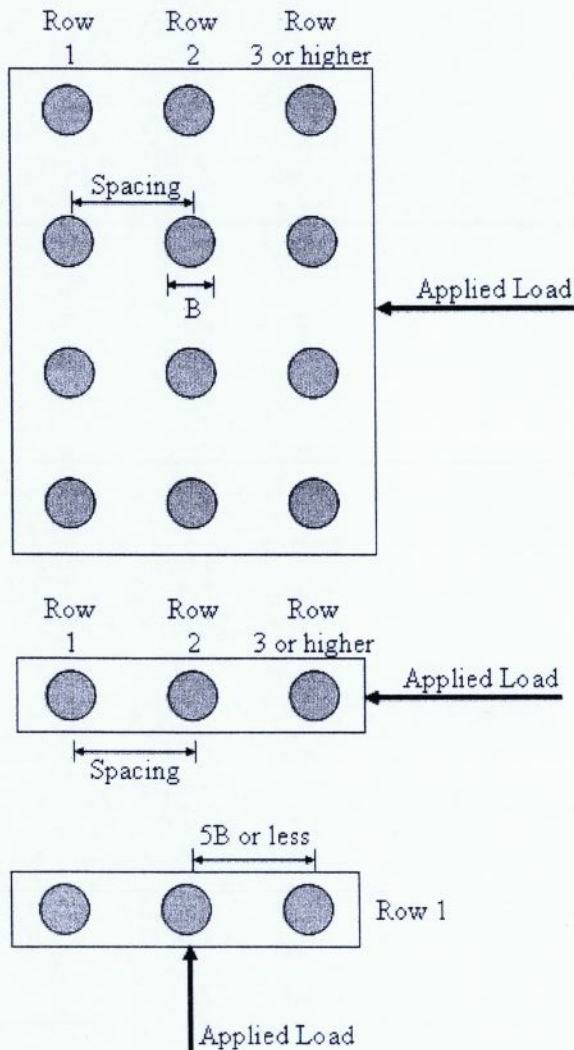

Figure 10.7.2.4-1—Definition of Loading Direction and Spacing for Group Effects

Since many piles are installed in groups, the horizontal resistance of the group has been studied and it has been found that multiple rows of piles will have less resistance than the sum of the single pile resistance. The front piles “shade” rows that are further back.

The P-multipliers, P_m , in Table 10.7.2.4-1 are a function of the center-to-center (CTC) spacing of piles in the group in the direction of loading expressed in multiples of the pile diameter, B . The values of P_m in Table 10.7.2.4-1 were developed for vertical piles only.

Lateral load tests have been performed on pile groups, and multipliers have been determined that can be used in the analysis for the various rows. Those multipliers have been found to depend on the pile spacing and the row number in the direction of loading. To establish values of P_m for other pile spacing values, interpolation between values should be conducted.

The multipliers are a topic of current research and may change in the future. Values from recent research have been tabulated by Hannigan et al. (2006).

Note that these P - y methods generally apply to foundation elements that have some ability to bend and deflect. For large diameter, relatively short foundation elements, e.g., drilled shafts or relatively short stiff piles, the foundation element rotates rather than bends, in which case strain wedge theory (Norris, 1986; Ashour et al., 1998) may be more applicable. When strain wedge theory is used to assess the lateral load response of groups of short, large diameter piles or shaft groups, group effects should be addressed through evaluation of the overlap between shear zones formed due to the passive wedge that develops in front of each shaft in the group as lateral deflection increases. Note that P_m in Table 10.7.2.4-1 is not applicable if strain wedge theory is used.

Batter piles provide a much stiffer lateral response than vertical piles when loaded in the direction of the batter.

The expression for W is

$$W = \gamma \frac{bH^2}{2} \tan \alpha \dots\dots\dots(3-5)$$

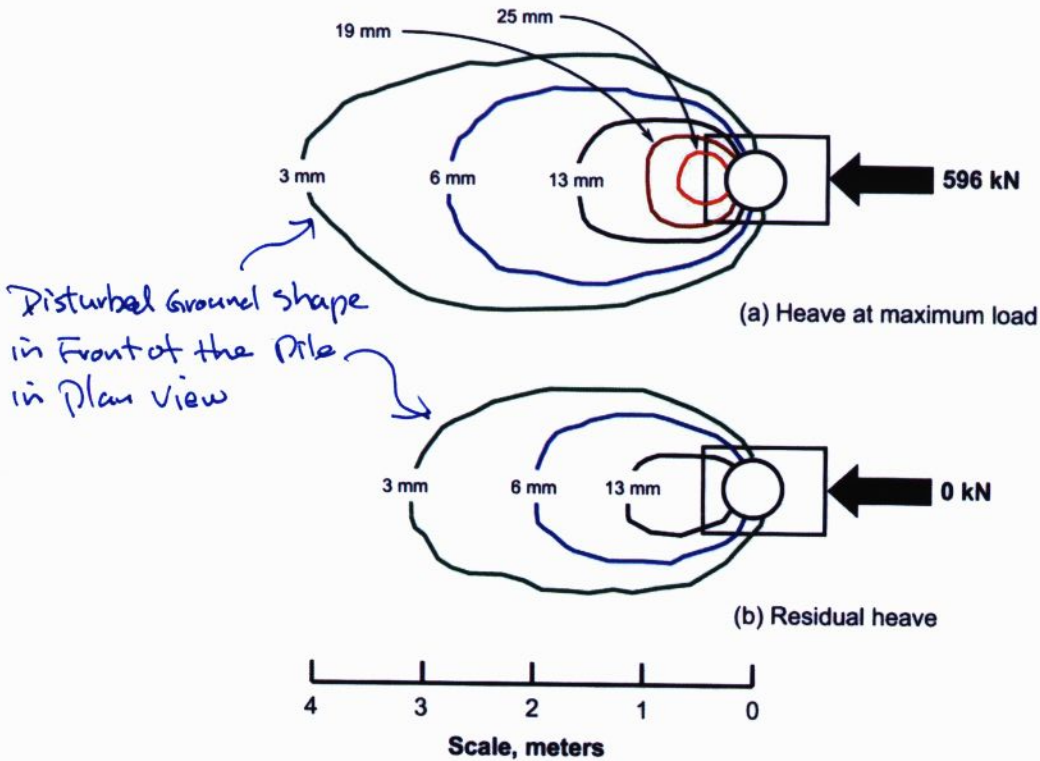

Figure 3-7 Measured Profiles of Ground Surface Heave Near Piles Due to Static Loading. (a) Ground Surface Heave at Maximum Load, (b) Residual Ground Surface Heave

where:

- γ = unit weight of soil,
- b = width (diameter) of pile, and
- H = depth of wedge.

The resultant shear force on the inclined plane F_s is

$$F_s = c_u bH \sec \alpha \dots\dots\dots(3-6)$$

May 2, 2018
File No. 14-128.200

Mr. Paul Maksimchuk
MAKSLAND LLC
223 SW 327th Place
Federal Way, WA 98023

**Subject: Response to Review Comments
Proposed Single-Family Residence
4634 E Mercer Way, Mercer Island, WA**

Dear Mr. Maksinchuk,

This letter responds to City of Mercer Island's review comments dated October 26, 2017 regarding Critical Area Determination for the above project. It should be noted that our response to the review comments is limited to the geotechnical aspect of the comments. Our response to the comments is summarized below.

1. Impact of the Proposed Construction on the Private Street

We understand that the only access to the subject site is a private street from East Mercer Way (see Figure 1). Based on the review of available King County iMap and City GIS maps, the private street generally descends from the East Mercer Way to the subject site with gradients up to about 10 to 15 percent with a total elevation difference of about 75 feet. The private street is an asphalt paved road (see Plates 1 and 2). PanGEO personnel visited the site several times in the last winter to observe the conditions along the private street and the slopes along the street. Some cracks were observed on the asphalt pavement surface. These cracks are approximately parallel to the roadway. In our opinion, the pavement cracks were likely caused by a combination of poor pavement subgrade condition, pavement fatigue, and slow creep of roadway subgrade. It is also our opinion that the pavement cracks are likely developed over a long period of time.



Plate 1. View of the upper (west) section of private street, approximately looking west.



Plate 2. View of the upper (mid-west) section of private street, approximately looking west.

The proposed construction will require truck traffic to export the excavated soils and import the structural fill if needed. Concrete trucks will also need to use the private street. In order to reduce the potential impacts on the street, we recommend the trucks accessing the subject site on the private street have a maximum load of 5 yards each truck. In our opinion, based on the anticipated truck traffic, the reduced truck load may potentially cause minor additional roadway subgrade creep and pavement cracks or enlarging the existing cracks. However, it is our opinion that the anticipated truck traffic with reduced truck load will not likely have adverse impacts on the stability of the roadway and slopes along the road. Additionally, we recommend that monitoring points be established along the roadway to observe the roadway performance during trucking period. Daily monitoring is recommended during the mass trucking period.

In summary, it is our professional opinion that the anticipated truck traffic with reduced truck load will not likely adversely impact the stability of the private street and surrounding steep slopes. Furthermore, it is also our opinion that the potential minor additional roadway subgrade creep and pavement cracks will not constitute alteration of the steep slopes as defined in Chapter 19.16 MICC.

2. Wood Wall on 4640 East Mercer Way

A wood wall about 4½ feet is located about 20 feet to the east property line on 4640 East Mercer Way property. The proposed construction area is located approximately 30 feet outside of the 1H:1V line projected from the bottom of the wood wall. Based on the soil conditions at the site, the distance of the wood wall and the proposed construction area, it is our professional opinion that the proposed construction will not have adverse impacts on the existing wood wall and the adjacent property to the east. However, we recommend that monitoring points be established on the existing wood wall and monitoring be conducted during earthwork.

CLOSURE

We trust that the information presented herein meets your need at this time. Please call if you have any questions.

Sincerely,



5/2/2018

Michael H. Xue, P.E.
Senior Geotechnical Engineer

From: Marc McGinnis
To: [Robin Proebsting](#)
Subject: JN18426 Geotechnical Assessment Related to Development of 4634 East Mercer Way
Date: Tuesday, September 4, 2018 1:25:05 PM

Robin,

This email is a summary of my geotechnical conclusions related to the question of “whether or not the construction impacts (i.e. construction vehicle traffic, including dump trucks) constitute an alteration of a steep slope.” This is the limited scope of my geotechnical assessment. In order to make this assessment, I reviewed the documents you have provided, including the geotechnical engineering study by PanGeo, responses to City comments by studio 19 architects and PanGeo, and the various letters of public comment by several neighboring property owners. Additionally, I reviewed the previous geotechnical reports and assessments that our firm has completed for lots in the immediate vicinity. On August 23, 2018 I visited the site to observe the conditions along the private road extending between East Mercer Way, and the dead-end located to the east of the currently-vacant site that is to be developed with a new home.

Under the Mercer Island Municipal Code:

Alteration: Any human-induced action which adversely impacts the existing condition of the area, including grading, filling, dredging, draining, channeling and paving (including construction and application of gravel).

Steep Slope: Any **slope** of 40 percent or greater calculated by measuring the vertical rise over any 30-foot horizontal run. **Steep slopes** do not include artificially created **cut slopes** or **rockeries**.

Based on my observations, there are steep slope areas along both the upslope and downslope sides of the private access road over much of its length. However, the slopes immediately adjacent to the road have been created by excavation and filling for the road’s construction. At most locations, these steep manmade slopes are not tall enough to be classified as Steep Slopes under the Mercer Island Municipal Codes. An exception to this is along the common section of driveway extending southward from East Mercer Island, where the fill for the road’s original construction was placed at the top of a natural steep slope that would be tall enough to be classified as a Steep Slope.

The filled, eastern (downslope) portion of the common section of the road displays signs of cracking and settling. Based on my observations, and previous experience with both private and public roads exhibiting similar conditions, the cracking and settling is most likely due to ongoing consolidation of fill that was not properly placed and compacted when the road was originally built. The cracking and settlement is not due to instability in the native slope below the manmade fill. This road has withstood heavy truck and equipment traffic resulting from the construction of the approximately 10 to 12 residences that are accessed by this private road. Several of these houses are more than 4,000 square feet in size, and King County Assessor records indicate that at least two of them are more than 7,000 square feet in size. This traffic would have included numerous dump trucks, concrete trucks, and lumber trucks. Additionally, it appears that other heavy trucks, such as garbage trucks and moving trucks, have utilized the road over the years. We are not aware of any load restrictions that have been instituted on this road, which would affect emergency vehicles.

From my observations, the additional vehicle traffic for the construction of the proposed residence

should not adversely affect the stability of the steep natural slope along the private road. This is particularly true if the vehicles are to be limited to a capacity of 5 cubic yards, as indicated in the May 2, 2018 letter from PanGeo.

Please let me know if you have any questions on this assessment.

Marc R. McGinnis, P.E.
GEOTECH CONSULTANTS, INC.
2401 – 10th Avenue East
Seattle, WA 98102
(425) 747-5618 (Office)
(425) 260-1116 (Mobile)

From: [Don Cole](#)
To: [Robin Proebsting](#)
Cc: [Evan Maxim](#)
Subject: CAO17-007/SEP18-021 staff report review
Date: Friday, February 15, 2019 3:58:06 PM

Hello Robin,

Per our discussion regarding the subject project, I agree with Michele that the geotechnical review could be approved with the condition that the items within the letter from Michele Lorilla (dated 12/21/18) are satisfactorily resolved during the building permit process.

Please let me know if I can be of further assistance.

Don Cole, Building Official
Community Planning & Development
City of Mercer Island

9611 SE 36th St. Mercer Island, WA 98040-3732

| | |
|--|--|
| 206.275.7605 phone | 206.275.7726 fax |
| 206.275.7701 voicemail | 206.275.7730 inspections |
| don.cole@mercergov.org | www.mercergov.org |
| www.mybuildingpermit.com | Building Permit Information |

Notice of Public Disclosure: This e-mail account is public domain. Any correspondence from or to this e-mail account may be public record. Accordingly, this e-mail, in whole or in part, may be subject to disclosure pursuant to RCW 42.56, regardless of any claim of confidentiality or privilege by an external party.

MEMORANDUM

Date: December 21, 2018

To: Robin Proebsting

From: Michele Lorilla, P.E.

Re: 4634 East Mercer Way, Mercer Island

These comments are based on a review of the PanGeo, October 5, 2017 geotechnical report and the drawings submitted in the REV1-SUB2 project file.

Based on a review of these documents the following comments are provided:

1. The permanent soldier pile walls being located to the north and west of the residence are the key components to the stability of the proposed development and the upslope property. Geotechnical subsurface information is required at the location of these walls to provide the basis of the wall design as well as for the soil strength parameters to be used in slope stability analyses required for this site.
2. Temporary and permanent site configurations should be thoroughly analyzed to include locations upslope and downslope of the walls. The results of these slope stability analyses to be provided in the final design geotechnical report.
3. The structural drawing (S-11) indicates that the upper soldier pile wall height is 12'4". The wall height could be increased to reduce or eliminate the need for permanent cuts above the wall. This would reduce the amount of disturbance to the slope above the wall, thereby reducing the potential for instability above the wall.
4. The final design geotechnical engineering report should be less generic. Specific design recommendations should be presented not just alluded to, e.g., on page 10 of the report the engineer states "For lower wall located within the influence zone of the passive pressure of the upper wall, additional surcharge should be included in the design of the lower wall in addition to the active earth pressure of the lower wall." However, no actual recommended surcharge values are presented in the report.

The report goes on to say that a 15-foot wide bench in front of the soldier pile wall was assumed for the passive pressures provided. "If the ground surface in front of the wall needs to be sloped.....the passive resistance in the sloped portion of the ground should be ignored or reduced for design calculations." Yet no recommended reduction is provided. The area where the 15-foot wide bench will not be present should be clearly defined so that there is no confusion as to which piles are to be designed with a reduced passive resistance.

5. Page 14 of the geotechnical report includes a reference to monitoring pin piles. There are no pin piles recommended for this project. However, PanGeo should include monitoring of the installation of the soldier pile walls; the temporary excavation for and installation of the Ultra block wall and the permanent cuts and fills across the site.
6. The structural calculations of the walls should be provided for review so that the wall loading surcharges and reductions can be verified.
7. The project drawings need to be consistent throughout the plan set: citing the most recent report dates, using identical wall elevations, updating wall design loadings, updating temporary and final grading plans. Examples of the inconsistencies or issues remaining to be addressed are presented below:

The civil drawing noted as Site Improvement Plan (Sheet 3 of 6) by Litchfield Engineering last revised 8/3/2018, has wall elevations contrary to the architectural and structural drawings.

This same plan (Sheet 3 of 6) indicates wall footing drains behind the soldier pile walls. This is not appropriate since the soldier pile walls do not have footings. However, capturing surface water runoff above walls should be considered and included in the final design drawings.

The temporary excavation plan on Sheet 5 of 6 by Litchfield Engineering last revised 8/3/2018, indicates a temporary 1H:1V cut in front of the soldier pile wall with a 5-foot wide bench in front of the wall. The structural drawing (S-11, by tecinstruct LLC, last revised 8/12/2016) does not indicate a bench. Whatever will be the worst-case condition (no bench) should be assessed for stability by the geotechnical engineer. If no bench is anticipated, the temporary excavation plan should also be revised.

Also, on Sheet 5 of 6 at the ends of the soldier pile wall, a permanent 1H:1V cut is indicated on the plans. The geotechnical engineer should provide specific permanent cut slope recommendations at these locations or the wall should be extended to reduce or eliminate the proposed cuts.



Delineation / Mitigation / Restoration / Habitat Creation / Permit Assistance

9505 19th Avenue S.E.
Suite 106
Everett, Washington 98208
(425) 337-3174
Fax (425) 337-3045

CRITICAL AREA STUDY

FOR

**Four Season Homes, LLC – 4634 E Mercer Way SFR
City of Mercer Island, WA**

Wetland Resources, Inc. Project #17067

Prepared By

Wetland Resources, Inc.
9505 19th Avenue SE, Suite 106
Everett, WA 98208
(425) 337-3174

Prepared For

Four Season Homes, LLC
11319 24th Street East
Edgewood, WA 98372

First Submittal: July 3, 2018
Revision 1: October 1, 2018

(this page intentionally left blank)

TABLE OF CONTENTS

1.0 PROPOSED PROJECT 1
 1.1 PROJECT LOCATION 1
 1.2 PROJECT DESCRIPTION..... 1
2.0 REGULATORY SETTING 2
 2.1 SHORELINE SUBSTANTIAL DEVELOPMENT PERMIT EXEMPTION DISCUSSION..... 2
 2.2 MICC CRITICAL AREAS COMPLIANCE..... 3
3.0 DELINEATION METHODOLOGY 4
 3.1 LIMIT OF STUDY 4
 3.2 CRITICAL AREAS CLASSIFICATION..... 4
 3.3 WETLAND DETERMINATION AND DELINEATION 4
 3.4 WETLAND DETERMINATION DISCUSSION 5
 3.5 WATERCOURSE DETERMINATION 5
 3.6 WATERCOURSE DETERMINATION DISCUSSION 5
 3.7 WILDLIFE HABITAT CONSERVATION DISCUSSION 6
4.0 WETLAND AND STREAM DELINEATION REPORT 6
 4.1 REVIEW OF EXISTING INFORMATION 6
 4.2 WATERCOURSE DETERMINATION FINDINGS..... 8
5.0 USE OF THIS REPORT 10
6.0 REFERENCES 11

TABLES AND FIGURES

TABLE 1: MAPPED SOILS IN THE PROJECT AREA..... 6
FIGURE 1: VICINITY MAP (IMAGE SOURCE: KING COUNTY) 1
FIGURE 2: POTENTIAL FISH USE 9

Appendices

Appendix A: Critical Area Study Map (Sheet 1/1)

Executive Summary

Project Name: Four Season Homes, LLC – 4634 E Mercer Way SFR

Location: The subject property is located at 4634 E Mercer Way, in the city of Mercer Island.

Client:

Four Season Homes, LLC
11319 24th Street East
Edgewood, WA 98372

Property Owner:

Same as client

Wetland Resources Staff: John Laufenberg, PWS (Principal Ecologist) and Niels Pedersen (Senior Ecologist).

Critical Areas Determination: Regulated features located within the project area (subject property and stormwater easement) include Lake Washington and a City-mapped Type 3 watercourse (Stream A) located along the south property line. Lake Washington requires a 25-foot structure setback (measured from elevation 18.6' NAVD 88). Stream A requires a 35-foot protective buffer.

A portion of the project occurs within the regulated shorelands area (200 feet from the ordinary high water mark of Lake Washington). No wetlands were observed in the vicinity of proposed development.

Proposed Project: The applicant proposes to construct a single-family residence on an undeveloped parcel. The project requires clearing, excavating, and grading to prepare the site. The proposal includes an ABS stormwater pipe laid on the ground surface within the stormwater easement, which discharges to an outfall pad approximately ten feet from the OHWM of Lake Washington.

Critical Areas Impacts and Mitigation: The proposed single-family residence is located outside of the 35-foot buffer associated with Stream A. Proposed development within 35 feet of the watercourse includes an ABS pipe laid on the ground surface, which conveys stormwater generated within the subject property towards Lake Washington. The pipe discharges to a 3' x 8' outfall pad that will be installed as an erosion control measure.

The existing condition of the stormwater easement is maintained lawn or English ivy. The stormwater pipe will be elevated where it crosses the Stream A, to avoid flow alterations. No native vegetation will be removed or impacted as a result of this proposal. Any critical area buffer impacts resulting from this project are considered trivial or discountable; no mitigation is proposed.

1.0 PROPOSED PROJECT

1.1 PROJECT LOCATION

Basin: Puget Sound

Sub-Basin: Water Resource Inventory Area (WRIA) 8 – Cedar/Sammamish River

Watershed: Lake Washington

Sub-Watershed: Mercer Island

The proposed project occurs within the parcel located at 4634 E Mercer Way, in the city of Mercer Island, Washington. *Wetland Resources, Inc.* (WRI) performed multiple site investigations in the spring of 2017 and the summer of 2018. The purpose of the site visits was to identify critical areas on and in proximity to the project.

Access to the site is from the west via E Mercer Way. Vegetation within the subject property consists of typical Puget Lowlands second-growth forest species, with the exception of English ivy in the understory. Topography within the subject property slopes to the south towards a shallow ravine, and east towards Lake Washington. A seasonal stream (Stream A) forms in the shallow ravine in the southern portion of the property, flowing east towards Lake Washington.

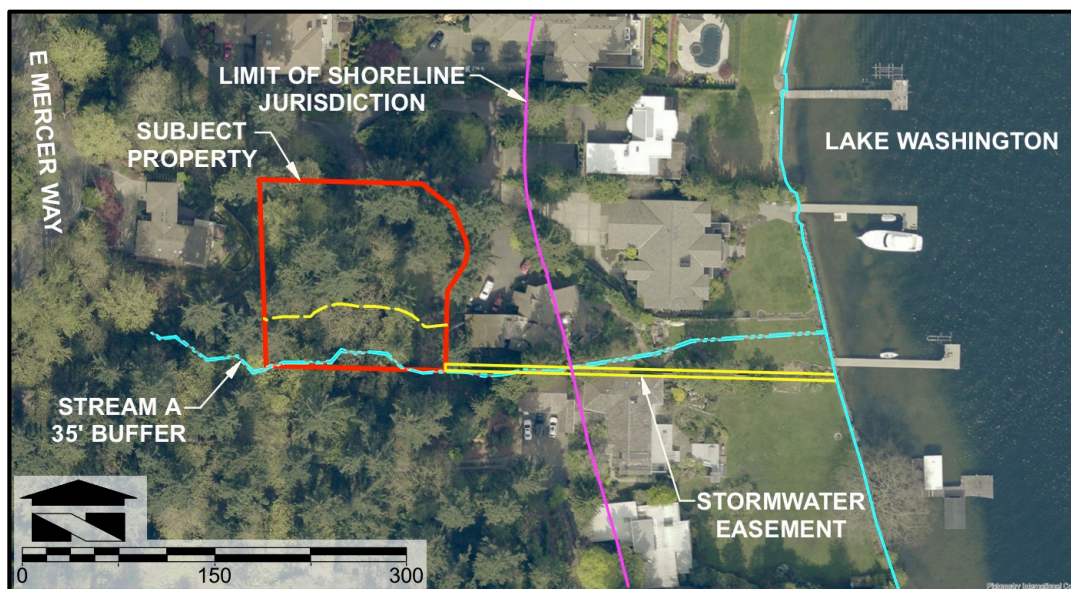

Figure 1: Vicinity Map (image source: King County)

1.2 PROJECT DESCRIPTION

The applicant proposes to construct a new single-family residence within an undeveloped parcel. The residence will be constructed outside of the 35-foot buffer associated with Stream A. Development within 35 feet of the watercourse includes an ABS stormwater pipe that will be placed on the ground surface. The pipe enters the 35-foot buffer in the southeast portion of the site, and is routed to an existing stormwater easement within the adjacent property to the east (at the southeast corner of the subject property). The pipe will then be routed to the east towards Lake Washington. The pipe crosses Stream A approximately 200 feet from the ordinary high water mark (OHWM) of Lake Washington. Metal collars will anchor the pipe to the ground surface in several locations, and the pipe will be elevated where it crosses Stream A (to avoid flow alterations). The pipe has been located to avoid impacts to native vegetation; the pipe will rest on either English

ivy or maintained lawn. The pipe will be installed by hand at grade, will not require impacts to native vegetation, and will not have any measurable effect on critical area functions. The outfall pad is a 3'x8' grouted rock splash pad, and was designed to eliminate erosion potential. The pad will be constructed within an existing grass lawn.

The applicant asserts that the proposed development in the buffer of Stream A will not negatively impact critical area functions due to the small footprint at grade, the existing vegetated condition of the site (aggressive non-native vegetation or maintained lawn), and the design of the outfall pad to eliminate erosion concerns. No compensatory mitigation is proposed for this project.

2.0 REGULATORY SETTING

2.1 SHORELINE SUBSTANTIAL DEVELOPMENT PERMIT EXEMPTION DISCUSSION

A portion of the stormwater easement is located within 200 feet of the OHWM of Lake Washington, and is therefore within shoreline jurisdiction. The shoreline environment designation is Urban Residential (source: Appendix F Mercer Island Shoreline Master Program). The stormwater plan/conveyance is correctly classified as a normal appurtenance to the development of a single-family residence, as defined by the Washington Administrative Code (WAC). The plan/conveyance would also be correctly classified as an accessory use, as defined by the Mercer Island Municipal Code (MICC). Based on these classifications, the proposed development is exempt from shoreline substantial development permit requirements. More detailed discussion is provided below.

2.1.1 WAC Shoreline Exemption Discussion

WAC 173-27-040 provides narrowly construed exemption criteria for shoreline substantial development permits. WAC 173-27-040(2)(g) specifically relates to this project, and reads as follows:

Construction on shorelands by an owner, lessee or contract purchaser of a single-family residence for their own use or for the use of their family, which residence does not exceed a height of thirty-five feet above average grade level and which meets all the requirements of the state agency or local government having jurisdiction thereof, other than requirements imposed pursuant to chapter 90.58 RCW. "Single-family residence" means a detached dwelling designed for and occupied by one family including those structures and developments within a contiguous ownership which are a normal appurtenance. An "appurtenance" is necessarily connected to the use and enjoyment of a single-family residence and is located landward of the ordinary high water mark and the perimeter of a wetland. On a statewide basis, normal appurtenances include a garage; deck; driveway; utilities; fences; installation of a septic tank and drainfield and grading which does not exceed two hundred fifty cubic yards and which does not involve placement or fill in any wetland or waterward of the ordinary high water mark. Local circumstances may dictate additional interpretations of normal appurtenances which shall be set forth and regulated within the applicable master program. Construction authorized under this exemption shall be located landward of the ordinary high water mark;

The applicant asserts that the proposed single-family residence meets all exemption criteria provided in WAC 173-27-040(2)(g), specifically:

- height above grade (less than thirty-five feet),
- local jurisdiction requirements (MICC exemption criteria),
- the definition of single-family residence (detached dwelling for use by one family),
- contiguous ownership (parcel and stormwater easement only),

- location relative to the OHWM (landward) and wetlands (outside the perimeter),
- the definition of normal appurtenance (including utilities), and
- the absence of fill placement in wetlands or waterward of the OHWM.

2.1.2 MICC Shoreline Exemption Discussion

Pursuant to MICC 19.07.110(D) *Table A*, Single-family dwellings, including accessory uses and structures are considered categorically exempt development activities. Accessory uses are defined by the MICC as “a use customarily incidental and accessory to the principal use of the site...” It is the applicant’s assertion that stormwater conveyance is correctly classified as an accessory use, and is therefore covered under the single-family residential exemption provisions of the MICC.

2.2 MICC CRITICAL AREAS COMPLIANCE

New utility facilities are an allowed alteration within critical area buffers if they meet the standards set forth in MICC 19.07.030(a)-(d). The following narrative re-states all subsections of MICC 19.07.030 (bold text, indented), with the applicant’s response to each citation immediately following (normal font, justified).

a. Construction is consistent with best management practices,

Response: BMPs are proposed as part of the TESC Plan prepared for this project.

b. The facility is designed and located to mitigate impacts to critical areas consistent with best available science,

Response: Mitigation is defined in the MICC as the use of any or all of the following actions: avoiding the impact, minimizing the impact, rectifying the impact, eliminating the impact over time, compensating for the impact, and monitoring the impact. The proposed project includes placement of an ABS pipe on the ground surface to convey stormwater. The proposed project meets the mitigation sequencing provisions of the MICC, as described below.

Avoidance

The only way to avoid project impacts completely is to discharge outside of the watercourse buffer. This option was explored early on in the development process, and was ultimately deemed infeasible for two reasons: the downstream area below the buffer’s edge is a steep slope; discharging to the slope could reduce slope stability, and additional stormwater inputs to Stream A could exacerbate existing drainage issues within the neighboring property.

Minimization

The standard practice for installing this pipe is trenching. Impacts have been minimized by placing the pipe on the ground surface.

Rectification/Elimination

The proposal eliminates impacts over time because cleaning/flushing the pipe can be accomplished without any disturbance to the critical area buffer.

Compensation/Monitoring

As stated in this report, critical areas impacts are extremely limited. Compensation is not appropriate in this case.

c. Impacts to critical areas are mitigated to the greatest extent reasonably feasible so there is no net loss of critical area functions; and

Response: As described in this report, placement of an ABS pipe on the ground surface within the buffer of Stream A (in maintained lawn and over aggressive non-native English ivy) does not impact critical areas. No net loss of critical area functions is expected, and therefore no mitigation is required.

The code official may require a critical area study or restoration plan for this allowed alteration.

Response: Noted.

3.0 DELINEATION METHODOLOGY

3.1 LIMIT OF STUDY

The proposed project occurs within one 0.49-acre parcel and a five-foot wide stormwater easement on the adjacent parcel to the east (4640 E Mercer Way). Lack of legal access to additional parcels in the vicinity of the subject property prevents Wetland Resources, Inc. (WRI) staff from performing routine wetland/OHWM determinations in surrounding areas. Critical area boundaries depicted outside of the accessible parcels are estimated using best professional judgment, and are based on visual observation from the edge of legal access.

3.2 CRITICAL AREAS CLASSIFICATION

Critical areas were classified in accordance with the standards set forth in MICC 19.07.070 for watercourses, section 19.07.080 for wetlands, 19.07.090 for wildlife habitat conservation areas, and 19.07.110 for shoreline areas. Identification of geologic hazard areas is beyond the scope of this report. Buffers are measured horizontally in a landward direction from the critical area boundary.

3.3 WETLAND DETERMINATION AND DELINEATION

Wetland boundaries were determined using the routine determination approach described in the Corps of Engineers Wetlands Delineation Manual (Environmental Laboratory 1987) and the Regional Supplement to the Corps of Engineers Wetland Delineation Manual: Western Mountains, Valleys, and Coast Region (Version 2.0) (U.S. Army Corps of Engineers 2010), as required by MICC 19.07.080(A). Under the routine methodology, the process for making a wetland determination is based on three steps:

- 1.) Examination of the site for hydrophytic vegetation (species present and percent cover);
- 2.) Examination of the site for hydric soils;
- 3.) Determining the presence of wetland hydrology

The following criteria must be met in order to make a positive wetland determination.

3.3.1 Vegetation Criteria

The Corps Manual and 2010 Regional Supplement define hydrophytic vegetation as “*the assemblage of macrophytes that occurs in areas where inundation or soil saturation is either permanent or of sufficient frequency and duration to influence plant occurrence.*” Field indicators are used to determine whether the hydrophytic vegetation criteria have been met. Examples of these indicators include, but are not limited to, the rapid test for hydrophytic vegetation, a dominance test result of greater than 50%, and/or a prevalence index score less than or equal to 3.0.

3.3.2 Soils Criteria

The 2010 Regional Supplement (per the National Technical Committee for Hydric Soils) defines hydric soils as soils “*that formed under conditions of saturation, flooding, or ponding long enough during the growing season to develop anaerobic conditions in the upper part.*” Field indicators are used to determine whether a given soil meets the definition for hydric soils. Indicators are numerous and include, but are not limited to, presence of a histosol or histic epipedon, a sandy gleyed matrix, depleted matrix, and redoximorphic depressions.

3.3.3 Hydrology Criteria

Wetland hydrology encompasses all hydrologic characteristics of areas that are periodically inundated or have soils saturated to the surface for a sufficient duration during the growing season. Areas with evident characteristics of wetland hydrology are those where the presence of water has an overriding influence on the characteristics of vegetation and soils due to anaerobic and chemically reducing conditions, respectively. The strongest indicators include the presence of surface water, a high water table, and/or soil saturation within at least 12 inches of the soil surface.

3.4 WETLAND DETERMINATION DISCUSSION

No wetlands were observed within or in the vicinity of the subject property during any of the site visits.

3.5 WATERCOURSE DETERMINATION

The OHWM of Stream A was determined based on the Ecology guidance document titled *Determining the Ordinary High Water Mark for Shoreline Management Act Compliance in Washington State*. Stream boundaries in off-site areas were estimated using a high-resolution aerial overlaid with fine-scale elevation contours generated from a 3x3 Digital Elevation Model of King County. On-site stream boundaries were delineated and surveyed by APS Survey and Mapping.

3.6 WATERCOURSE DETERMINATION DISCUSSION

City of Mercer Island GIS depicts one watercourse to the north of the subject property, and one to the south. The depicted alignment of the north channel meanders across the existing access road (labeled 4600 Block on Google Maps). WRI staff walked the entire length of the access road in search of evidence of a stream channel, or evidence of subsurface drainage (potential piped watercourse). No drains, catch basins, or manhole covers were observed. No surface channels were observed. It is apparent that the mapped watercourse to the north of the subject property is not present in the location depicted on the City of Mercer Island map.

Along the south property boundary, Stream A was first identified in 2017 during a routine field investigation. Narrow, braided scour marks were observed in a dense mat of English ivy at the low point of a shallow ravine within the subject property. These indicators of surface water are consistent with the definition of “Stream” presented in the Mercer Island City Code (MICC).

3.7 WILDLIFE HABITAT CONSERVATION DISCUSSION

Areas used by bald eagles for nesting, breeding, feeding and survival are designated by the City of Mercer Island as wildlife habitat conservation areas. No known bald eagle nests are located in the vicinity of the subject property.

4.0 WETLAND AND STREAM DELINEATION REPORT

WRI was contracted by Four Season Homes to delineate and catalogue regulated features within and in the vicinity of the subject property. No wetlands were observed in the study area. Two regulated features were observed: Lake Washington and a Type 3 watercourse (Stream A). These features are depicted in the attached critical area study map (See Appendix A). Lake Washington is a shoreline of statewide significance, and requires a 25-foot structure setback from the OHWM (survey-based, 18.6' NAVD 88). Stream A is a seasonal stream with faint indicators of bed and bank. The stream does not meet criteria for regulation as a fish-bearing stream using either WAC stream typing criteria (222-16-030), or standards established in section 19.07.070(A) of the MICC; Slope analysis based on LIDAR indicates that stream gradient exceeds 20 percent slope in the lower reaches. Stream A requires a 35-foot protective buffer.

4.1 REVIEW OF EXISTING INFORMATION

Prior to conducting the on-site investigations, public resources information was reviewed to gather background information on the project study area and surrounding areas in regards to wetlands, streams, and other critical areas.

4.1.1 USFWS National Wetlands Inventory

No wetlands are depicted in the vicinity of the project area.

4.1.2 King County Soils

The Natural Resources Conservation Service (NRCS) web soil survey and the 2014 national hydric soil list by state were used to identify soil types in the project area, and state their hydric properties. Kitsap silt loam is the only mapped soil type in the project area. The following table describes the hydric component percentage found in the mapped soil type. The likelihood that a given map unit is a hydric soil is partly based on the percentage of hydric components found in the soil type.

| Map Unit Name | Hydric Component | Component Percentage |
|------------------|------------------|----------------------|
| Kitsap silt loam | Bellingham | 3 |
| | Tukwila | 1 |
| | Seattle | 1 |

Table 1: Mapped Soils in the Project Area

4.1.3 Fish Presence

The Washington Department of Fish and Wildlife (WDFW), Pacific States Marine Fisheries Commission (PSMFC), and the Washington Dept. of Natural Resources (WADNR) are the primary agencies that provide publicly available information used for making fish presence determinations consistent with the water typing rules set forth in WAC 222-16-030. The following information represents the findings from each source.

4.1.4 WDFW SalmonScape Map Tool

SalmonScape is an online GIS database that contains publicly available resource information for fish population studies and general species distribution (both documented and modeled presence). SalmonScape does not depict stream A. Within Lake Washington, the following species are depicted:

- fall chinook (documented presence),
- coho salmon (documented presence),
- winter steelhead trout (documented presence),
- sockeye salmon (documented presence),
- bull trout (documented rearing),
- kokanee salmon (documented presence),

4.1.5 PSMFC StreamNet Map Tool

StreamNet is a fish distribution database maintained by the PSMFC as a regional clearinghouse for fish data. In the vicinity of the project area, fish presence is only depicted within Lake Washington. StreamNet states the presence of the following species:

- fall chinook (migration only)
- summer chinook (spawning and rearing)
- coho salmon (migration only)
- chum salmon (migration only)
- pink salmon (migration only)
- sockeye salmon (migration only)
- summer steelhead trout (migration only)
- winter steelhead trout (migration only)
- bull trout (migration only)

4.1.6 WDNR Forest Practices Activity Mapping Tool (FPAMT)

FPAMT is an online GIS database that aids the process of submitting a Forest Practices Permit application. The tool is useful for the purposes of this study because WADNR models fish presence. Stream A is not depicted by FPAMT. FPAMT states that the following species are known to occur within Lake Washington:

- fall chinook (migration)
- coho (migration only)
- sockeye salmon (migration only)
- winter steelhead (migration only)
- bull trout (rearing and migration)

4.1.7 City of Mercer Island Critical Areas

In the vicinity of the project area, the City of Mercer Island depicts two watercourses.

4.1.8 WDFW Priority Habitat and Species (PHS) Maps

WDFW PHS maps do not depict any priority habitat or species presence in the vicinity of the subject property.

4.2 WATERCOURSE DETERMINATION FINDINGS

4.2.1 Lake Washington

Jurisdiction: USACE, City of Mercer Island, WDFW, Ecology, DNR

Cowardin Class: Lacustrine, Limnetic, Unconsolidated Bottom

Classification: Shoreline of Statewide Significance

City of Mercer Island Setback Requirement: 25 feet

Lake Washington is a 21,600-acre waterbody that drains much of WRIA 8. Waterbodies that exceed 1,000 acres in total size are recognized as shorelines of statewide significance (WAC 173-20). The area extending 200 feet from the ordinary high water mark of Lake Washington is considered the shoreland area, and development within this zone is subject to the provisions of the Mercer Island Shoreline Master Program (MICC 17.09.110). In Mercer Island, Lake Washington requires a 25-foot structure setback, measured from elevation 18.6' (NAVD 88).

Lake Washington provides habitat for many aquatic species, including: bull trout, pink salmon, sockeye salmon, summer steelhead, winter steelhead, chum salmon, coho salmon, fall Chinook, and summer Chinook. Lake Washington is a primary association area for federally listed threatened and endangered species (chinook, bull trout).

4.2.2 Stream A

Jurisdiction: City of Mercer Island

Cowardin Class: Riverine, Intermittent, Streambed

Watercourse Type (MICC): 3

City of Mercer Island Standard Buffer Requirement: 35 feet

Stream A is a series of faint, braided scour marks found amongst a dense mat of English ivy within the subject property. The feature is located at the low point of a shallow ravine that slopes east towards Lake Washington. Surface water was not observed during any site visit, which indicates that the feature only flows during large precipitation events. Stream A exits the subject property at the southeast corner, flowing east into the adjacent property (4640 E Mercer Way). The stream was observed from within the subject property, and from the edge of legal access within the adjacent property to the east (within an existing five-foot wide stormwater easement).

Based on comparison with the King County Digital Elevation Model (DEM), it appears that the historic channel may travel through approximately the center of the adjacent property (4640 E Mercer Way). However, no evidence of a defined bed or bank was observed within the neighbor's property; the center of the property is a regularly maintained lawn.

Stream A is correctly classified as a Type 3 Watercourse, based on the definitions presented in MICC 19.07.070(A). Type 3 Watercourses have intermittent or seasonal flow, and are not used by fish. The MICC defines "fish use" as follows:

Those areas within a watercourse where live fish normally exist for spawning rearing and/or migration. "Fish use" may be presumed to occur in those reaches of watercourses that have year round flow, are accessible from Lake Washington to juvenile salmonid fish and have an average bed slope of less than 12 percent. "Fish use" shall not be presumed for (1) intermittent or seasonal reaches; (2) for reaches with an average bed slope of 12 percent or greater; (3) for reaches upstream from road culverts with a bottom slope of 10 percent or greater; or (4) reaches with greater than a 12-inch drop from the downstream invert of the culvert to the downstream pool elevation at ordinary high water. If the uppermost point of fish use cannot be identified with simple,

nontechnical observations, then the upper extent of fish use should be determined using the best professional judgment of a qualified professional after considering actual conditions and the physical abilities and capabilities of juvenile salmonid fish.

Fish use is presumed for watercourses that have year round flow, are accessible from Lake Washington, and have an average bed slope of less than 12 percent. Although Stream A is occasionally accessible from Lake Washington, it does not have year round flow, and average bed slope exceeds 12 percent for all reaches outside of 120 feet from Lake Washington. Stream A flows during heavy rain events, through a maintained lawn with no defined bed and bank, and likely spills over the existing bulkhead (within the property located at 4640 E Mercer Way). It is improbable to assert that fish would use this watercourse for any part of their life history requirements. There is no uppermost point of fish use based on simple, nontechnical observations. Stream A is correctly classified as a Type 3 Watercourse.

To further substantiate the non-fish determination, a slope analysis was performed using the King County DEM. This analysis indicates that stream gradient exceeds 20 percent for 92 linear feet in areas downstream of the subject property. See Figure 2 below.

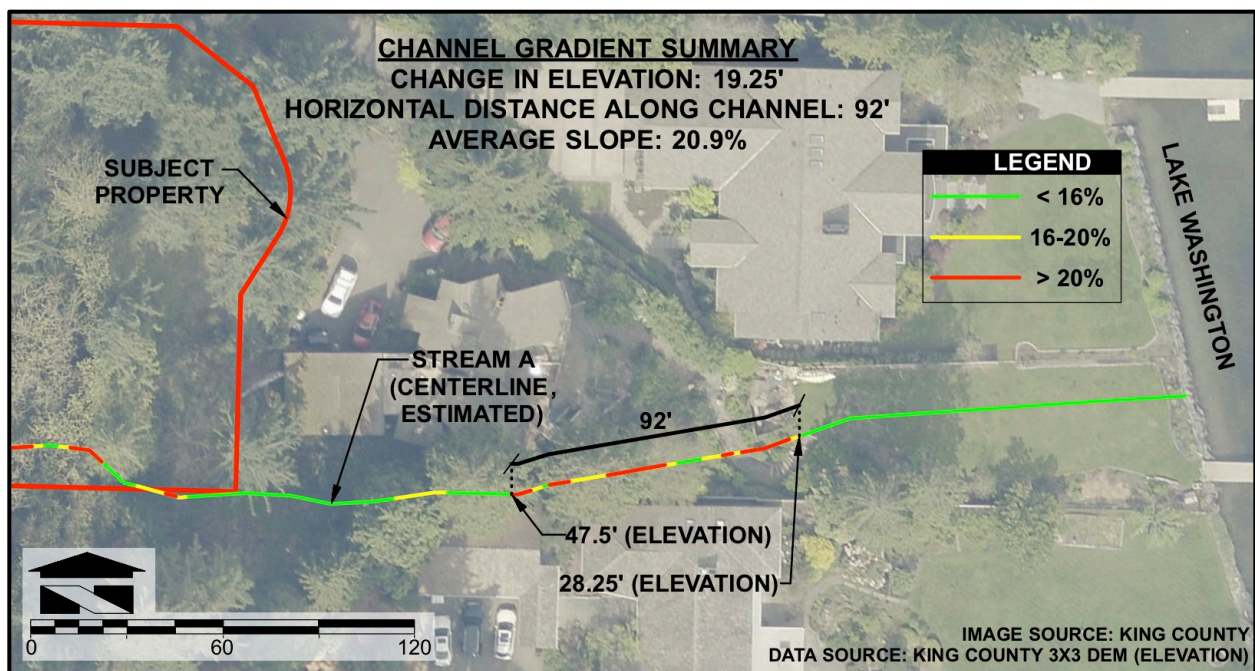

Figure 2: Potential Fish Use

5.0 USE OF THIS REPORT

This Critical Area Study is supplied to Four Seasons Homes, LLC as a means of determining critical area conditions, as required by the City of Mercer Island during the permitting process. This report is based largely on readily observable conditions and, to a lesser extent, on readily ascertainable conditions. No attempt has been made to determine hidden or concealed conditions.

The laws applicable to wetlands are subject to varying interpretations and may be changed at any time by the courts or legislative bodies. This report is intended to provide information deemed relevant in the applicant's attempt to comply with the laws now in effect.

The work for this report has conformed to the standard of care employed by wetland ecologists. No other representation or warranty is made concerning the work or this report and any implied representation or warranty is disclaimed.

Wetland Resources, Inc.

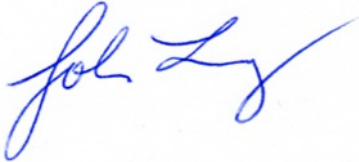

John Laufenberg
Principal Ecologist, PWS #1742

Wetland Resources, Inc.



Niels Pedersen
Senior Ecologist

6.0 REFERENCES

- Brinson, M.M. 1993. A Hydrogeomorphic Classification for Wetlands. Technical Report WRPDE-4. US Army Engineers Waterways Experiment Station, Vicksburg, MS.
- Cowardin, L.M., V. Carter, F.C. Golet and E.T. Laroe. 1979. Classification of Wetlands and Deep Water Habitats of the United States. U.S. Fish and Wildlife Service. FWS/OBS 79/31.
- Environmental Laboratory. 1987. Corps of Engineers Wetland Delineation Manual. Technical Report Y-87-1. Environmental Laboratory, Department of the Army, Corps Waterways Experiment Station, Vicksburg, MS.
- Hruby, T. 2014. Washington State Wetland Rating System for Western Washington: 2014 Update. Washington State Dept. of Ecology Publication No. 14-06-029. Olympia, WA.
- Lichvar, R.W, D.L. Banks, W.N. Kirchner, and N.C. Melvin. 2016. The National Wetland Plant List: 2016 wetland ratings. Phytoneuron 2016-30: 1–17. Published April 28, 2016. ISSN 2153 733X.
- Munsell Color. 2012. Munsell® Soil Color Book. Munsell Color, Grand Rapids, MI.
- NOAA National Weather Service Forecast Office, Seattle, Washington.
<<http://www.weather.gov/climate/index.php?wfo=sew>>.
- Olson, P. and E. Stockdale. 2010. Determining the Ordinary High Water Mark on Streams in Washington State. Second Review Draft. Washington State Department of Ecology, Shorelands and Environmental Assistance Program. Lacey, WA. Ecology Publication # 08-06-001.
- StreamNet. 2014. StreamNet Mapper. http://www.streamnet.org/mapping_apps.cfm. Accessed July 2018.
- U.S. Army Corps of Engineers (Corps). 2010. Regional Supplement to the Corps of Engineers Wetland Delineation Manual: Western Mountains, Valleys, and Coast Region (Version 2.0). U.S. Army Engineer Research and Development Center Environmental Laboratory. Vicksburg, MS. Publication # ERDC/EL TR-10-3.
- U.S. Fish and Wildlife Service. National Wetland Inventory (NWI). Wetlands Mapper. <http://www.fws.gov/wetlands/>. Accessed July 2018.
- Washington State Department of Fish and Wildlife (WDFW). 2011. SalmonScape. (<http://wdfw.wa.gov/mapping/salmonscape/index.html>). Accessed July 2018.
- Washington State Department of Fish and Wildlife (WDFW). 2013a. Threatened and Endangered Wildlife in Washington: 2012 Annual Report. Listing and Recovery Section, Wildlife Program, Washington Department of Fish and Wildlife, Olympia, WA. 251 pp.
- Washington State Department of Fish and Wildlife (WDFW). 2013b. Priority Habitats and Species: PHS on the Web. (<http://wdfw.wa.gov/mapping/phs/>). Accessed July 2018.

(this page intentionally left blank)

Appendix A

Critical Area Study Map
(Site Plan)

(this page intentionally left blank)

CRITICAL AREA STUDY MAP
FOUR SEASONS LLC - 4634 E MERCER WAY SFR

REVISION 1 SITE PLAN

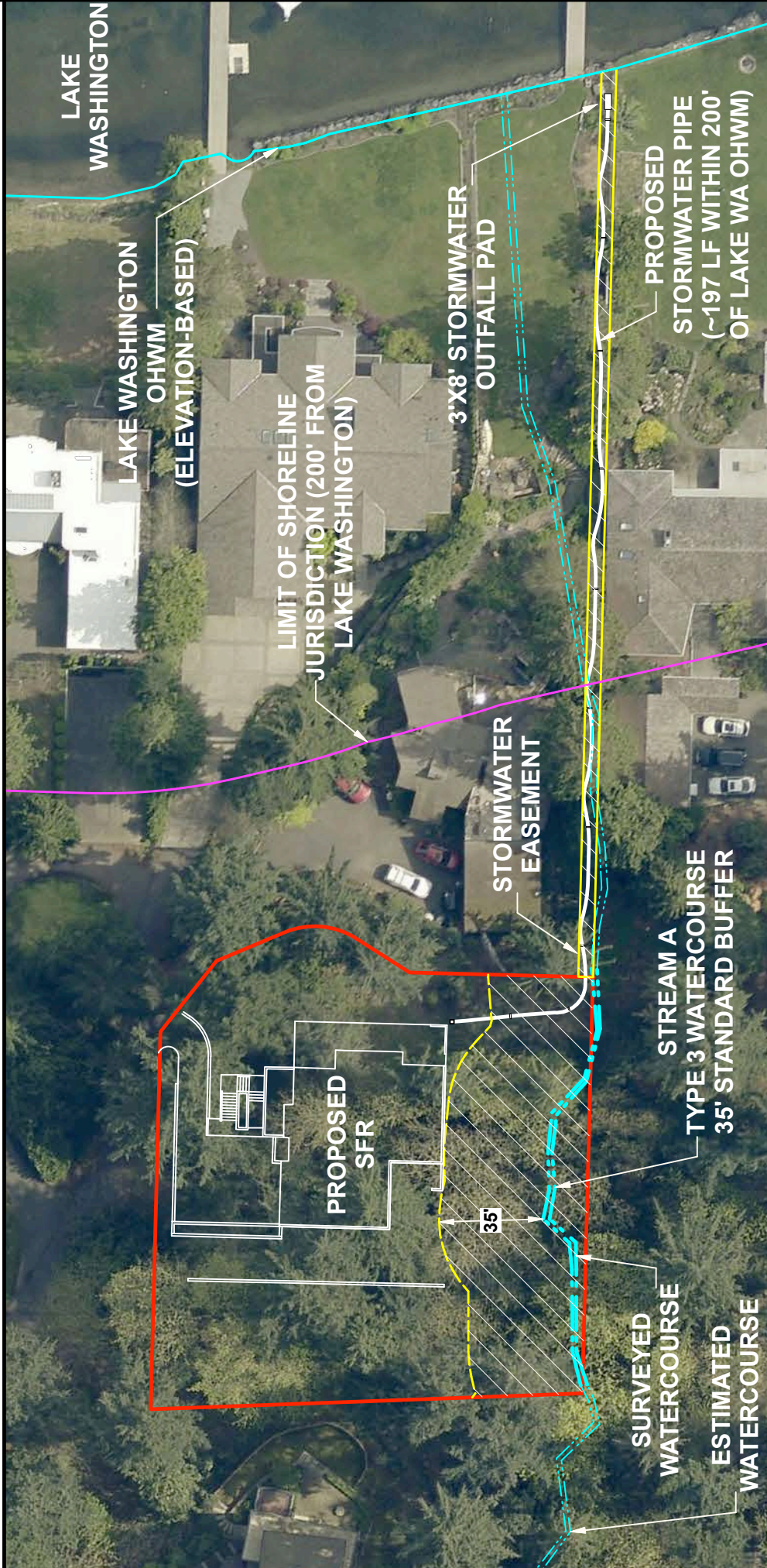

IMAGE SOURCE: KING COUNTY
 DATA SOURCES: APS SURVEY AND MAPPING
 (STREAM OHWM, PARCEL), STUDIO19
 ARCHITECTS (PROPOSED IMPROVEMENTS)



Scale 1" = 50'

| LEGEND | |
|--------|---------------------------------|
| | TYPE 3 WATERCOURSE (DELINEATED) |
| | TYPE 3 WATERCOURSE (ESTIMATED) |
| | WATERCOURSE BUFFER |
| | PROPERTY BOUNDARY |

Wetland Resources, Inc.
 DELINEATION / ALTIITUDE / RESTORATION / HABITAT CREATION / PERMIT ASSISTANCE
 9505 19th Avenue S.E. Suite 106 Everett, Washington 98208
 Phone: (425) 337-3174
 Fax: (425) 337-3045
 Email: mailbox@wetlandresources.com

Critical Area Study Map
Four Seasons LLC
4634 E Mercer Way SFR
 REVISION 1
 Four Season Homes, LLC
 Attn: Paul Maksimchuk
 11319 24th Street E
 Edgewood, WA 98372
 Sheet 1/1
 WRI Job #: 17067
 Drawn by: NP
 Date: 10/1/2018

(this page intentionally left blank)



memorandum

date February 21, 2019
to Robin Proebsting, Senior Planner
from Jessica Redman, Ecologist
subject Four Seasons Homes, LLC – 4634 East Mercer Way Critical Areas Review

Environmental Science Associates (ESA) has prepared this memorandum on the behalf of the City of Mercer Island (City). The purpose of this memo is to verify the accuracy of the critical areas study submitted with the development application for site at 4634 East Mercer Way and to confirm whether the proposed project complies with Mercer Island City Code (MICC) Chapter 19.07 – *Environment*.

The site is a currently undeveloped parcel located at 4634 East Mercer Way (King County Tax Parcel 755870-0008). The applicant proposes to construct a single-family residence on the site. The proposed development includes the installation of a pipe that would collect stormwater from the site and discharge it to an outfall pad approximately ten feet from the ordinary high water mark (OHWM) of Lake Washington. The pipe and outfall pad would be located within a stormwater easement. No grading, trenching, or vegetation removal will be required to install the stormwater pipe as it will be laid over the existing vegetation which is primarily invasive English ivy and mowed lawn.

At the request of the City, ESA reviewed the *Critical Area Study for Four Seasons Home, LLC – 4634 E Mercer Way SFR* (prepared by Wetland Resources, Inc. [WRI] and dated October 1, 2018) and the *4634 East Mercer Way Residence Site Plan* (prepared by Litchfield Engineering and dated June 14, 2016). Our scope of work included review of regulations for wetlands, streams and their buffers; ESA did not review steep slopes or geological hazard regulations. ESA also conducted a site visit on February 19, 2019, meeting onsite with the applicant and City senior planner Robin Proebsting.

Report Summary

According to the *Critical Area Study for Four Seasons Home, LLC – 4634 E Mercer Way SFR* (hereinafter referred to as the WRI Report) two regulated features occur within the project area: Lake Washington and a City-mapped Type 3 stream (Stream A). An additional stream is mapped by the City as occurring north of the property; however, according to the WRI Report, this stream was not located in the field and is likely the result of a mapping error.

A portion of the stormwater easement is located within 200 feet of the OHWM of Lake Washington and therefore is within shoreline jurisdiction. Construction of the single family home is proposed to fully occur outside of the shoreline jurisdiction. The shoreline designation for the project site is Urban Residential. According to MICC 19.07.110(D) Table A, single family dwellings, including accessory uses and structures are considered categorically exempt in Urban Residential shorelines. According to the WRI Report, the stormwater pipe is an accessory use of the proposed single family residence and is therefore, covered under this exemption.

Additionally, per MICC 19.070.070(B), Type 3 watercourses are required a 35-foot standard buffer. Outside of the installation of the stormwater pipe, no development is proposed within the 35-foot stream buffer. According to MICC 19.07.030, new utility facilities are allowed in critical area buffers, if they meet the following standards:

- a. Construction is consistent with best management practices;
- b. The facility is designed and located to mitigate impacts to critical areas consistent with best available science;
- c. Impacts to critical areas are mitigated to the greatest extent reasonably feasible so there is no net loss in critical area functions;
- d. Utilities shall be contained within the footprint of an existing street, driveway, paved area, or utility crossing where possible; and
- e. The code official may require a critical areas study or restoration plan for this allowed alteration.

According to WRI, metal collars will be installed by hand that will anchor the pipe to the ground surface in several locations. The pipe will be elevated over the crossing of Stream A to avoid any alterations to stream flow. Installation of the pipe will occur within the existing utility easement and in areas where nonnative vegetation, primarily English ivy, is dominant. Installation of the rock splash pad will occur in an area that is currently mowed lawn. Best management practices (BMPs) will be proposed during construction as part of the temporary erosion and sediment control (TESC) plan.

Because the installation of the stormwater facilities will not require any grading, trenching, or vegetation removal; will occur in areas that are currently dominated by invasive vegetation or mowed lawns; and because impacts to critical areas and their buffers have been avoided, WRI concludes that the above requirements for the allowance of new utilities in critical area buffers have been met. As a result, no mitigation is proposed.

According to the *4634 East Mercer Way Residence Site Plan* (hereinafter referred to as the Plan Sheets), sheets 1/6 through 3/6 show both a 25-foot and 35-foot stream buffer. According to MICC 19.97.070.B, the standard 35-foot buffer of a Type 3 stream, may be reduced to 25 feet if the area of buffer reduction is enhanced. Neither the WRI Report or the Site Plans mention buffer reduction or propose enhancement.

Review and Site Findings

During the February 19, 2019 site visit, ESA located Stream A in the southern extent of the project parcel and along the low point of a shallow ravine. No flow was present during the site visit and sections of the channel were largely vegetated. The channel exhibited very shallow banks. Downstream of the parcel, some gravel deposition and braided scour marks were observed. Ordinary high water mark flagging from a previous delineation was observed within the parcel and showed a channel width of approximately 6- to 12-inches throughout most of the parcel. Based on conditions observed during the February 19, 2019 site visit, ESA agrees that Stream A is an

intermittent stream that does not support fish and therefore, is correctly categorized as a Type 3 stream with a 35-foot buffer. No other streams or wetlands were observed at the site during the site visit. ESA agrees that the City-mapped stream occurring north of the parcel is likely the result of a mapping error.

During the February 19, 2019 site visit, ESA walked the alignment of the onsite portion of the proposed stormwater pipe. Though under a native forested canopy of Douglas fir, other vegetative strata at the site are dominated by nonnative species, including English ivy, Himalayan blackberry, and cherry laurel. The offsite portion of the utility easement was observed from the project parcel and contained a mixture of bare ground, landscaped plants, and mowed lawn.

In discussions with the applicant during the February 19, 2019 site visit, it was explained that the stormwater pipe will not be installed along the ground surface as represented in the WRI Report, but instead will be elevated throughout its length. Collars will be installed by hand along the length of the pipe to hold the pipe up off the ground instead of anchoring the pipe to the ground. As mentioned above, the pipe will be elevated throughout its length and not just at the crossing of Stream A. It is unclear whether this discrepancy is an error in reporting or if the design has changed since the report was written. Additionally, no details of pipe installation were included in the plan sheets.

Conclusions and Recommendations

Based on the review of the documents and MICC, as well as the site visit, ESA concludes the following:

- ESA agrees with the WRI Report that proposed installation of the stormwater pipe and gravel splash pad within shoreline jurisdiction is exempt from shoreline substantial development requirements as an appurtenance to the development of a single family residence development. According to MICC 19.16.010, an appurtenance “is a structure which is necessarily connected to the use and enjoyment of a single family dwelling.” An example of which is utilities.
- ESA agrees that the proposed installation of the stormwater pipe within the buffer of Stream A is an allowed use per MICC 19.07.030. The project met all requirements of the critical areas buffer allowance by proposing the following: 1) BMPs will be implemented during construction as part of the TESC plan; 2) impacts have been avoided and minimized to the extent possible and in agreement with best available science; 3) the project will result in a no net loss of critical area functions; 4) the stormwater pipe will be installed in an existing utility easement; and 5) a critical area study has been conducted.
- ESA believes that the aboveground installation of the stormwater pipe has avoided impacts to the critical areas buffer on and off site. Installation will be performed by hand and will not require any grading, trenching, or vegetation removal. Minimal impacts to vegetation during pipe collar installation may occur; however, ESA agrees that these impacts will be inconsequential to current buffer ecological functions. The area of the proposed stormwater pipe installation is currently dominated by invasive species, mowed lawn, and bare ground. No loss of ecological function is anticipated pre- and post-construction and therefore, ESA agrees that no mitigation for the stormwater pipe is necessary.
- ESA recommends that WRI revise the WRI Report or provide a brief memo reflecting the revised stormwater pipe installation method.

- Both a 25-foot and a 35-foot buffer are displayed on pages 1/6 through 3/6 of the Plan Sheets. If the 25-foot buffer is correct, buffer enhancement would be required under MICC 19.07.070.B, and the WRI Report and Plan Sheets would need to reflect the buffer reduction and subsequent buffer enhancement. If the 35-foot buffer is correct, though no permanent buffer impacts are proposed, it is likely that temporary impacts to the buffer would occur during construction. Clearing limits were not included on the Plan Sheets, however, due to the proximity of the residence to the edge of the buffer, temporary construction impacts are anticipated. If temporary impacts to the buffer are anticipated, the impacted portion of the buffer should be revegetated post-construction with native vegetation, to ensure a no net loss of ecological function. Additionally, the WRI Report and Plan Sheets should be revised to include a buffer restoration plan.
- In conclusion, ESA believes that if the above recommendations are taken to clarify the pipe installation methods, the correct buffer width, and the restoration or enhancement of the buffer post-construction as needed, the proposed development will not have an impact on critical areas (wetlands and streams) or their buffer and complies with MICC Chapter 19.07 – *Environment*.



DETERMINATION OF NON-SIGNIFICANCE (DNS)

Application Nos.: **SEP18-021 (CAO17-007)**

Description of proposal: **Request for approval of a critical areas determination in order to modify a steep slope and installed a stormwater drainage associated with construction of a new single-family residence.**

Proponent: **Paul Maksimchuk / Four Season Homes LLC**

Location of proposal: **4634 E Mercer Way, Mercer Island, WA, 98040;
Identified by King County Assessor tax parcel number: 755870008**

Lead agency: **City of Mercer Island**

Project Documents: **Please follow this file path to access the associated documents for this project: <https://mieplan.mercergov.org/public/CAO17-007/>**

Possible critical area impacts are addressed by Mercer Island City Code Chapter 19.07. Based on review of the proposal and applicable City code sections, the lead agency for this proposal has determined that the proposal does not have a probable significant adverse impact on the environment that is not addressed by the aforementioned code sections. An environmental impact statement (EIS) is not required under RCW 43.21C.030(2)(c). This decision was made after review of a completed environmental checklist. This information is available to the public on request.

_____ There is no comment period for this DNS.

✓ _____ This DNS is issued after using the optional DNS process in WAC 197-11-355. There is no further comment period on the DNS.

_____ This DNS is issued under WAC 197-11-340(2); the lead agency will not act on this proposal for 14 days from the date below. Comments must be submitted by N/A at 5:00 pm.

Responsible Official: **Robin Proebsting, Senior Planner
City of Mercer Island
9611 SE 36th Street
Mercer Island, WA 98040
Phone: (206) 275-7717
Email: robin.proebsting@mercergov.org**

Date: February 25, 2019

Signature: 

APPEAL INFORMATION

This decision to issue a Determination of Non-significance (DNS) rather than to require an EIS may be appealed pursuant to Section 19.07 of the Mercer Island Unified Land Development Code, Environmental procedures.

- ✓ _____ Any party of record may appeal this determination to the City Clerk at 9611 SE 36th Street Mercer Island, WA 98040 no later than **5:00 PM on March 11, 2019** by filing a timely and complete appeal application and paying the appeal fee. You should be prepared to make specific factual objections. Contact the City Clerk to read or ask about the procedures for SEPA appeals. To reverse, modify or remand this decision, the appeal hearing body must find that there has been substantial error, the proceedings were materially affected by irregularities in procedure, the decision was unsupported by material and substantial evidence in view of the entire record, or the decision is in conflict with the city's applicable decision criteria.

_____ There is no agency appeal.

_____ Any person aggrieved by the issuance of this decision may seek review from the Shorelines Hearings Board by filing a petition for review within twenty-one days of the date of filing of the decision (**by January 23, 2018**) as defined in RCW 90.58.140(6). Within seven days of the filing of any petition for review with the Board, the petitioner shall serve copies of the petition on the Washington State Department of Ecology, the Office of the Attorney General, and the City of Mercer Island.

More information on this process can be found on the Shoreline Hearing Board's website: http://www.eho.wa.gov/Boards_SHB.aspx or by calling (360)664-9160.

Joanne Thomas Blackburn
Direct: (206) 676-7540
E-mail: jblackburn@gth-law.com

October 11, 2017

VIA EMAIL AND REGULAR MAIL

Robin Proebsting, Senior Planner
Development Services Group
City of Mercer Island
9611 SE 36th Street
Mercer Island, WA 98040
Email: robin.proebsting@mercergov.org

RE: Comments Upon Request for Approval of A Critical Area Determination In Order to Modify A Steep Slope, Associated with Construction of a New Single Family Residence

Applicant/Owner: Paul Maksimchuk/Four Seasons Homes LLC
Location of Property: 4634 E. Mercer Way, Mercer Island, WA 98040
King County Tax Parcel: 75587008
Building Permit #: 1507-166REV

Dear Ms. Proebsting:

I write to join in my neighbor's letter to you, Mr. Bruce Edwards, about our mutual driveway that will be affected by the proposed work. My family lives at 4556 East Mercer Way, one home up from Bruce. I am writing you to provide my comments relative to the pending application by Paul Maksimchuk/Four Seasons Homes LLC ("Applicants") to receive a favorable Critical Area Determination that will permit modification of a steep slope. The subject property (4634 East Mercer Way) as well as the surrounding area and roadway access all lie in a "geologic hazard area" within the meaning Mercer Island City Code ("MICC") 19.07060.A.

The views in my letter are solely my own and do not state the views or legal position of anyone else. Further, although I am a practicing attorney duly licensed in the State of Washington, I am not providing legal representation to anyone else in this matter. I am not opposed to development of this property, or others, and a large part of my legal practice is construction litigation wherein I have represented developers, general contractors, construction companies, subcontractors and material suppliers. However, I have a concern for this property and the wear and tear on our mutual driveway.

Reply to:
Seattle Office
600 University, Suite 2100 (206) 676-7500
Seattle, WA 98101 (206) 676-7575 (fax)

Tacoma Office
1201 Pacific Ave., Suite 2100 (253) 620-6500
Tacoma, WA 98402 (253) 620-6565 (fax)

I join in Bruce's letter, his objections and proposals. I have not discussed this in great detail with my other neighbors, but want to voice my concern for the shared roadway to all of our homes. It is the only access my family and I have to our home. Should something happen to it, we will be in a difficult position. Our cars are kept in our garage at our home each night at the bottom of the roadway. We depend on our cars to get to and from our offices in Seattle. If something were to happen to the driveway, it would not only affect our work, but potentially even more. If some medical emergency were to arise, we would have no access to get help quickly or easily. Moreover, the fire hydrant for our neighborhood is located on the very access road that is at issue.

My concern is that experts hired by others have already identified that our mutual driveway cannot hold the type of traffic that is proposed for use to develop this lot. Please see the exhibits attached to Bruce's letter, especially Exhibit F, the Landau report dated October 2, 2015, page 2, Existing Access Road. Specifically the opinion that "It is likely that the existing access road will fail, necessitating total replacement."

In the event that the City decides to approve the Applicants' request for a Critical Area Determination that will permit modification of the steep slope at the subject property, I join in the requests made by Bruce that the City impose various conditions pursuant to MICC 19.07.060 upon that approval as listed in his letter. The access road will not be able to handle the proposed weight and traffic that is projected for this development.

Thank you for taking time to consider our neighborhood's concerns.

Very truly yours,



Joanne Thomas Blackburn

JTB:ck

Reference File No.: CA017-007
Building Permit No.: 1507-166REV

RECEIVED
SEP 20 2017
CITY OF MERCER ISLAND
DEVELOPMENT SERVICE GROUP

September 20, 2017

My wife and I are residents of 4632 East Mercer Way. We are immediately downhill from the proposed project and will be maximally impacted by the new construction.

In August of 2015, I submitted a letter listing my concerns to Reference File No.: SEP15-017 that you should have on record. I am attaching a copy of it along with this response, as the four items listed there are just as valid today as they were then.

I remain most concerned that the drainage issue be properly addressed, as our residence is in such a vulnerable position. The storm drains that protect our residence from existing street run-off have proven adequate, but I have no confidence that they can handle much more volume than at present. Any breach of the existing system will result in flooding of our residential structure.

The blockage of our driveway during construction must be managed. Construction related vehicles must not be allowed to block ingress/egress for a prolonged period.

Sincerely
Tom Davidson
206232-6813

enclosure

Reference File No: SEP15-017
Building Permit No: 1507-166

August 23, 2015

My name is Tom Davidson and my wife and I reside at 4632 East Mercer Way. I am responding to the Notice of Application posted on the tax parcel no 755870-0008.

Our residence is downhill from the proposed project at the end of the shared access driveway. I am very concerned about the environmental impact on our property, primarily for the following reasons:

1. The large scale stripping of the parcel will most certainly result in water runoff issues that must be controlled. In my case, any additional water and debris that is allowed to enter into the existing access roadway to my property will pose an immediate danger to my residence in the form of flooding into the structure. Our home was constructed in 2008, and at that time careful and extensive storm water mitigation was implemented to accommodate the existing water hazard by placing two catch drains which divert runoff away from our residence and direct it into Lake Washington. The effectiveness of this system is dependent upon keeping the drains clear of debris and keeping volumes of runoff substantially the same as at present.
2. The removal of 500+ yards of excavation material will strain the capacity of the private driveway serving the property and some 14 other residences. The multiple transits of this fragile roadway with heavy loads of soil will likely advance deterioration of the surface as well as the potential for other damage to the right of way.
3. The private roadway serves as access to 14 residences and contains two blind corners. It is primarily one way and rarely free of activity. The systematic use of the roadway for excavation removal will place an inordinate traffic demand on it. Consideration must be given to the delays caused by this use and temporary stoppage of traffic must be controlled.
4. The common use roadway serving the property and affected by items 2 and 3 above will be of concern to all property owners who use it. They should all be contacted, and given the opportunity to respond to this notice, either by direct mail or by posting a notice visible to all.

Sincerely
Tom Davidson
Home 206 232-6813
Cell 206 498-0917

COMMENTS
OF
BRUCE N. EDWARDS

*Concerning Request For Approval of Critical
Area Determination to Modify A Steep Slope*

Submitted October 10, 2017

Deadline

for Comments: October 11, 2017

DSG File #: CA017-007

Applicant/Owner: Paul Maksimchuk/Four Seasons
Homes LLC

Location of Property: 4634 E. Mercer Way, Mercer
Island, WA 98040

King County

Tax Parcel: 75587008

Building Permit #: 1507-166REV

LAW OFFICES OF
SORENSEN & EDWARDS, P.S.

701 FIFTH AVENUE, SUITE 3300
SEATTLE, WASHINGTON 98104

RECEIVED

OCT 10 2017

Michael R. Sorensen
Member, Washington Bar
DIRECT LINE (206)-224-8224

FACSIMILE (206) 682-7100

BRUCE N. EDWARDS
Member, Washington Bar
DIRECT LINE (206)-224-8225

October 10, 2017

VIA HAND DELIVERY

Robin Proebsting, Senior Planner
Development Services Group
City of Mercer Island
9611 SE 36th Street
Mercer Island, WA 98040

Re: Comments Upon Request for Approval of A Critical Area Determination In Order to Modify A Steep Slope, Associated with Construction of a New Single Family Residence

DSG File #: CA017-007
Applicant/Owner: Paul Maksimchuk/Four Seasons Homes LLC
Location of Property: 4634 E. Mercer Way, Mercer Island, WA 98040
King County Tax Parcel: 75587008
Building Permit #: 1507-166REV

Dear Senior Planner Proebsting:

I am writing you to provide my comments relative to the pending application by Paul Maksimchuk/Four Seasons Homes LLC ("Applicants") to receive a favorable Critical Area Determination that will permit modification of a steep slope. The subject property (4634 East Mercer Way) as well as the surrounding area and roadway access all lie in a "geologic hazard area" within the meaning Mercer Island City Code ("MICC") 19.07060.A.

Procedural

I begin by noting that the "Public Notice of Application" that was posted adjacent to East Mercer Way at the 4600 block road sign indicates that copies of the Project Documents may be obtained at <https://mieplan.mercergov.org/public/CA017-007/>. However, this website link is non functional, and has been for a period of time, with the result that the notice requirements of MICC 19.15.020.D.2.k ("A link to a website where additional information about the project can be found") has not been met. This requirement is mandatory. The failure to meet the public notice requirements means that the requested Critical Area Determination cannot be made at this time. I therefore request that the City of Mercer Island ("City) renounce the Critical Area Determination in a manner that complies with all applicable requirements, including those of MICC 19.15.020.D.2.k.

Relation of My Comments to the Comments of My Other Neighbors

I understand that certain of my neighbors have made their own comments requesting that the City disapprove the Applicants' request for a Critical Area Determination that will permit modification of the steep slope at the subject property. I hereby join my neighbors' comments and similarly ask that the City disapprove the Applicants' request for a Critical Area Determination that will permit modification of the steep slope at the subject property.

In the event that the City is nonetheless inclined to approve the Applicants' request for a Critical Area Determination that will permit modification of the steep slope at the subject property, I ask in the alternative that the City impose various conditions pursuant to MICC 19.07.060 upon that approval.

The views in my letter are solely my own and do not state the views or legal position of anyone else. Further, although I am a practicing attorney duly licensed in the State of Washington, I am not providing legal representation to anyone else in this matter. For perspective, I am not opposed generally to development, and have during the course of my legal practices, represented developers and construction companies. I do believe that development and construction activity must occur in a responsible manner.

Exhibits

The following Exhibits are attached to this letter and are incorporated herein by this reference:

- Exhibit A Photograph from East Mercer Way looking eastward towards "T," showing extreme slope of land on north side of Access Roadway
- Exhibit B Photograph Taken Looking From Bottom of Gully Showing Portion of Access Roadway Between "T" and East Mercer Way Looking Up To Roadway, Eastern End
- Exhibit C Photograph Taken Looking From Bottom of Gully Showing Portion of Access Roadway Between "T" and East Mercer Way Looking Up To Roadway, Western Access End
- Exhibit D Photograph Taken At Western End of Access Roadway Between "T" and East Mercer Way, showing proximity of cracks to north side of roadway and gully
- Exhibit E Photograph showing detail of cracks in Exhibit D

- Exhibit F Photograph Taken At Eastern End of Access Roadway Between “T” and East Mercer Way, showing proximity of cracks to north side of roadway and gully
- Exhibit G Photograph showing detail of cracks at eastern end of Access Roadway Between “T” and East Mercer Way, just before the “T”
- Exhibit H Showalter Expert Report (February 7, 2017) concerning Access Road, including photographs
- Exhibit I Heavey Expert Report (February 3, 2017) concerning Access Road, including photographs
- Exhibit J Rohrbach Expert Report (February 7, 2017) concerning legal requirement in a Critical Area Determination to address impact impact on other critical areas.
- Exhibit K Heavey Expert Report (October 2, 2015) concerning Access Road
- Exhibit L Conditions of Permit Approval, Permit 1507-166, as issued to Barcelo Homes, Inc. August 23, 2016
- Exhibit M Order of Dismissal on Summary Judgment, King County Cause # 15-2-26847-3 SEA

Commenter’s Personal Familiarity With The Neighborhood

My family and I reside at 4560 East Mercer Way; I have owned this single family home since 1990. For reference purposes, my property lies approximately 750 feet or so as the crow flies north of 4634 East Mercer Way (the primary property subject to the Critical Area Determination). I make all of the statements in this letter based upon my personal knowledge, except where I indicate otherwise (such as where I cite certain expert reports that are an attachment to this letter).

Description of the Neighborhood And the Access Roadway

I am thoroughly familiar with our neighborhood, including the narrow access roadway that all of us who reside within the neighborhood must share and rely upon as our sole means of ingress and egress. When I say “narrow” I mean narrow: the roadway is less than 15 feet wide and as narrow as 9 feet in some spots. Exhibit K, page 2. Like my neighbors, my legal rights to use this narrow access roadway for ingress and egress to my property ultimately derive from that certain deed granted by Burwell & Morford, a Washington corporation, to Ray U. Muffley, recorded under King County Auditor’s Number 3004748 on July 20, 1938. However, this roadway is a “public access roadway” in the sense that there is no gate at East Mercer Way, or

anywhere else for that matter, and there are no signs forbidding the public to access the roadway. Thus, members of the public (as well as those of us who reside within the neighborhood) are able to access this roadway as is desired.

This road accesses East Mercer Way at the City's 4600 block street sign on East Mercer, and then proceeds east approximately 300 feet, where the road "forks" at a T intersection. Exhibit A. Exiting the "T" to the right, the roadway accesses 4634 East Mercer Way through a series of sharp turns; exiting the "T" to the left, the roadway accesses my property at 4560 East Mercer through one long sweeping steep curve. Exhibit A. All of us who reside in the neighborhood as well as those who come into our neighborhood MUST progress through the "T" and through the 300 feet of roadway between the "T" and East Mercer Way if we are to reach East Mercer Way. There is simply no other way.

The crux of the problem that I like my neighbors face is that should either the "T" or the 300 feet of narrow roadway become impassable for any reason, including delays due to construction equipment blocking the access roadway, we are trapped. While the estimates on the precise number of trips up and down the access roadway as a part of the grading and construction activity at 4634 East Mercer Way vary, it seems reasonably certain that there will be several hundred trips over the access road with heavy construction equipment, including dump trucks, excavation equipment, and logging trucks. Exhibit H, pages 2 -3; Exhibit I, pages 2 -3; When I say the roadway is "narrow" I mean narrow: the 300 feet of roadway from the "T" to East Mercer Way is less than 15 feet wide in most spots, with a six foot high rock wall on one side and a steep gully approximately 60 feet deep on the other. See Exhibits B and C. There is no room for error in navigating this portion of the road, particularly during the wet season or the winter, when the road can become slippery. Moreover, and this is probably even more significant, the roadway is asphalt surface, not concrete, and was built years ago for light passenger vehicle use, not heavy commercial use. The roadway is built on graded native materials, not crush rock, and there are no supporting retaining walls. Exhibit K, pages 2 – 3. In two places within the 300 feet of roadway between the "T" and East Mercer Way, two major cracks have opened in the asphalt surface where the subgrade has slumped into the adjacent gully. Each of these major cracks is approximately thirty feet long, and at the widest, approximately 3/8" wide. One of these major cracks is about twenty-five feet east of East Mercer Way and at this spot the adjacent gully is at its deepest – approximately 60 feet. Exhibits D – G.

The gully that is adjacent to the 300 feet of roadway between the "T" and East Mercer Way is heavily eroded and drains directly into Lake Washington. It is a steep slope. See Exhibits B and C.

Should the portion of the roadway that lies between the "T" and East Mercer Way fail, or should a piece of construction equipment leave this portion of the roadway for any reason, the result would likely be catastrophic. Not only would all of us in the neighborhood be trapped, but

also, the possibility exists that fuel, hydrocarbons and other petrochemicals would leak or otherwise be spilled. There is no serious argument that rugged terrain with a significant difference in elevation between the access roadway and the bottom of the gully is involved, see Exhibits B and C. In the event a construction vehicle should leave the access roadway for any reason, it will roll over into this gully which would likely threaten the integrity of a vehicle's fuel tanks.

The difficulties that will attend removal of a large piece of construction equipment from the gully given the numerous trees in and around the gully pose obvious problems, as well as the slope itself. This alone could tie up the public access roadway as well as East Mercer Way for a considerable period of times, perhaps days.

An even greater problem will be the difficulties of getting containment systems immediately in place, and one must anticipate that some fuel, hydrocarbons and other petrochemicals would reach Lake Washington. The immediate portion of Lake Washington into which the gulley drains is within an area identified by the Washington State Department of Fish and Wildlife as a salmon spawning area in which no work in water is to occur (because of salmon spawning) between October and July. A significant spill of fuel, hydrocarbons and other petrochemicals that reaches Lake Washington would endanger this critical salmon habit, perhaps for years.

Given all of this, it is not surprising that the City of Mercer Island has previously determined that the area in which the roadway lies is itself a Critical Area (because it is a geologic hazard area) and thus, deserving of protection and special consideration. MICC 19.07.060.D.1. ("Alterations of geologic hazard areas may occur if the code official concludes that such alterations * * * [w]ill not adversely impact other critical areas"). See also Exhibit J, page 4. Absolutely no evidence has been submitted by Applicant that its activities upon the access roadway will not impact the roadway itself or any other portion of the geologic hazard area within which the roadway lies.

What Does All This In The Context Of The Present Request For Approval Of A Critical Area Determination In Order To Modify A Steep Slope At 4634 East Mercer Way?

First, and to repeat, I join the comments of my neighbors that the City disapprove the request for a Critical Area Determination to Modify a Steep Slope. This is the very best way to protect our roadway and the access it provides. Judge Andrus' decision in DuBrowa v. City of Mercer Island, et al., King County Cause No. 15-2-26847-3 SEA makes clear that the Critical Area determination is an open one, and one with which the City must deal because no final decision has yet been rendered by the City in accordance with the City's own ordinances (e.g., MICC 19.07.060). Exhibit M, page 9.

Second, and in the alternative, if the City does decide to approve the present Request for Approval of A Critical Area Determination In Order to Modify A Steep Slope at 4634 East Mercer Way, I believe that the City must attach conditions pursuant to MICC 19.07.060 to any Critical Slope Determination (that the steep slope at 4634 East Mercer can be modified) to protect those of us that rely daily upon our narrow roadway for ingress and egress, the Critical Area/geologically hazardous area in which our roadway lies, and the adjacent salmon spawning area of Lake Washington into which the gully that runs adjacent to the roadway drains. The conditions that I request be imposed in any Approval of a Critical Area Determination that permits modification of a Steep Slope at 4634 East Mercer Way are as follows:

- (a) That Barcelo Homes, Inc./Paul Maksimchuk/Four Seasons Homes LLC immediately post a \$50,000 cash bond in favor of those who reside in our neighborhood to provide full recompense for any damage to the roadway, its subroadway, adjacent landscaping, structures and rockeries, and/or adjacent slopes and waterways caused by the construction activity at 4634 East Mercer Way or for any economic loss suffered by any of such residents due to a denial of ingress and egress due to the construction activity at 4634 East Mercer Way protections. The \$50,000 cash bond shall be held at a commercial bank acceptable to the neighborhood residents and shall contain commercial reasonable terms for presentment of claims. Claims against the bond shall be presented to the commercial bank, with a copy to Barcelo Homes, Inc./Paul Maksimchuk/Four Seasons Homes LLC. Such claims shall be paid unless within thirty days after presentment, Barcelo Homes, Inc./Paul Maksimchuk/Four Seasons Homes LLC shall make written objection to the claim, at which point the commercial bank shall interplead the amount of the claim (or the amount of the bond, whichever is less) into the King County Superior Court. No grading or construction activity may begin at 4634 East Mercer Way until the cash bond is posted. The cash bond shall be returned to Barcelo Homes, Inc./Paul Maksimchuk/Four Seasons Homes LLC, as the case may be, 180 days after a final occupancy permit is issued for the residence to be constructed at 4634 East Mercer Way, so long as no claim has been against such bond has been presented to the commercial bank within such time period. This bond is intended to supplement and is in addition to the duty to fully repair and restore set forth in (d) below and to provide a source of funds to the extent that Barcelo Homes, Inc./Paul Maksimchuk/Four Seasons Homes LLC shall fail in such duty. At a bottom line, absent a \$50,000 cash bond, none of us have any real assurance that Barcelo Homes, Inc./Paul Maksimchuk/Four Seasons Homes LLC will have the funds to cover their obligations.

- (b) That Barcelo Homes, Inc./Paul Maksimchuk/Four Seasons Homes LLC be forbidden from parking any construction vehicles at any time at the "T" intersection or alongside East Mercer Way at any location.
- (c) That Barcelo Homes, Inc./Paul Maksimchuk/Four Seasons Homes LLC shall provide at least 72 hours advance notice to all neighborhood residents of any construction activity that is expected to close or block any portion of the roadway for more than a one-hour duration.
- (d) That Barcelo Homes, Inc./Paul Maksimchuk/Four Seasons Homes LLC are obligated to fully repair or restore any portion of the roadway, its subroadway, adjacent landscaping, structures and rockeries, and/or adjacent slopes and waterways caused by the construction activity at 4634 East Mercer Way. This requirement shall be in addition to and shall supplement the condition imposed by item 2 of "Construction Parameters," which says "[a]ll public access roadways are to be restored to the existing condition prior to project (pictures before start of work recommended). All access roads are to remain clean." Exhibit L, page 2.
- (e) That Barcelo Homes, Inc./Paul Maksimchuk/Four Seasons Homes LLC be forbidden to utilize full size dump trucks, full size logging trucks, and full size excavators and loaders, and instead that Barcelo Homes, Inc./Paul Maksimchuk/Four Seasons Homes LLC be required to utilize smaller size construction equipment and dump trucks to minimize the weight of vehicles and equipment that utilize the roadway.
- (f) That before construction or grading activity may begin at 4634 East Mercer Way, that Barcelo Homes, Inc./Paul Maksimchuk/Four Seasons Homes LLC be required to develop a spill containment and response plan by which Barcelo Homes, Inc./Paul Maksimchuk/Four Seasons Homes LLC set forth the manner in which they will respond should a spill of fuel, hydrocarbons and other petrochemicals in conjunction with construction activity at 4634 East Mercer Way, including during use of any portion of the roadway. The spill containment plan shall specifically list the equipment and materials that will be maintained onsite at 4634 East Mercer Way to contain any such spill. The draft of the spill containment plan shall be filed with the City with a copy provided to all neighborhood residents for comments. A thirty day comment period shall be provided, after which the City may finalize the spill containment and response plan. Once approved by the City, it shall be a condition of the building permit and the Critical Area Determination that Barcelo Homes, Inc./Paul Maksimchuk/Four Seasons Homes LLC abide in all

Robin Proebsting, Senior Planner
Development Services Group
City of Mercer Island
October 10, 2017
Page 8

material respects with such spill containment and response plan, and that failure to do so may result in a stop work order.

Conclusion

I respectfully request that the City proceed as set forth above. I hereby request a copy of the City's decision relative to Applicant's request for a Critical Area Determination that permits modification of a steep slope. Also, to the extent that the City decides to receive testimony upon Applicant's request, I hereby ask for an opportunity to testify in person. Finally, to the extent that the City desires additional materials beyond those I have submitted, please let me know so I can provide them.

Sincerely,

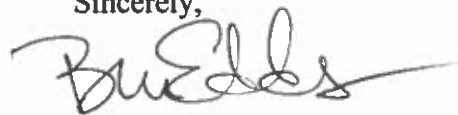
A handwritten signature in black ink, appearing to read "Bruce N. Edwards", with a long horizontal flourish extending to the right.

Bruce N. Edwards



Exhibit 14

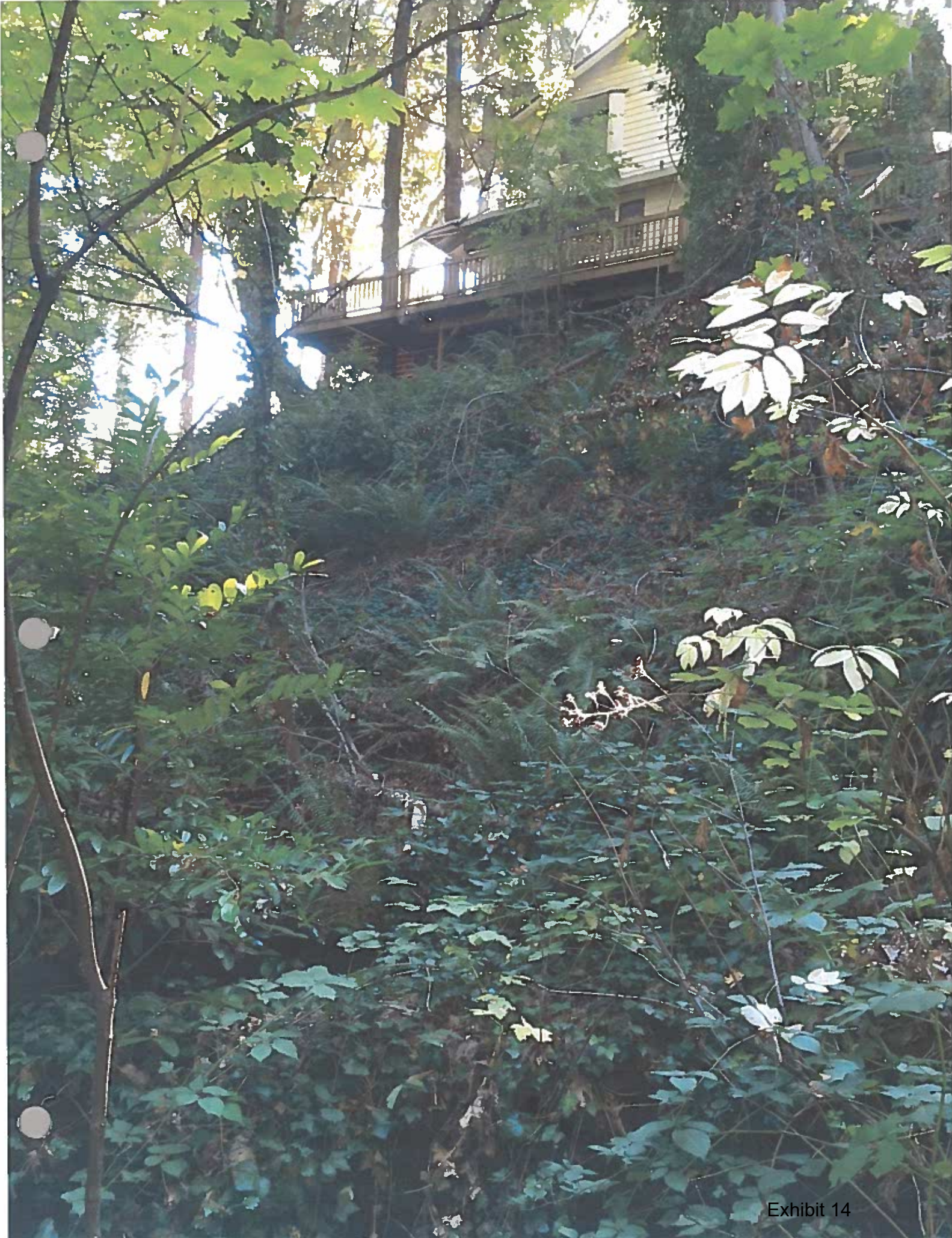

Exhibit 14



Exhibit 14



Exhibit 14









CONSTRUCTION DISPUTE RESOLUTION INC.®

February 7, 2017

Stoel Rives LLP
600 University Street, Suite 3600
Seattle, Washington 98101

via email to: rita.latsinova@stoel.com

Attn: Rita V. Latsinova

**Re: February Planning Commission
Four Seasons Homes L.L.C. Single Family Residence Development
4634 East Mercer Way
Mercer Island, Washington**

1. The asphalt access road from East Mercer Way to the subject lot is located in a critical area. It is very narrow in places and already appears to show signs of degradation at the edges. Too, besides being very steep in places it also contains numerous turns. One neighbor commented that dump trucks and even UPS trucks oftentimes have to do three and four point turns to get around some of the corners on the access road. Road access difficulty has not been addressed.
2. It is obvious that vehicular traffic has to endure tight turns and steep roadway to access from East Mercer Way to the subject lot. Mr. Heavey's calculation of "200 to 226 total truck trips to haul off the excavation spoil" would be actually only half of the trips since 200 to 200 total truck trips are what will be needed just to haul the material off. Another 200 to 226 truck trips would be trucks coming down the hill to access the subject property. In all, based on 4 Season's Homes L.L.C. submittals Mr. Heavey anticipates somewhere between 400 and 450 one-way trips on the subject driveway (200 to 226 round-trip) **just to haul off excavation spoils.**
 - a. The impact of the traffic for the removal of excavation spoils from the site described by Mr. Heavey does not take into account additional heavy equipment traffic:
 - i. excavation equipment to and from the subject property
 - ii. logging equipment and log trailers to and from the subject property
 - iii. concrete trucks to and from subject property
 - iv. concrete pump trucks to and from subject property
 - v. replacement fill delivered by truck for backfilling foundations
 - vi. lumber and construction material trucks to and from property
 - vii. construction labor and supervision traffic to and from subject property
 - b. A January 31, 2017 site visit with Mr. Heavey and a truck driver from Reliable Construction, Inc. was performed. The experienced Reliable Construction, Inc. driver was driving a Kenworth 10/12 dump truck that is typical in the excavation industry. This truck indicated a Gross tare Weight of 56,000 pounds. The reason for the site visit was to observe and photograph the truck heading down the access road [empty] and then turning around and heading back up [empty]. The following issues were observed and discussed with the truck driver:

- i. The length and width of the truck [empty] was not a major concern descending the access road as long as the parking area above the DuBrowa residence (4614 East Mercer Way) was vacant and allowed a large turning radius to get between the uphill rockery and large fir tree. Some back and forth jockeying was required to navigate the tighter turns.
 - ii. Turn around at the base of the access road was difficult and the established round circle turn was too tight for the truck to negotiate.
 - iii. Ascending the access road with the truck [empty] was met with the same challenges save for the turn between the rockery and tree above DuBrowa. The truck driver indicated a full truck the size he was driving would have a distinct probability of encountering the tree occasionally due to the circumstances. In addition if the parking area above the road was occupied with vehicle(s) the access with a large truck would be extremely difficult to negotiate.
 - iv. The truck driver suggested that due to the numerous challenges regarding access with a large truck a "fleet of 5 yard trucks" might lessen the access challenges but the road asphalt surface sub-base and would still be severely compromised due to the heavy traffic.
 - 1. Should the excavation and material import be performed with 5 yard trucks the number of "round trips" to remove 2200 cubic yards of material would also double from 200 to 226 (using a 10-12 yard truck) to 400 to 452 round trips (800 to 904 one way trips).
3. As for the entrance onto and off of E. Mercer Way to the south it is a rather blind corner. Consideration as to trucks pulling onto and off of the steep driveway would require traffic control during most of the project.
- a. There was no discussion as to where construction laborers, subcontractors etc. would park their vehicles during construction. Reviewing Sue Nichol's (horticulturist) review and report, preservation of the trees immediately adjacent to the construction entrance with preclude much off-street parking. According to Ms. Nichol, the following requirements must be added to the permit requirements. It is clear parking, material storage, excavation etc. cannot occur in the "Tree Protection Zone"
 - i. *5. No storage of materials, grading, construction, demolition, or other work shall occur within the tree protection zone.*

CONCLUSION

- 1. That there are "steep slope" areas of the subject property in excess of 40% and approaching 60% should be discussed with the geotechnical engineer and civil engineer for recommendations and/or possible restrictions for development. At least they should be accurately conveyed in the environmental checklist for the Mercer Island City Planners to accurately assess.
- 2. Parking for construction workers and the impact for traffic on E. Mercer Way has not been addressed
- 3. Large truck traffic on the access road and the ramifications have not been studied:
 - a. damage to paved surface roads
 - b. restriction of access to the homes utilizing this sole means of ingress and egress
 - c. as described above, solely for the transport of excavation spoils will require a minimum of 200 to 226 dump truck round-trips. This does not include truck access for delivery and removal of excavation equipment, concrete trucks, concrete pump trucks, construction material delivery or import of suitable soils for backfill. In fact,

due to the restricted width and configuration of the access road in numerous places; smaller trucks may have to be utilized increasing the truck traffic for excavation to an estimated 400 to 452 round trips.

Sincerely yours,

A handwritten signature in cursive script, reading "Michael Showalter", followed by a horizontal line extending to the right.

Michael Showalter, President



Exhibit 14

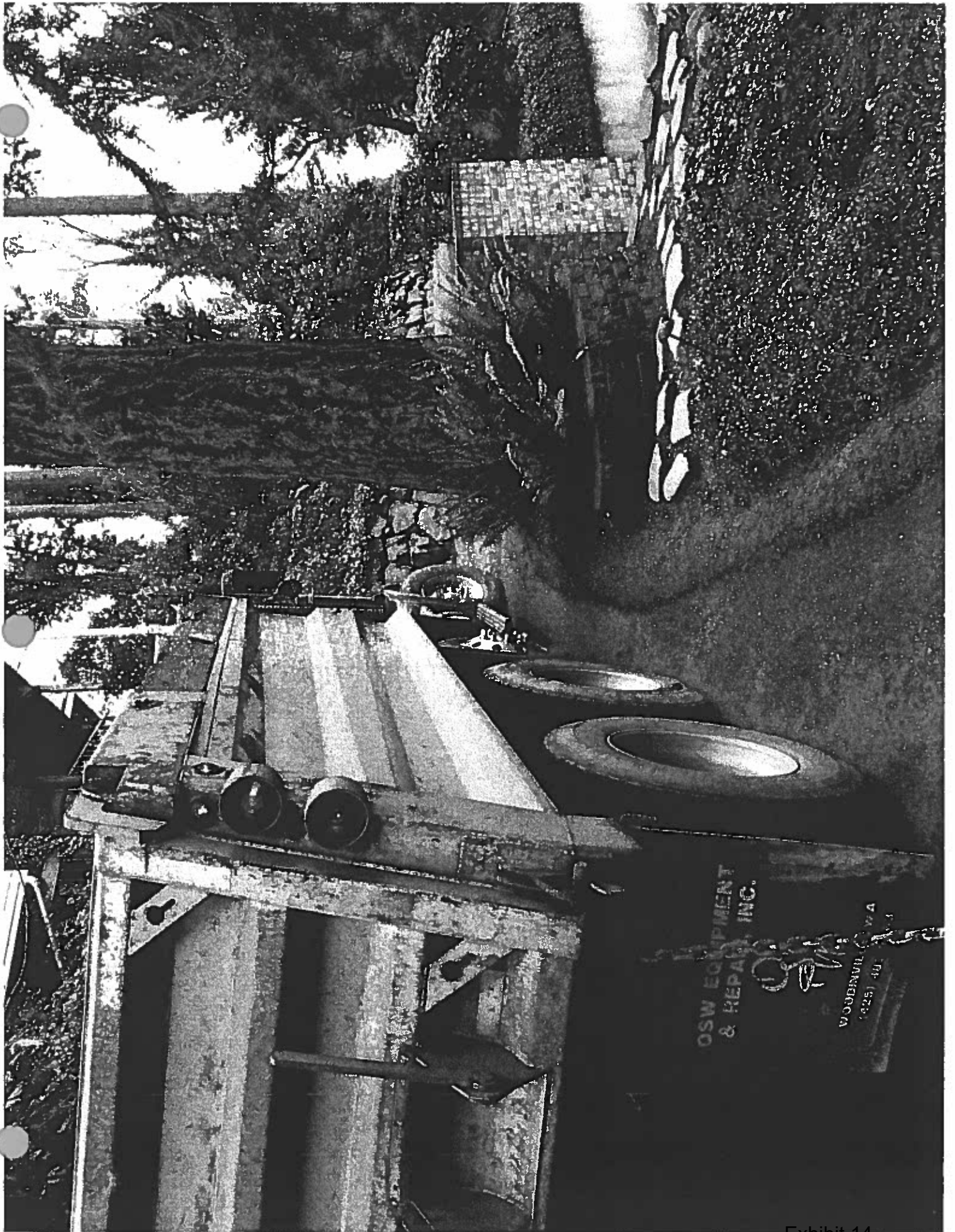

Exhibit 14

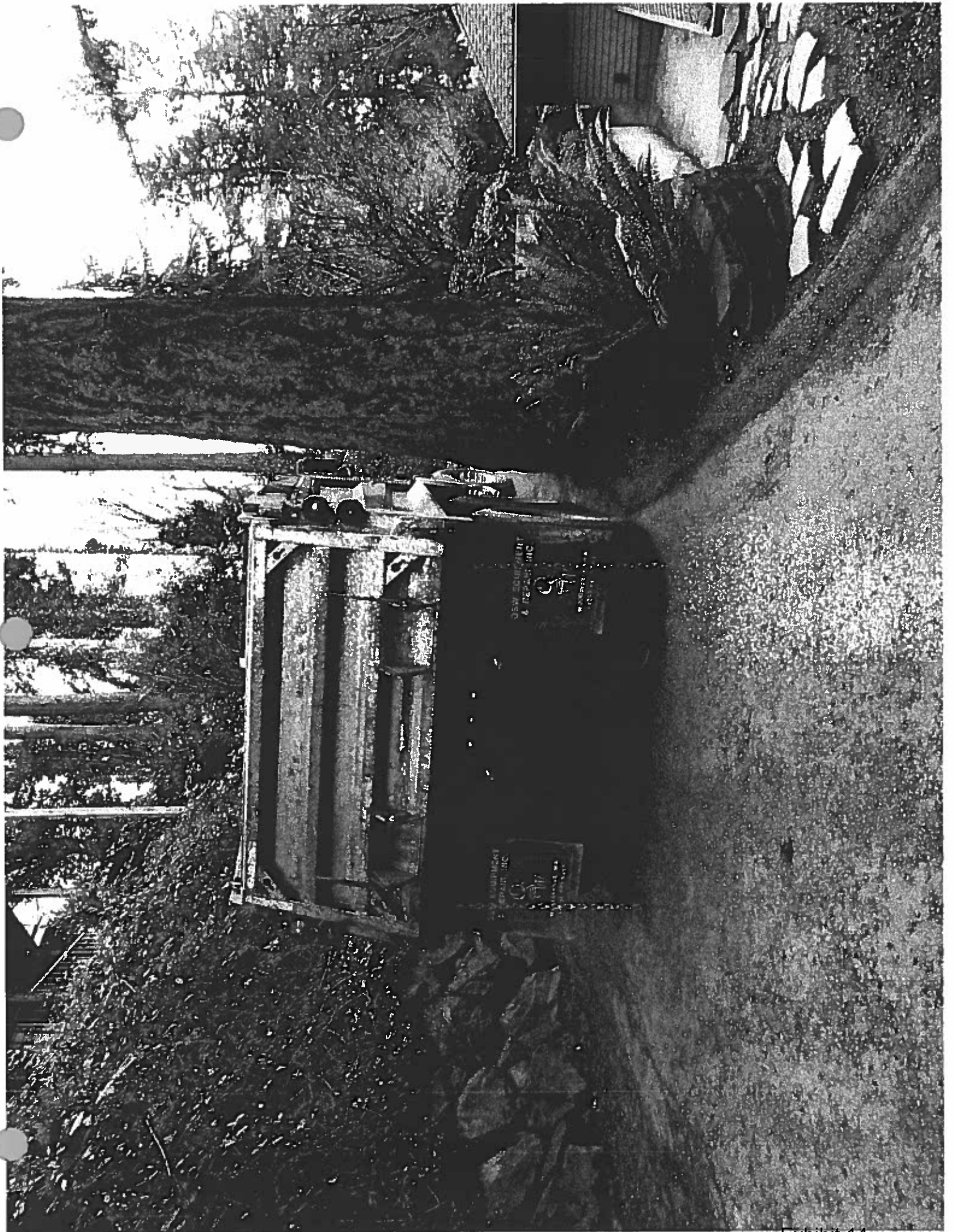

Exhibit 14

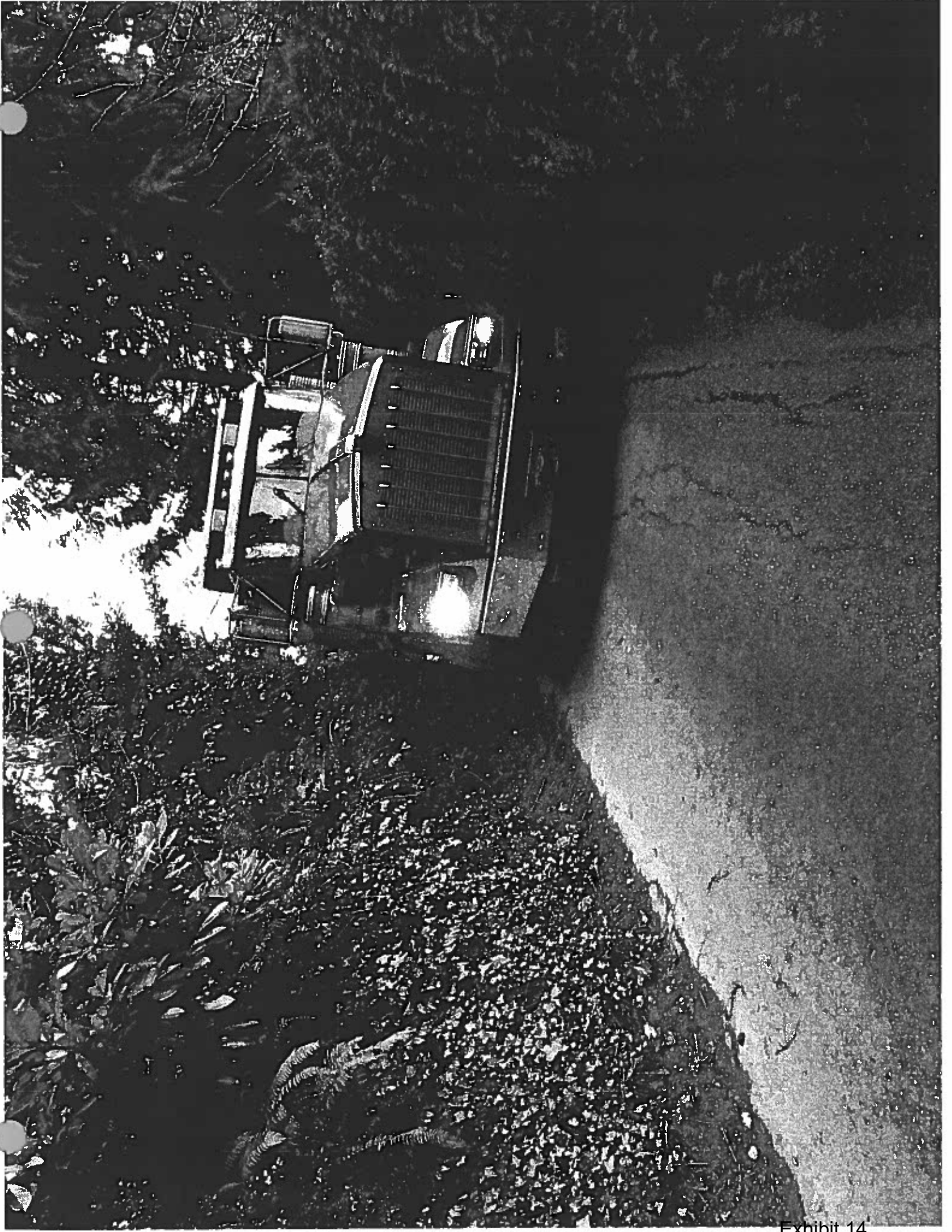

Exhibit 14

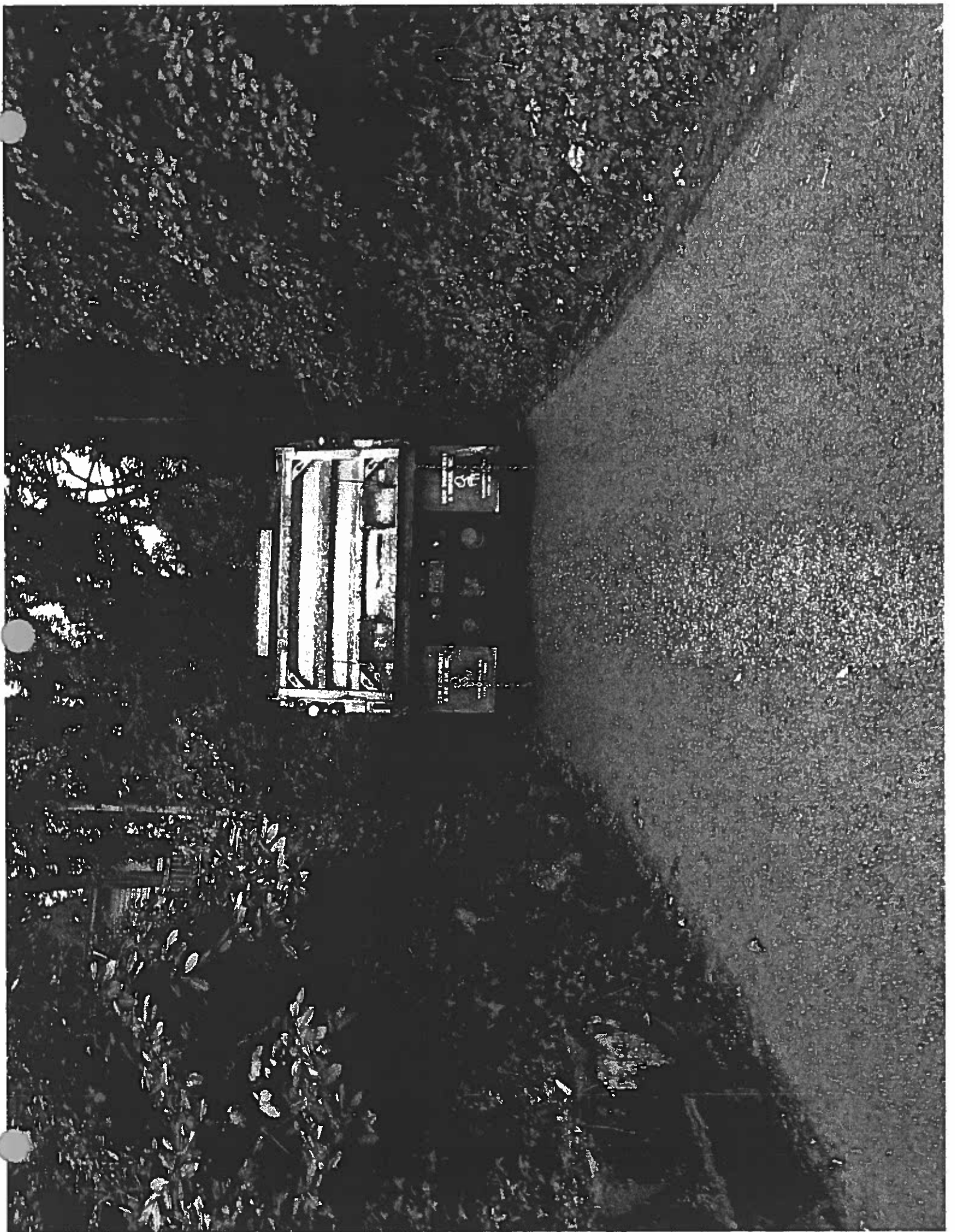

Exhibit 14

February 3, 2017

Stoel Rives LLP
600 University Street, Suite 3600
Seattle, WA 98101

Attn: Rita V. Latsinova

Transmitted via email to: rita.latsinova@stoel.com

Re: **Geotechnical Review of Proposed Single-Family Residence Development**
4634 East Mercer Way, Mercer Island, Washington
City of Mercer Island Permit No. 15-07-166
Project No. 0383008.010.011

Dear Ms. Latsinova:

At your request, I have reviewed the building permit document set and City of Mercer Island (City) Permit No. 1507-166¹ for the proposed single-family residence (SFR) to be located at 4634 East Mercer Way in Mercer Island, Washington (subject property). The following documents were provided for my review:

- *Geotechnical Report Addendum; Evaluation of Surcharge Load on Soldier Pile Wall; Proposed Development; 4634 E Mercer Way, Mercer Island, WA, dated August 12, 2016, prepared for Barcelo Homes, LLC by PanGeo*
- *Statement of Risk; Proposed Development; 4634 E Mercer Way, Mercer Island, WA, dated July 19, 2016, prepared for Barcelo Homes, LLC by PanGeo*
- *Response to Correction Notice #5, dated July 18, 2016, prepared by Andrew Wisdom of Studio 19 Architects*
- **Approved Building Permit Submittal Drawings, including City of Mercer Island Cover Sheet dated August 23, 2016:**
 - *Sheets G0.01 and G0.02, prepared by Studio 19 Architects*
 - *Site Survey: Sheets 1 and 2, prepared by APS Surveying and Mapping*
 - *Civil Drawings: Sheets C1 through C6, prepared by Litchfield Engineering*
 - *Architectural Drawings: Sheets A1.01 through A9.04, prepared by Studio 19 Architects*
 - *Structural Drawings: Sheets S1 through S-10, prepared by Tecinstruct LLC*
- **Conditions of Permit Approval, City of Mercer Island, August 23, 2016.**

¹ Approved by the City on August 23, 2016.

In addition, I have made several visits to the area to observe conditions as they relate to the shared community access road.

Geologic Hazard Areas

Mercer Island City Code (MICC) identifies the site of the proposed development as within a geologic hazard area. Geologic hazard areas are susceptible to erosion, sliding, earthquake, or other geological events. Because of their hazardous conditions, these areas pose a threat to health and safety when development is sited too closely. Geologic hazard areas are regulated mainly for these safety reasons, but they are also regulated for their habitat values. Steep slopes can be conduits for groundwater draining from hillsides to form the headwaters of wetland and streams.

Per section 19.07.060.D.1 of the MIMC, alterations of geologic hazard areas may occur if the code official concludes that such alterations:

- a) Will not adversely impact other critical areas;
- b) Will not adversely impact (e.g., landslides, earth movement, increase surface water flows, etc.) the subject property or adjacent properties;
- c) Will mitigate impacts to the geologic hazard area consistent with best available science to the maximum extent reasonably possible such that the site is determined to be safe; and
- d) Include the landscaping of all disturbed areas outside of building footprints and installation of all impervious surfaces prior to final inspection.

As shown on Figure 1, the shared community access roadway and the area surrounding the proposed development are located within erosion and landslide hazard areas and are critical areas as defined by MICC 19.16.010. Therefore, construction of the SFR at 4634 East Mercer Way in Mercer Island, Washington cannot adversely impact other critical areas and the surrounding properties.

Comments

My review of the materials listed on page 1 revealed no attempt by the City to analyze the adverse impact of the proposed development on "other critical areas" including the shared road, or mitigate any impacts based on best available science, as required by section 19.07.060.D.1 of the MICC.

Based on my own review of the Approved Building Permit Submittal Drawings and conditions observed during several visits to the area, likely adverse impacts to the critical areas surrounding the proposed development include:

- The paved width of the shared access road varies from about 9 1/2 ft to over 15 ft, with an average of about 10 ft. A typical truck is 8 ft in width. According to the June 24, 2015 *Site Development Information Worksheet* prepared by Andrew Wisdom of Studio 19 Architects, the development calls for the excavation of approximately 1,633 in-place cubic yards (cy) of soil. Assuming a typical fluff factor of 25 percent for converting in-place cy to truck cy, gives a total estimated volume of soil to be hauled from the site of about 2,042 cy. Assuming a typical truck capacity of 9 to 10 cy, this equates to a minimum of approximately 200 to 226 total

truck trips to haul off the excavation soil. In addition, concrete trucks, logging trucks, and numerous material supply trucks will need to use the shared access roadway during construction. The pavement at several areas along the shared access road has failed or is showing distress. Based on my experience with roadway design, the existing shared access road is inadequate to handle the expected heavily wheeled construction truck traffic.
Conclusion: The shared access roadway will likely fail, necessitating total replacement.

- The shared access road is relatively narrow (Attachment 1-1: Photographs 1 and 2; Attachment 1-2: Photograph 3). There are only a few places available along the shared access roadway for vehicles to safely pass one another. This will require vehicles to back up to areas where they can safely pass. Portions of the existing access roadway are estimated to have grades between 15 and 20 percent and there are two hairpin turns along the roadway. It will likely be difficult for a fully loaded dump truck, concrete truck, or log truck to drive up the steep portions of the access roadway. The trucks will likely need to use their lowest gear and high engine revolutions in order to climb up the roadway. This will likely result in excessive noise and increased emissions from the diesel trucks.
Conclusion: Since the access roadway is steep and narrow, it is likely that use of the roadway by local residents will be significantly impacted due to construction truck traffic.
- At the top of one of the lower hairpin turns, the road is constricted by a significant, large fir tree on one side and rockery along the other side. The road width is only 14 ft (Attachment 1-2: Photograph 4) at this location. It will be difficult for a 10 cy dump truck to make this turn (Attachment 1-3: Photograph 5) along with concrete trucks and other large trucks.
Conclusion: There is potential for significant damage to the tree and/or rockery.
- Between East Mercer Way and the upper hairpin turn, the slope along the north side of the shared access road descends steeply downward (Attachment 1-3: Photograph 6). I observed several indications of instability of the slope along this portion of the roadway. Several trees were observed to lean backwards (Attachment 1-4: Photograph 7), the fire hydrant is leaning outward (Attachment 1-4: Photograph 8), and two areas along the north edge of the shared access road have subsided (Attachment 1-5: Photographs 9 and 10). Slope instability is likely a result of creep of the surficial soil on the slope below the roadway. Between the two hairpin turns, a steep slope supported by a series of landscape retaining walls is present along the eastern side of the shared access road (Attachment 1-6: Photograph 11). Several large cracks in the pavement (Attachment 1-6: Photograph 12) that parallel the slope face were observed. The cracking is likely due to deflection of the landscape retaining walls and soil creep. The slopes supporting these portions of the shared access roadway may not be able to support the expected construction truck traffic. The project geotechnical engineer should have evaluated the impact of trucks on the stability of the slopes along the access roadway.
Conclusion: In my professional opinion, this will likely increase the potential of a slope failure involving the access roadway and represents a potential public safety hazard.
- The Temporary Erosion and Sediment Control (TESC) Plan (Sheet C4) calls for the temporary construction access roadway to be constructed of quarry spalls. Though required by Note 4 of the approved TESC Plan, no measures are shown to prevent and/or capture runoff and sediment from the construction access road before reaching the shared access roadway. Note 2 of the TESC only requires sweeping of the shared access roadway to remove sediment from the shared access roadway at the end of the day. Even if earthwork will likely occur between April and October of 2017, significant precipitation events can occur in the spring and summer months and uncontrolled runoff from temporary construction access roadway can adversely

impact the residence downgradient from the subject property. Section 1.07.060.D.1.b of the MICC does not allow for increased runoff from geologic hazard areas.

Conclusion: There are inappropriate erosion control measures for the temporary access road, jeopardizing the down gradient property owner.

- All runoff from the shared access road from the lower hairpin turn is collected by a trench drain across the driveway to the residence located at 4632 East Mercer Island Way (Attachment 1-7: Photograph 13). The trench drain may discharge directly to Lake Washington. Without adequate erosion control measures, sediment from the construction site may reach the lake.

Conclusion: There are inappropriate erosion control measures for the temporary access road, exposing Lake Washington to construction sediment flows.

- Sheet 3 of the Civil Drawings show that the lower portion of the driveway is sloped in excess of 20 percent. A single catch basin is shown at the base of the driveway. In my professional opinion, during periods of intense precipitation, stormwater runoff from the driveway will likely overshoot the catch basin and flow down the shared access road. Section 1.07.060.D.1.b of the MICC does not allow for increased runoff from geologic hazard areas.

Conclusion: There is insufficient analysis and design of the stormwater collection system of the driveway, impermissibly exposing the geologic hazard area to increased runoff.

Statement of Risk

Per section 19.07.060.D.2 of the MICC, alteration within geologic hazard areas may occur if the development conditions listed in MICC section 19.07.060.D.1 are satisfied and the geotechnical professional provides a statement of risk with supporting documentation indicating that one of the following conditions can be met:

Statement of Risk. Alteration within geologic hazard areas may occur if the development conditions listed above are satisfied and the geotechnical professional provides a statement of risk with supporting documentation indicating that one of the following conditions can be met:

- a) The geologic hazard area will be modified, or the development has been designed so that the risk to the lot and adjacent property is eliminated or mitigated such that the site is determined to be safe;*
- b) Construction practices are proposed for the alteration that would render the development as safe as if it were not located in a geologic hazard area;*
- c) The alteration is so minor as not to pose a threat to the public health, safety and welfare; or*
- d) An evaluation of site specific subsurface conditions demonstrates that the proposed development is not located in a geologic hazard area.*

MICC 19.07.060.D.2 (emphasis added).

The following specific comments are provided regarding the July 19, 2016 Statement of Risk prepared by PanGeo:

- The Statement of Risk provides no supporting documentation that the requirements of section 19.07.060.D.2 have been met.
- The Statement of Risk states that *"The overall site stability will be greatly improved for the post-construction condition after soldier pile walls are constructed."* Section E on Sheet S10 of the *Structural Drawings* shows a temporary excavation in front of the soldier pile wall along the west side of the house to accommodate construction of the basement foundation. The excavation appears to be about 12 ft deep and sloped at about a 1 horizontal to 1 vertical inclination. The detail indicates that the excavation is to be backfilled after construction of the basement wall, leaving a level surface in front of the soldier pile wall. Review of the soldier pile calculations (Response to Correction Notice #5), indicates that an allowable passive lateral earth pressure of 300 pounds per cubic foot (pcf) was used in the design of the soldier pile wall. In my opinion, an allowable passive lateral earth pressure of 300 pcf would be appropriate if the ground surface in front of the soldier pile wall is level. The soldier pile wall along the west side of the house may undergo unacceptable deflection due to inadequate lateral resistance. The geotechnical engineer and structural engineer should have evaluated and revised the design as necessary.
Conclusion: In my professional opinion, the passive lateral earth pressure inadequately accounts for the temporary excavation in front of the wall, jeopardizing the integrity of the site and presenting a potential safety hazard.
- My review the Approved Building Permit Submittal Drawings and conditions indicates that the erosion control measure are inadequate.
- The slopes supporting portions of the shared access roadway may not be able to support the expected construction truck traffic. This will likely increase the potential of a slope failure involving the access roadway and represents a potential public safety hazard.

In my opinion, the July 19, 2016 Statement of Risk prepared by PanGeo does not fully address the requirements of MICC section 19.07.060.D.2. All critical areas must be designated and their functions and values protected using the best available scientific information - known as "BAS". It does not appear as if BAS was used to evaluate the risk if the development on the surrounding properties. Though the Statement of Risk states that the development has been designed so that the risk to the subject property and adjacent properties has been eliminated or mitigated such that the site is determined to be safe, it provides no supporting documentation for that statement as the code requires. For the reasons described above, it is my opinion there are likely adverse impacts as a result of inadequacy of the soldier pile wall, inadequate erosion control measures, and slope instability along the shared access road.

Other Issues

Other issues to note:

- The City permit conditions require special inspections. The City's cover sheet attached to the approved drawings does not list any required special inspections. The City should list the required special inspections on the cover sheet.
- The shared access roadway joins East Mercer Way on a curve and there is poor site visibility, especially for vehicles traveling north on East Mercer Way (Attachment 1-7: Photograph 14). Without proper traffic control at the intersection, there is an increased risk to motorists and bicyclists traveling on East Mercer Way from construction vehicles entering the roadway.

Based on our review of the approved plans and conditions observed during our visits to the area, it is my opinion that construction of the proposed SFR at 4634 East Mercer Way in Mercer Island, Washington will adversely impact critical areas on adjacent properties, thereby jeopardizing both public safety and property. Therefore, the project should not be allowed per MICC Section 19.07.060.D.1. In addition, the July 19, 2016 Statement of Risk prepared by PanGeo does not fully address the requirements of MICC Section 19.07.060.D.2.

Thank you for the opportunity to be of service on this project. If you should have any questions or require clarification on any of the items discussed above, please call me at (206) 390-8742.

LANDAU ASSOCIATES, INC.

Edward Heavey
Principal

EJH/jrc

[Y:\383\008 #1\0\CRITICAL AREAS COMMENT LETTER\CRITICAL AREAS PERMIT COMMENT LTR.DOCX]



Attachments: Figure 1: Landslide Hazard Map
Attachment 1: Site Photographs

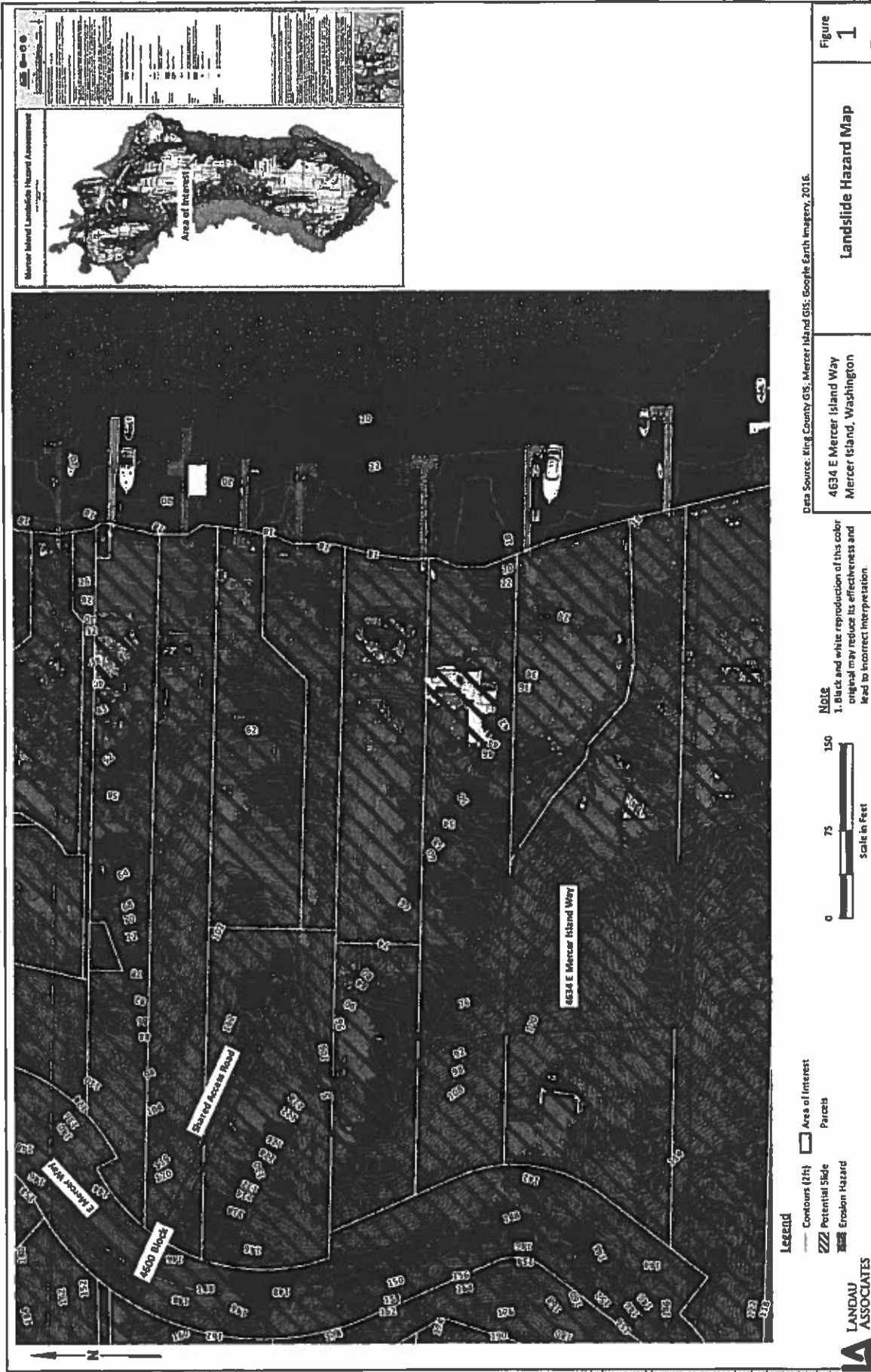

ATTACHMENT 1

Site Photographs



1. Lower portion of access road, looking west from the northeast corner of the subject property.



2. Access road, looking south from upper hairpin turn toward lower hairpin turn.

2/5/17 Y:\3283\008.01\0\1\New\folder\1_1.docx



Single-Family Residence
4634 East Mercer Island Way
Mercer Island, Washington

Selected Site Photographs

Figure
1-1



3. Upper portion of access road, looking west toward East Mercer Island Way.



4. Constricted at lower hairpin turn.

2/3/17 Y:\9831008\010\RVNew folder\1-2.docx



Single-Family Residence
4634 East Mercer Island Way
Mercer Island, Washington

Selected Site Photographs

Figure
1-2



5. A 10-cubic yard truck making turn between large tree and rockery.



6. Slope along upper portion of access road, looking east from East Mercer Island Way.

2/3/17 Y:\380\008\010\RWNew folder\1-3.docx



Single-Family Residence
4634 East Mercer Island Way
Mercer Island, Washington

Selected Site Photographs

Figure
1-3



7. Backward leaning tree along shared access road.



8. Leaning fire hydrant along shared access road.

2/3/17 Y:\383008\010\New folder\1-4.docx



Single-Family Residence
4634 East Mercer Island Way
Mercer Island, Washington

Selected Site Photographs

Figure
1-4



9. Depression and cracking of access road pavement along top of slope.



10. Depression and cracking of access road pavement along top of slope.

2/3/17 Y:\303\008.010\RN\New\objen1_5.docx



Single-Family Residence
4634 East Mercer Island Way
Mercer Island, Washington

Selected Site Photographs

Figure
1-5



11. Retaining walls supporting access road between hairpin turns.

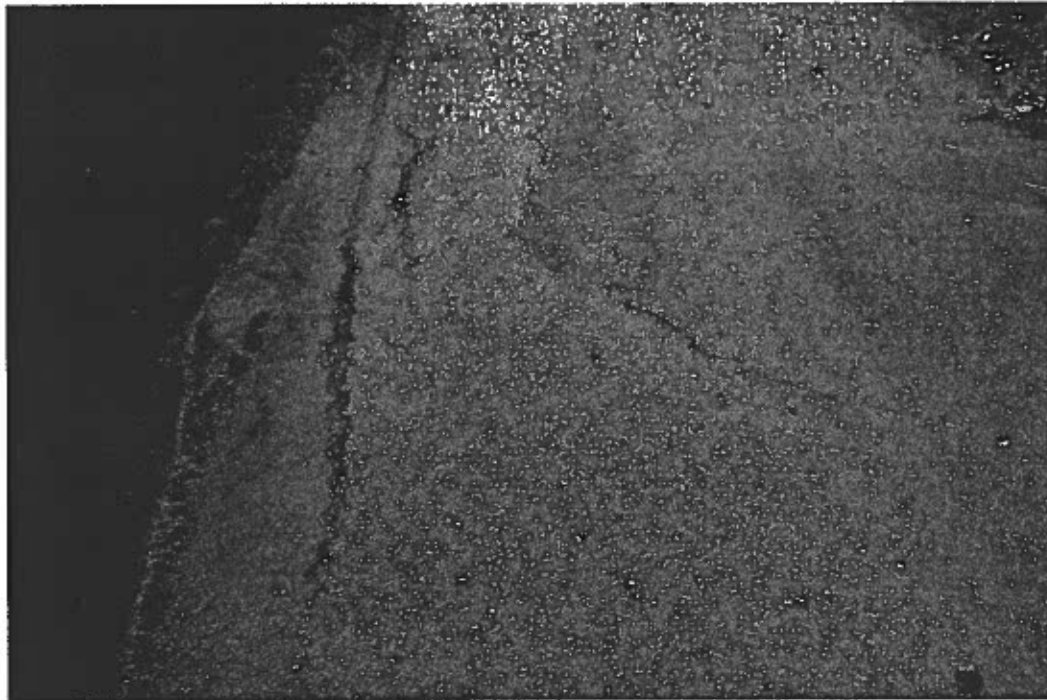

12. Depression and cracking of access road pavement along top of slope.

2/3/17, Y:\3831008.0101R\New folder\1-6.docx



Single-Family Residence
4634 East Mercer Island Way
Mercer Island, Washington

Selected Site Photographs

Figure
1-6



13. Trench drain at east end of access road.



14. Looking north along East Mercer Island Way toward intersection with entrance to access road; photo taken about 100 ft south of entrance.

2/2/17 Y:\3251008.01\DR\New\rdent1-7.docx



Single-Family Residence
4634 East Mercer Island Way
Mercer Island, Washington

Selected Site Photographs

Figure
1-7

G. Robert Rohrbach
Building Code Consultant

February 7 2017

Stoel Rives LLP
600 University Street, Suite 3600
Seattle, Washington 98101

Attn: Rita V. Latsinova

RE: City of Mercer Island Project No. 0383008.010.011

Dear Ms. Latsinova:

You have asked for a summary of my opinions regarding the construction of a new single family residence on a steep slope lot at 4634 East Mercer Way as it relates to Chapter 19 of the Mercer Island Code. I am organizing my thoughts in the order I would propose to present them to the Planning Commission.

Application of MIMC Title 19 to a building permit application

INTRODUCTION. My name is G. Robert Rohrbach. I have over 25 years of experience as a Building Official in 5 different cities, nine of which were spent as the Building Official for the City of Mercer Island. I was involved in daily plan review and site inspections of new construction on Mercer Island, and developed permit application and review procedures to ensure full disclosure of project information in complete application documents. I also participated in the development of Ordinance A-18, known as the Steep Slope Code. This ordinance is now codified in Chapter 19 of the Mercer Island Municipal Code as a part of the environmental review criteria for new development.

Early on in my career as a Building Official, I attended a seminar devoted to reading, writing, and interpreting the language of Building Codes and Municipal Statutes. One of the more important concepts I learned during this seminar was the need to understand the construction of the regulation and how important it is to begin by understanding the definitions, the intent, and the purpose and scope of the regulation or code. The rest of the body of the regulation will flow from these elements and enumerates the details and means of regulating the targeted activity.

DEFINITIONS. I would like to begin with the definitions of slope and steep slope in Title 19 of the MIMC. This is an important starting point in this inquiry because the determination of what regulations apply to the issuance of a building permit for this project is based on which definition applies to the subject site.

- Exhibits showing definitions and site topography.

TITLE 19 REVIEW. In most cities in Washington State, the Building Official is responsible for the administration and enforcement of the building code and its companion codes as promulgated by the State Building Code Council. In the City of Mercer Island, the City Council has added an additional layer of review and enforcement by the adoption of Title 19, which was adopted for the purpose of protecting and promoting health, safety, and the general welfare through the regulation of development within the city of Mercer Island, with special emphasis on the abatement of unsafe and dangerous conditions that can occur as the result of construction on a steep slope or geologically hazardous property.

Because of this additional layer of regulation, the first step the applicant and the Building Official need to take is to analyze the available maps to determine whether the regulations regarding construction in a geologic hazard area will apply and what additional information is necessary to evaluate the project in conformance with the provisions of Section 19.07.060 of the Municipal Code.

As a result of my review of the permit application documents, it is apparent that:

- The applicant did not correctly calculate the slope on the site per the code definitions. This resulted in a project submittal that was lacking in adequate geotechnical review and evaluation, coordination between the design consultants to develop a slope sensitive construction plan and construction sequence, and an adequate site restoration plan.
- It is my opinion that the Building Official did not exercise appropriate caution when reviewing the geotechnical report for this project. I believe that he should have utilized the provisions of Section 19.070.060(C)2 of the MIMC to require peer review of the entire geotechnical report when it has been prepared for construction on a steep slope lot and associated with a waiver of the construction season limitation for a geologic hazard area. Instead, the Building Official required peer review of only the soldier pile design. The peer reviewer concluded that the proposed

design was insufficient and required extensive revisions. This finding leaves doubt as to the adequacy of the balance of the report.

SECTION 19.07.060. Once it is determined that the project is located on a steep slope, the conditions of this section of Title 19 become **the minimum** requirements for the applicant to prove that the project can be constructed in a manner that mitigates the risk of landslide and erosion, without causing damage to adjacent properties or other improvements in geologic hazard areas.

Specifically, Section 19.07.060.C requires the submittal of a comprehensive geotechnical report with design recommendations that are intended to mitigate the risks associated with the slope and soils found on the subject site. Section 19.07.060.D.2 also requires the geotechnical engineer to prepare a statement of risk, **"with supporting documentation"**, indicating that either:

- a) The geologic hazard will be modified, or the development has been designed to eliminate the risk and the site and surrounding properties will be safe, or
- b) Construction practices are proposed for the project that would result in a condition of stability as if the site were not located in a geologic hazard area, or
- c) The alteration is so minor as to pose no threat to surrounding properties, or
- d) An evaluation of site specific subsurface conditions demonstrates that the site is not located in a geologic hazard area.

In this instance, the original geotechnical report by PanGeo did not include a statement of risk. A supplemental report by PanGeo submitted on July 19, 2016 stated that the requirements of section 19.07.060.D.2.b¹ above are met, but without any supporting documentation required by the code. The geotechnical engineer modified his recommendations to include some large concrete blocks to stabilize the cuts into the site, but this recommendation has not been incorporated into the project plans or construction sequencing to ensure the intended stability.

¹ The supplemental report incorrectly cited the city code and erroneously referenced 19.07.060.D.2.c rather than 19.07.060.D.2.b.

Independent of the statement of risk in subsection D.2 above, all four conditions (a) through (d) in Section 19.07.060.D.1 must also be met. Alteration of a critical area is not allowed unless the review demonstrates that:

- a) The project work "**will not adversely impact other critical areas.**"

This requirement has been ignored completely in this application in that there is no mention of protection of off-site properties or the road serving the subject site, which is a private road that traverses multiple geologic hazard areas.

- b) The project will not "adversely impact" (destabilize the site or increase surface water flow) the subject property or adjacent properties;

In this instance, there is no evidence of an evaluation for perched water in the hillside, nor is there a site restoration plan to maintain soil stability and reduce erosion.

- c) The project "will mitigate impacts to the geologic hazard areas consistent with best available science to the maximum effect reasonably possible."

This again should have been reflected in the geological engineer's statement of risk and mitigation proposals and supported by specific design criteria.

- d) The site restoration will be completed per the approved plan.

In this instance, there is no site restoration plan that can be relied on to provide the intended stabilization and erosion control.

Finally, because the project includes a new drainage line running from the site to the shore of Lake Washington, the developer must show compliance with Section 19.07.110, which provides the standards and specifications for work within the shoreline of Lake Washington. My review of the permit drawings reveals that:

- The issue of work in the shorelines of Lake Washington does not appear to have been addressed. There is a large storm drain line of uncertain size, (one note states a 6" line, while another note states a 12" line), proposed in a 5' wide easement running from the subject site to the shore of the lake. It is unclear from the notes and details on pg 6 of the Civil drawings how much of the line will be buried, and it is not clear that

Civil drawings how much of the line will be buried, and it is not clear that the storm line can actually be placed in the 5' easement while avoiding damage to the existing trees in the easement.

- There is also no mention of the shoreline stabilization and net loss of shoreline ecological function in the geotechnical report as required by MIMC 19.07.110 (B) 2. There is also no evidence of a permit from fisheries for work to install a new storm drain outlet into the lake.
- There is no calculation of the amount of excavation required in the 200 foot shoreline management area in order to install the storm drain line. Excavation and/or surface modification in excess of 250 cu yd will require a Shorelines permit. (MIMC 19.07.110(E)Table C.

Conclusions and recommendation. It is my opinion that this application is so lacking in the required information and appropriate detail for a project of this magnitude in a geologic hazard area, it is apparent that the proposed contractor/developer and his design team are equally lacking in the necessary knowledge and experience to adequately pursue this project in the winter months, and the City should withhold any waiver of the seasonal limitations imposed by Section 19.07.060.D.4.

It is also my opinion that because of the serious lack of compliance with Title 19 in the documentation presented by the developer, permit 1507-166 for construction on a steep slope does not comply with the intent and purpose of MIMC Chapter 19 with respect to alteration of geologically hazardous areas. The City should rescind permit 1507-166, and require the completion of adequate studies (including a Critical Area Study, MIMC 19.07.050) to establish that any proposed construction will meet the protections and risk mitigation intended by Title 19 of the MIMC for the subject site, the adjacent properties, the road serving the site, and the shoreline.

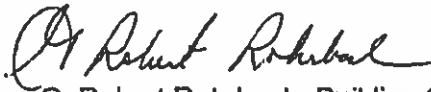

By: G. Robert Rohrbach, Building Code Consultant

October 2, 2015

Stoel Rives LLP
600 University Street, Suite 3600
Seattle, Washington 98101

Attn: Rita V. Latsinova

Transmitted via email to: *rita.latsinova@stoel.com*

Re: **Geotechnical Review**
Proposed Single-Family Residence Development
4634 East Mercer Way, Mercer Island, Washington
Project No. 0383008.010.011

Dear Ms. Latsinova:

At your request, I have reviewed documents submitted to the City of Mercer Island (City) for the proposed single-family residence (SFR) to be located at 4634 East Mercer Way in Mercer Island, Washington (subject property). The following documents were provided for my review:

- *Geotechnical Engineering Study (Revised); Proposed Development; 4634 E Mercer Way, Mercer Island, WA, dated July 11, 2014, revised February 2, 2015 prepared for Barcelo Homes, LLC by PanGeo*
- *Structural Drawings: Sheets S1 through S-9, dated March 11, 2015 prepared by Tecinstruct LLC*
- *Site Survey: Sheets 1 and 2, dated March 15, 2015 prepared by APS Surveying and Mapping*
- *Civil Drawings: Sheets C1 through C4, dated June 16, 2015 prepared by Litchfield Engineering*
- *State Environmental Protection Agency (SEPA) Checklist, dated June 24, 2015 by Andrew Wisdom of Studio 19 Architects*
- *Site Development Information Worksheet for Single Family Residential Development, dated June 24, 2015 by Andrew Wisdom of Studio 19 Architects*
- *Building Permit Submittal Drawings: Sheets G0.01 and G0.02, dated June 24, 2015 prepared by Studio 19 Architects*
- *Architectural Drawings: Sheets A1 through A9, dated June 24, 2015 prepared by Studio 19 Architects.*

In addition, I accompanied you and Mr. Mike Showalter of Construction Dispute Resolution, Inc., to observe site conditions from the shared neighborhood access road.

QUALIFICATIONS

I am a principal geotechnical engineer with Landau Associates with over 29 years of geotechnical experience throughout the Northwest. I am currently providing third-party-peer review services to the

Cities of Edgewood and Federal Way, Washington. My project experience includes major water and sewage pipelines, dams, water reservoirs, wastewater treatment facilities, roads, bridge, and geological hazards assessment, including landslide and slope stabilization. I am highly experienced in geologic hazard assessment and slope stability. A copy of my current resume is attached (Attachment 1).

OBSERVATIONS AND OPINIONS

The following summarizes my observations and opinions regarding the above-referenced development.

Slope Inconsistency

There is inconsistency in the above documents regarding steepness of the slopes at the site of the subject property. In section B.1.b of the *SEPA Checklist*, the steepest slope on the site is stated to be 37.89 percent. The *Site Development Information Worksheet* indicates that the average slope is 37.89 percent. The *Geotechnical Engineering Study* report prepared by PanGeo indicates that the average slope across the site is about 25 percent. It is unclear how PanGeo arrived at this number. The topography shown on the *Site Survey* (Sheet 1 of 2) indicates that portions of the slopes on the site, as measured over a horizontal distance of at least 30 feet (ft), are between 50 and 60 percent. A markup of the *Site Survey* (Sheet 1 of 2) showing three slope areas that are in excess of 50 percent is attached (Attachment 2). According to the City's requirements where critical slopes are greater than 50 percent, no development is allowed and no impervious surfaces are permitted, unless the applicant can demonstrate through professional reports that the public's health, safety, and welfare will not be compromised. In addition, with slopes greater than 50 percent, the lot coverage requirements may be different than assumed for the proposed development.

Existing Access Road

The existing access road was observed to consist of few inches of asphalt; subgrade support conditions for the access road are marginal at best. As stated in Section A.11 of the *SEPA Checklist*, the development calls for the excavation of approximately 1,633 in-place cubic yards (cy) of soil. Assuming a typical fluff factor of 25 percent for converting in-place cy to truck cy, gives a total estimated volume of 2,042 cy of soil to be hauled from the site. Assuming a typical truck capacity of 9 to 10 cy, this equates to a minimum of approximately 200 to 226 total truck trips to haul off the excavation soil. In addition, concrete trucks, logging trucks, and numerous material supply trucks will need to use the access road during construction. Based on our experience with roadway design, the existing access road is inadequate to handle the expected construction truck traffic. It is likely that the existing access road will fail, necessitating total replacement.

The width of the access road varies from about 9½ ft to over 15 ft. A typical truck is 8 ft in width. There are a few places available along the access road for vehicles to safely pass one another. There are

limited areas where a truck can turn around. It may be necessary for the trucks to back down the access road to the site. Portions of the existing access road are estimated to have grades between 15 and 20 percent. It will likely be difficult for a fully loaded dump truck or log truck to drive up the steep portions of the access roadway. The trucks will likely need to use their lowest gear and high engine revolutions in order to climb up the roadway. This will likely result in excessive noise and increased emissions from the diesel trucks. Given how steep and narrow the access road is, it is likely that there will be significant impacts to the residents along the access road due to construction truck traffic.

The access road (4600 block) joins East Mercer Way on a curve and there is poor site visibility for vehicles traveling north on East Mercer Way. Without proper traffic control at the intersection, there is an increased risk to motorists and bicyclists traveling on East Mercer Way from construction vehicles entering the access road.

The temporary construction access road into the site will likely be sloped at least 20 percent. It is impractical for a dump truck or log truck to access the site using such a steep roadway. Therefore, the trucks will likely have to be loaded out while sitting in the access road. This will negatively affect the residents who share the access road.

The Temporary Environmental and Sediment Control (TESC), Plan Sheet C4 of the *Civil Drawings* calls for the temporary construction access roadway to be constructed of quarry spalls. No provisions are shown on the TESC Plan as to how runoff from the temporary construction access roadway will be retained on the site. Even though earthwork will likely occur between April and October of 2016, significant precipitation events can occur in the spring and summer months and uncontrolled runoff from the temporary construction access road can adversely affect the residence downgradient from the subject property.

Tree Drip Line

There appears to be an inconsistency with the size of the radius of the tree drip line circles shown on the *TESC Plan* (Sheet C4) and Sheet A1.01 of the *Architectural Drawings*. The proposed temporary access road and proposed temporary stockpile area shown on drawing C4 would be within the tree drip line radius shown on drawing A1.01. If the radii of the tree drip lines circles are incorrectly shown on drawing C4, there is a potential for negative impacts to the trees that are to remain. Drawing A1.01 also indicates that there will be clearing and grading activities within the tree drip line circles, such as trenching for the site utilities, construction of retaining walls, and fill placement downslope and upslope of the proposed subject property.

CONCLUSIONS AND RECOMMENDATIONS

In my opinion, there are several issues that warrant additional investigation by the City. These include:

- Lot coverage requirements, given that there are slopes of up to 60 percent on the property
- Noise and air impacts from construction trucks
- Impacts to East Mercer Way for construction traffic
- Ingress and egress impacts due to construction truck traffic
- Impacts to the shared access roadway from construction truck traffic
- The potential for stormwater runoff from the temporary access roadway
- Impacts within the tree drip line circles due to excavation and grading activities at the site.

Thank you for the opportunity to be of service on this project. If you should have any questions or require clarification on any of the items discussed above, please call me at (253) 284-4875.

LANDAU ASSOCIATES, INC.

Edward J. Heavey
Principal

EJH/jrc
(Y:\1383\008.010\1\DU BROWA COMMENT LETTER.DOCX)

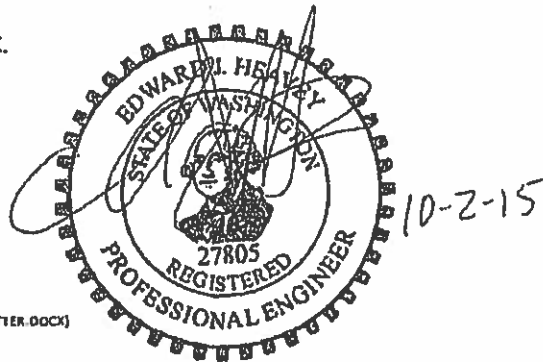

Attachments: Attachment 1: Edward J. Heavey Resume
Attachment 2: Marked-up Site Survey Map

Edward J. Heavey Resume

Ed Heavey, P.E.

Principal, Geotechnical Engineer

Expertise

Project management

Geotechnical engineering

Slope stability and slope deformation analysis

Trenchless technology

Seismic engineering

Geologic hazard assessment

Construction support

Education

M.S., Geotechnical Engineering, University of Washington, 1987

B.S., Geological Sciences, University of Washington, 1982

Registration

Professional Engineer (Civil): 1991/Washington, No. 27805

Ed is a principal geotechnical engineer with more than 29 years of experience assisting public agencies and private clients with design and construction of major water and sewage conveyance pipelines, pump stations, wastewater treatment facilities, storm drainage facilities, slope stabilization, roads and bridges, water reservoirs, buildings and educational facilities. Ed has extensive experience providing a wide range of geotechnical engineering support services such as geological hazards assessment, forensic studies, expert testimony/ litigation support, critical area reviews, third party peer reviews, pavement design, seismic engineering and construction support for a wide range of municipal clients.

City of Tacoma, North Waterview Stabilization Project Pond Evaluation; Tacoma, WA. Project manager for geotechnical services to the City of Tacoma for the repair of a landslide that occurred in the 4600 block of North Waterview Street in Tacoma. The landslide took out almost the entire roadway width. A soldier pile wall with permanent tieback anchors was constructed to retain the roadway across the slide area. Landau Associates completed geotechnical explorations to characterize near surface soil and groundwater conditions, developed geotechnical design recommendations for the soldier pile wall. Landau Associates also provided geotechnical support during construction of the soldier pile wall.

City of Edgewood, On-Call Geotechnical Consulting Services; WA. Contract manager and project manager for geotechnical engineering services to the City of Edgewood from 2001 through the present. Services included providing geotechnical third party peer review of projects proposed in critical areas, geotechnical consulting regarding roadways and utilities within the City, assisting the City in construction oversight in critical areas, and emergency services related to slope failures impacting City right-of-way and failures/damage to City-maintained infrastructure.

Boulevard Road/Log Cabin Road Intersection Improvements; Olympia WA. Project manager for geotechnical services for improvements to the intersection of Boulevard Road and Log Cabin Road. Improvements consisted of constructing a new two-lane roundabout and extending Log Cabin Road to the east to serve a proposed new residential development. Sloped embankments and mechanically stabilized earth (MSE) walls were utilized to retain cuts and fills to accommodate the roadway widening. Recommendations included an assessment of the landslide hazard areas on the site; an evaluation of the stability of the steep slopes located in the roadway corridor; site grading; installation of new underground utilities; criteria for design of gravity, MSE, and soldier pile retaining walls; pavement design; and an assessment of the infiltration capabilities of the near-surface soils based on the City of Olympia Stormwater Management Manual method (2005) and the results of an aquifer pumping test.

Pierce County, On-Call Geotechnical Consulting Services; WA. Project manager for providing geotechnical and environmental services to Pierce County Public Works and Utilities for on-call geotechnical consulting services. Projects have included roadway realignment and widening, pavement design, bridge foundations, sanitary sewer stormwater conveyance and treatment facilities, infiltration facilities, environmental investigation for characterization of soil/groundwater contamination, right-of-way acquisition support, and other infrastructure-related issues.

Pacific Hwy S HOV Lanes Phase IV; Federal Way, WA. Project manager for geotechnical and environmental services provided to KPG and Federal Way to support the widening of Pacific Highway South between South 312th Street and Dash Point Road. The project includes both state and federal funding. Geotechnical services included field explorations, developing geotechnical recommendations for site grading, subgrade preparation for pavements), geotechnical parameters for construction of retaining structures, a corridor-level Phase I environmental site assessment (ESA) for the right-of-way acquisition, a full Phase I ESA and Phase II ESA on a property with identified soil and groundwater contamination. We also provided geotechnical services during roadway construction.

Marked-up Site Survey Map

| | | | | | |
|----------------------|--|----------------------------|--|--------------|--|
| DATE: 5/17/75 | | APPROX PROJECT NO.: 100000 | | JOB AND MARK | |
| DUNCAN BLAND | | | | | |
| DUNCAN BLAND | | | | | |
| 4004 EAST MERCER WAY | | | | | |
| AS-BUILT SURVEY of | | | | | |
| DUNCAN BLAND | | | | | |
| WASHINGTON | | | | | |
| APPROVED BY: _____ | | | | | |
| DATE: _____ | | | | | |
| DRAWN BY: _____ | | | | | |
| CHECKED BY: _____ | | | | | |
| SCALE: _____ | | | | | |
| SHEET NO. 2 OF 1 | | | | | |

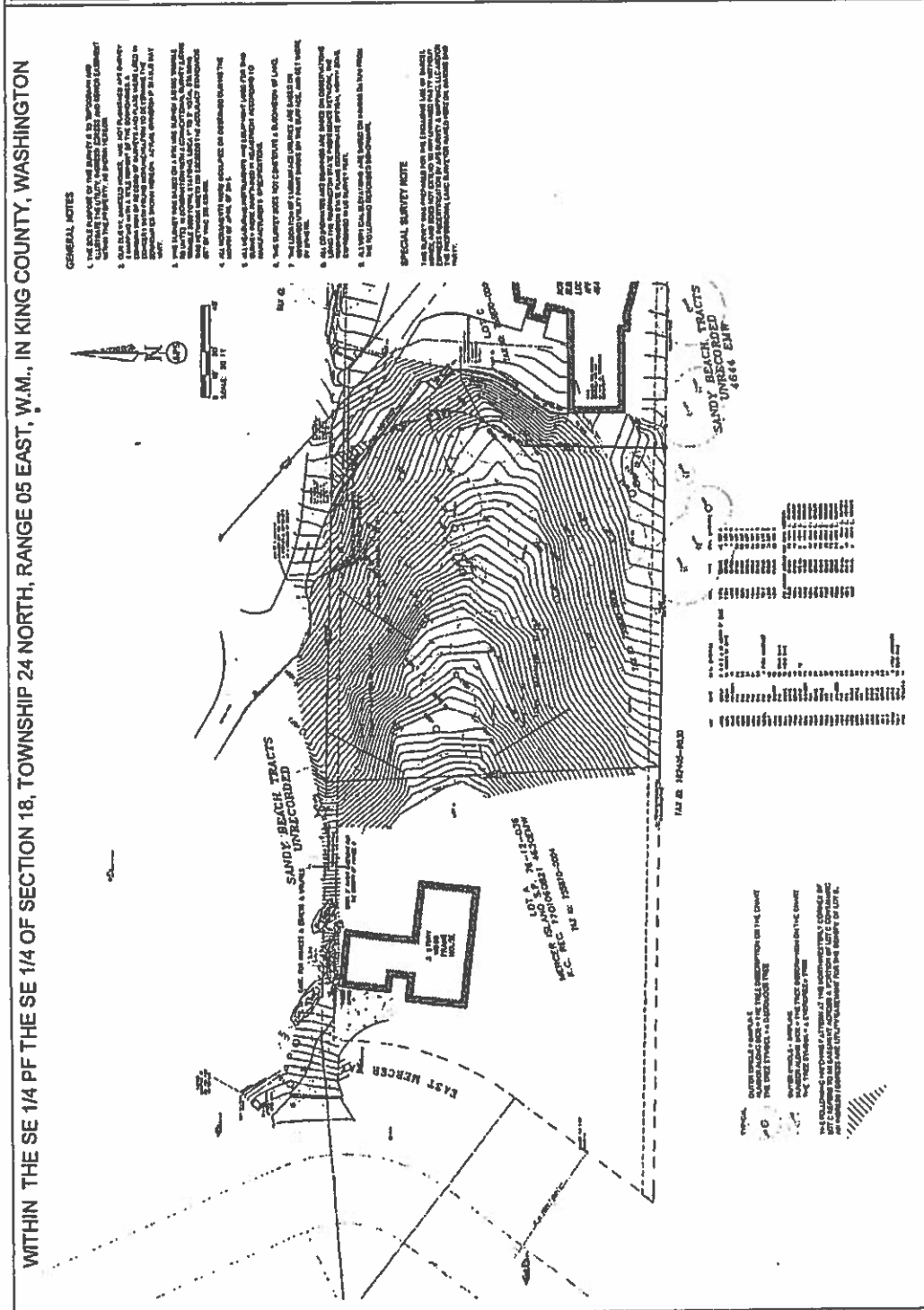

WITHIN THE SE 1/4 OF SECTION 18, TOWNSHIP 24 NORTH, RANGE 05 EAST, W.M., IN KING COUNTY, WASHINGTON

GENERAL NOTES

1. THE BOUNDARIES OF THIS SURVEY ARE BASED UPON THE SURVEY OF THE SANDY BEACH TRACTS UNRECORDED, AS SHOWN ON THE PLAT THEREOF, AND THE SURVEY OF THE SANDY BEACH TRACTS UNRECORDED, AS SHOWN ON THE PLAT THEREOF.
2. THE SURVEY WAS MADE BY THE SURVEYOR AND HIS ASSISTANTS, AND THE SURVEYOR IS NOT RESPONSIBLE FOR ANY ERRORS OR OMISSIONS IN THE SURVEY.
3. THE SURVEY WAS MADE BY THE SURVEYOR AND HIS ASSISTANTS, AND THE SURVEYOR IS NOT RESPONSIBLE FOR ANY ERRORS OR OMISSIONS IN THE SURVEY.
4. ALL DISTANCES ARE GIVEN IN FEET AND DECIMALS THEREOF.
5. ALL ANGLES ARE GIVEN IN DEGREES AND MINUTES.
6. THE SURVEY WAS MADE BY THE SURVEYOR AND HIS ASSISTANTS, AND THE SURVEYOR IS NOT RESPONSIBLE FOR ANY ERRORS OR OMISSIONS IN THE SURVEY.
7. THE SURVEY WAS MADE BY THE SURVEYOR AND HIS ASSISTANTS, AND THE SURVEYOR IS NOT RESPONSIBLE FOR ANY ERRORS OR OMISSIONS IN THE SURVEY.
8. ALL DISTANCES ARE GIVEN IN FEET AND DECIMALS THEREOF.
9. ALL ANGLES ARE GIVEN IN DEGREES AND MINUTES.
10. THE SURVEY WAS MADE BY THE SURVEYOR AND HIS ASSISTANTS, AND THE SURVEYOR IS NOT RESPONSIBLE FOR ANY ERRORS OR OMISSIONS IN THE SURVEY.

SPECIAL SURVEY NOTE

THIS SURVEY WAS MADE FOR THE PURPOSE OF DETERMINING THE BOUNDARIES OF THE SURVEY AND THE SURVEYOR IS NOT RESPONSIBLE FOR ANY ERRORS OR OMISSIONS IN THE SURVEY.

DATE: 5/17/75

DUNCAN BLAND

APPROVED BY: _____

DATE: _____

DRAWN BY: _____

CHECKED BY: _____

SCALE: _____

SHEET NO. 2 OF 1

CITY OF MERCER ISLAND

DEVELOPMENT SERVICES GROUP

9611 SE 36TH STREET | MERCER ISLAND, WA 98040
PHONE: 206.275.7605 | www.mercergov.org



CONDITIONS OF PERMIT APPROVAL

Date: 8/23/16 Permit Number: 1507-166
Name: Barcelo Homes Rebuild SFR Address: 4634 E Mercer Way

City inspections are required for all phases of work. Schedule inspections online at MyBuildingPermit.com or call (206) 275-7730 and leave a voicemail message.

General

1. These conditions are part of your plan approval. Failure to comply could result in a stop work order and/or fine. This document must be read and signed by the owner/representative prior to construction.
2. Mechanical, plumbing, and electrical work are covered under your building permit only if you have paid the fee for a combination permit. If you do not have a combination building permit, separate permits will be required for mechanical, plumbing, and electrical work.
3. A separate permit is required for demolition, side sewer, water meter, right-of-way, rockery, retaining wall, grading, tree, fire protection, and irrigation work.
4. A pre-construction meeting between City Staff and the owner, contractor, or responsible representative will be required on all projects that have a stormwater permit, new water service, or more than 500 sf. of new impervious surface per Mercer Island City Code (MICC) 19.07.010 (A)(4). A pre-construction meeting may also be required as determined by City Staff. Call the In section Request Line at (206) 275-7730 to schedule a meeting 24-hours prior to the start of construction.
5. The approved plans and building permit are to be at the building site at all times. Place in a protected, but available location.
6. Build from the permitted set of plans *only*. Do not remove any attachments to the plans. Additional copies of the permit plan sets may be purchased through the City if needed for sub-contractors, etc.
7. This permit is issued based upon the assumption and certification that the owner controls all rights to develop this property as proposed, including the air-rights to accommodate the height of the structure(s).
8. The City requires a three-day advanced notification for all final inspections. All other permits including tree, fire, site restoration, double check valve assemblies, right-of-way use, etc. must be complete before final building inspection can be scheduled.
9. MICC 19.09.050 (4)(G) requires that house numbers be provided that are at least 6 inches in height, are on a contrasting background, and are located in a readily visible location from the roadway.

10. Noise from heat pumps, air handlers, generators, etc. shall not exceed the parameters in WAC Section 173-60-040. A sound measurement must be taken at the point of the receiving property nearest to the source. This is to be performed by the installer. A certification form (provided by the City) is to be signed by the installer guaranteeing compliance with state law. This certification must be provided prior to the final inspection.
11. A field survey during construction is required to verify the height of any structure that is within 2 feet of the allowable height specified by the Mercer Island City Code. Contact the Development Services Group at (206) 275-7605 for questions or more information about this requirement.
12. Concrete mixers and concrete pumpers are not to be washed out into any catch basin or onto public property.
13. New mailbox locations must be approved by the Postmaster. You must contact Paula Nowell at 206-275-1194 or paula.a.nowell@usps.gov for approval.
14. Business Licenses are required. A business license from the City of Mercer Island is required for all subcontractors that will be conducting, maintaining, operating or engaging in business within the City limits during any tax year; this includes all subcontractor work at job sites on Mercer Island. This general license is issued annually and grants the business owner the right to conduct business within the City of Mercer Island. The fee for the Business License is \$30.00 per year and must be obtained prior to starting work. A business license application can be obtained by visiting the Finance Department at City Hall, by downloading the application from the City website at www.mercergov.org/businesslicenses, or by calling the Business License Division of the Finance Department at 206-275-7783.
15. Subcontractor List required. As a condition of this permit approval, the permit holder (building owner or general contractor) is responsible for the completion of the List of Subcontractors that was provided at the time of permit issuance. The completed List shall be returned to the Finance Department at least thirty days prior to Final Inspection. If you have questions, please call 206-275-7783.

Construction Parameters

1. Hours of work are 7:00 a.m. to 10:00 p.m. Monday through Friday (except holidays) and 9:00 a.m. to 10:00 p.m. Saturday, Sunday and holidays.
2. All public access roadways are to be restored to the existing condition prior to the project (pictures before start of work recommended). All access roads are to remain clean.
3. The City is to be provided with the name and license numbers (state contractor's and City business license) of the contractor and sub-contractors prior to any inspection (MICC 5.01.040).
4. Any changes to the siting or construction of this building require prior approval by City Staff.

Construction Vehicle Parking

1. On-site parking shall be established within 7 days from the start of construction activity. The provided parking capacity shall be sufficient for all anticipated construction vehicles. If sufficient on-site parking cannot be provided, the contractor shall find alternative off-site parking locations not on City of Mercer Island Streets and shuttle workers onto the site.
2. The Owner or Contractor shall apprise all subcontractors of these parking requirements upon their arrival on the job site.
3. Construction vehicles shall be parked in a manner that minimizes their impact on the neighborhood. A limitation on construction vehicle parking within the City right of way may result if it is determined that construction parking adversely impacts normal neighborhood activity.

4. Vehicles shall not be parked along any City street or right-of-way for more than a 72 hour period (MICC 10.36.225).
5. Do not park any vehicle along a City street within eight feet of the centerline of a two-lane roadway (MICC 10.36.226).
6. Do not stop or park a vehicle in such a position as to block the driveway entrance to any abutting property. Do not use any neighborhood driveway for vehicle turnaround purposes without the prior written permission of the property owner(s). Do not park within an alley or private road in such a manner as to leave available less than eight feet of the width of the roadway for the free movement of vehicular traffic (MICC 10.36.227).
7. The City of Mercer Island Fire Department may perform site visits to verify emergency vehicle access is maintained.
8. Additional parking restrictions may be required if it is determined that construction parking adversely impacts normal neighborhood activities or on projects extending beyond a one-year duration.

Erosion Control

1. Erosion control and Tree Protection are your first inspections. These inspections may be done along with the pre-construction inspection (if required).
2. All tree protection fencing needs to be in place at drip-lines or beyond before any work begins on the property.
3. Properly install sediment and erosion control measures as noted on the approved site plans (MICC 19.07.010). All sediment and erosion control features must be installed and inspected prior to the start of any land-disturbing activity. No construction activity shall be inspected (foundation, etc.) prior to an approved erosion control inspection. All erosion and sediment control features are required to be maintained for the duration of the project and are subject to inspection at any time. All "land disturbing activity" is subject to provisions of MICC 15.09.
 - a) Protect adjacent properties from any increased runoff or sedimentation due to the construction project through the use of appropriate "best management practices" (BMP). Examples include, but are not limited to, sediment traps, sediment ponds, filter fabric fences, vegetative buffer strips, or bioengineered swales.
 - b) Construction access to the site should be limited to one route. Stabilize entrance with quarry spalls to prevent sediment from leaving the site or entering the storm drains. A Right-of-Way permit may be required for this construction.
 - c) Prevent sediment, construction debris, paints, solvents, etc. or other types of pollution from entering public storm drains. Contain all pollution on your site.
 - d) All exposed soils shall remain denuded for no longer than two (2) days from October 1st to April 30th and not longer than seven (7) days from May 1st to September 30th. All soils shall be stabilized with mulch, hay, a plastic covering, or other appropriate ground cover. All exposed soils shall be covered immediately during any rain event.
4. You are responsible for controlling all silt runoff and are responsible for any costs incurred in any required cleanup. Immediate response by you is required in the event of any level of damage to adjacent properties, which are a result of your project.
5. Silt fence: clean and provide regular maintenance of the silt fence. The fence is to remain vertical and is to function properly throughout the term of the project.
6. See the approved site plan/erosion control plan for additional specific requirements.

7. Site Development

1. Work in the public right-of-way requires a separate permit. Contact the City of Mercer Island Development Engineer at least 2 days before you need to use the public right-of-way to allow proper review time before the right-of-way use permit can be issued.
2. Verify locations and depths of utilities prior to any excavation. Do not build over the side sewer. Call "One Call" at 1-800-424-5555 at least 48 hours prior to construction.
3. Roof drains must be connected to the storm drain system and inspected by the Utility Site Inspector prior to any backfilling of pipe. Call (206) 275-7714 24 hours prior to inspection.
4. Installation of concrete driveways, trees, shrubs, irrigation, boulders, berms, walls, rockeries, gates, and other improvements are not allowed in the public right-of-way without a prior approved and recorded Encroachment Agreement and Right-of-Way Use Permit from the Senior Development Engineer.
5. Fire hydrants shall not be used as a source of water for construction projects without prior approval from the Mercer Island Maintenance Department. See the Finance Department to pay a deposit for a double check valve assembly and meter.
6. The contractor shall not use water from new water services until a water meter has been installed. The water meter shall be installed as soon as possible after construction of the water service.

Building Requirements

1. Structural observation by the Engineer of Record per IBC 1702.1 is required for all components of the lateral force resisting system, including nailing, bolting, anchoring, drag struts, braces, hold-downs, and other lateral force resisting elements. Alternatively, provide periodic special inspection per IBC 1707.3 by a WABO Certified Lateral Wood Special Inspector. A report by the engineer or special inspector (per IBC 1709.1 or 1704.1.2 respectively) shall be provided to the City Building Inspector prior to the required framing inspection. **NOTE: A framing inspection by the City Building Inspector is required in addition to the structural observation or special inspection noted above. Do not cover or conceal framing or any lateral force resisting elements prior to the City framing inspection.**
2. Land clearing, grading, filling, and foundation work are not permitted between October 1st and April 1st on lots due to the critical slopes or geologic hazard (MICC 19.07.060).
3. Moratorium Deviation Approved, DEV10-0xx. Weekly reports shall be submitted until all earth-disturbing activities are completed.
4. Reference the attached City of Mercer Island coversheet for required special inspections and geotechnical inspections.

Civil Engineering/Utility Requirements

1. All staging and storage shall occur on site.
2. Do not backfill with native material on public right of way. All material must be imported.
3. Refer to water service permit for actual location of new water meter and service line determined by Mercer Island water Department.
4. A side sewer back flow preventer is required for the side sewer system.
5. No ADS flexible pipe shall be allowed.
6. Sand Collars are required for grouting PVC pipe to concrete structures. This also applies to ADS N-12 pipes and HDPE pipes.

7. Owner shall control discharge of surface drainage runoff from existing and new impervious areas in a responsible manner. Construction of new gutters and downspouts, dry wells, level spreaders or downstream conveyance pipe may be necessary to minimize drainage impact to your neighbors. Construction of minimum drainage improvements shown or called out on the plan does not imply relief from civil liability for your downstream drainage.
8. The contractor must pot hole all utilities prior to making connections to verify material, diameter, alignments, etc. Prior to making connections, contractor shall have all necessary parts, materials and equipment on site. Contact Site & Utilities inspector to verify.
9. Catch basin filter/sock should be provided for all storm drain catch basins/inlets downslope and within 500 feet of the construction area. Catch basin filters should be designed by the manufacturer for use at construction sites and approved by the city inspector. Catch basin filters should be inspected frequently, especially after storm events. If the filter becomes clogged, it should be cleaned or replaced.
10. The TV inspection of the existing side sewer to the city sewer main is required. If the result of the TV inspection is not in satisfactory condition, as determined by the City of Mercer Island Inspector, the replacement of the existing side sewer is required. Alternately, a pressure test of the side sewer, from sewer main to point of connection, may be substituted for the video inspection.
11. Newly installed side sewer requires a 4 p.s.i. air test or provide 10' of hydrostatic head test.
12. Pot holing the public utilities is required prior to any grading activities less than 6" over the public mains (water, sewer and storm systems). If there is a conflict, the applicant is required to submit a revision for approval prior to any grading activities over the public mains.
13. The limits and extends of the pavement in the public right of way shall be determined by the City engineer prior to finalize the project.
14. All utility work must be either on the subject property or within the limits of the existing private easements. No work outside the property or outside the existing private easements are allowed under this permit, unless there are written agreements from the neighboring property owners.
15. As-built drawings are required for water service, water supply lines, storm drainage, and side sewers prior to backfill. Storm detention systems and complex improvements in the City Right-of-Way require a full size as-built drawing.

Fire Requirements

Inspection Scheduling:

Most residential sprinkler, fire alarm and final fire inspections require a three day notice. Please schedule online at <https://inspection.mybuildingpermit.com/> or by calling the Inspection Request Line at (206) 275-7730. Please contact the Fire Marshal's office at (206) 275-7966 to confirm inspection availability.

Conditions:

The checked items below are conditions of permit approval for this project. These conditions contain information that must to be provided to the various contractors, for example: information regarding the fire and water service for the plumbing contractor, fire alarm requirements for the electrical contractor, sprinkler coverage and design requirements for the fire sprinkler contractor, etc.

- Fire Alarm requirements shall consist of:

- Low voltage Household Fire Alarm System per NFPA 72 Chapter 29 and monitored by UL Central Station.
- Local water flow alarm only.
- Local water flow alarm monitored by Central Station (via listed auto-dialer).

Note: At a minimum, all local water flow alarms shall consist of an interior water flow alarm and an outside water flow bell. The interior water flow alarm may utilize a UL Listed relay to connect compatible line voltage smoke alarms (for example, FIREX relay module # 0498 with the FIREX smoke alarms, Kidde relay/power supply module SM120X with the KIDDE smoke alarms, etc.). The outside water flow bell shall be at least an 8-inch bell and approved for exterior locations (e.g.—Potter water flow bell, etc.). Where fire alarm systems do not require monitoring by a Central station, an approved permanent sign shall be installed adjacent to each fire alarm box that reads: **WHEN ALARM SOUNDS—CALL FIRE DEPARTMENT**. Accounts for Central station monitoring must be in place before the final flow test is performed.

- Fire Sprinkler system is required to protect the following areas:
 - Entire Dwelling
 - Additions only (note – this partial sprinkler system requires that the sprinklered area be compartmentalized from surrounding areas).
- Fire Sprinkler system shall be installed in accordance with the following standard:
 - IRC Appendix R
 - NFPA 13-D (areas exempt from sprinkler coverage are allowed)
 - NFPA 13-D Plus (sprinkler entire house except attics & crawlspaces)
 - NFPA 13-R Plus (sprinkler entire house except attics & crawlspaces)
 - NFPA 13
- Required Fire Sprinkler system design and installation shall be installed per designs standards posted at <http://www.mercergov.org/page.asp?NavID=2614>.
- ✓ TESTING: Three fire sprinkler system tests are required.
 - Hydrostatic pressure testing.
 - A functional flow test (bucket test). The city inspector will witness the testing conducted by a certified installer/tester. It is strongly recommended this test be performed prior to the cover inspection.
 - Final. The city inspector will witness the testing conducted by a certified installer/tester. All alarms must be installed and operational with monitoring (when required). Provide copies of the backflow preventer test results, head box and wrenches, and all controls properly labeled. A statement of compliance must be provided to the inspector at the final inspection; a written statement by the installing contractor attesting the fire protection system has been installed per approved plans and tested per manufacturer's specifications and appropriate standards. Any deviations from the design standards shall be noted and copies of the approvals for such deviations shall be attached to the statement.
- Fire-retardant coating shall be applied to protect all combustible concealed spaces such as attics, crawlspaces, plenums and similar spaces that are not protected by fire sprinklers. The application shall be in accordance with an approved ICC-ES Report, approved manufacturer's installation instructions, and NFPA 703 (Chapter 5 - Fire-Retardant Coatings for Building Materials) and include the following items:

- ✓ The approved fire retardant coating shall have an ICC report available. The application shall be certified by the applicator as being in conformance with the manufacturer's directions. A copy of the application certificate shall be provided to the city inspector.
- ✓ Fire-retardant coatings shall remain stable and adhere to the material under all atmospheric conditions to which the material is exposed. Fire-retardant coatings shall possess the desired degree of permanency and shall be maintained to retain the effectiveness of the treatment under the service conditions encountered in actual use. A fire-retardant coating shall not be used for outdoor installations that are not weather protected unless labeled for such installations.
- ✓ The classification of fire-retardant coatings shall apply only when the coating is applied at the rates of coverage and to the applicable substrate, building material, or species of wood indicated on the test report when the coating is applied in accordance with the manufacturer's directions supplied with the container.
- ✓ A fire-retardant coating shall not be coated over with any material unless both the fire-retardant coating and the overcoat have been tested as a system and are found to meet the requirements of a fire-retardant coating.
- ☒ A minimum thickness of 5/8" Type X Gypsum Wall Board shall be installed throughout all interior walls and ceilings.
- ☐ Solid core doors will be provided at all bedrooms, utility and laundry rooms.
- ☒ Address identification shall be plainly visible from the street fronting the property. These numbers shall be a minimum of 6 inches high with a minimum stroke width of 0.5 inch on a contrasting background. Where access is by means of a private road and the building address cannot be viewed from the street, directional signage with an indicating address shall be provided as necessary to identify the building location. For example, all forks or turn-offs of an access road leading to the final driveway shall be marked. The driveway shall be marked with the house address numerals as shall the home or building facing the entrance drive (IFC 505).
- ☒ Fire and Rescue pathways around buildings shall be provided as follows:
 - ✓ A clear path around the house shall be maintained for fire and rescue access.
 - ✓ A minimum four foot wide space around the exterior shall be maintained.
 - ✓ Grass, pavement or gravel is acceptable.
 - ✓ Fenced areas shall have gates provided at each end of the house if applicable.
- ☒ FIRE SAFETY DURING CONSTRUCTION
 - ✓ Approved fire extinguishers shall be placed throughout each floor level and clearly marked so that no travel distance shall exceed 50 feet. Fire extinguishers shall have a minimum rating of 2A10B:C and shall be tagged by a certified extinguisher company as currently serviced
 - ✓ Flammable liquids are not allowed to be used for cleaning. Flammable liquids shall be kept in approved cabinets. Motorized equipment shall not be refueled inside the building.
 - ✓ Spraying (using lacquers and flammables) is specifically prohibited inside the structure. The spraying of flammable finishes shall be accomplished in an IFC approved spray booth and the finished wood transported to the site for assembly. The contractor may use flammable lacquer finish that is applied by brush.
 - ✓ Other flammables (contact cement, glues, paints, solvents, etc.) shall be used in a well-ventilated area with no smoking signs erected and sources of potential ignition eliminated.
 - ✓ No Smoking signs shall be posted and maintained throughout the structure (especially where flammable finishes will be applied).

- ✓ Welding, cutting, brazing and other hot work shall be done with extreme care and a fire watch shall be maintained for at least 30 minutes after the hot work is completed. Fire extinguishing equipment shall be readily available while all hot work is underway.
- ✓ All temporary stairs and ramps into the structure shall be capable of supporting required loads and provided with a graspable handrail at the open side.

Planning/Zoning Requirements

1.

Trees

1. Post permit with conditions in a visible spot on site during work.
2. Designated tree/trees may be cut if:
 - Roots are undisturbed and retained for slope stability
 - Other designated vegetation is not disturbed within protected drip lines or slopes
 - An eagle management plan is required by the US Fish & Wildlife Service
 - Trees on adjacent property are protected
 - Designated tree trunks are wrapped
 - Geotechnical hold harmless agreement is signed and recorded by owner
 - Waiver to seasonal development limitation is granted
 - Tree protection fencing is installed and inspected prior to any work including demolition
 - Right of way trees are protected throughout project
 - Replacement trees are planted at least 10 feet from buildings, each other, and existing trees
 - For border trees, written permission from neighbor is obtained prior to removal
3. All tree protection fencing shall be installed before any work begins, including demolition and grading. Fencing must be maintained for the duration of the project and is subject to inspection at any time. Temporary removal of fencing requires prior approval by the city arborist.
 - Tree protection fencing must be installed at the drip line of trees to be saved or as otherwise noted on the plans
 - Do not remove tree protection fencing without authorization by city arborist
 - No driving or parking of equipment within drip line
 - No storage of construction supplies, materials, or debris within drip line
 - Steel plates or 12" of mulch required to cover roots within drip line if work is approved within drip line
 - No grading within drip line.
 - Exposed roots must be clean cut, covered with mulch and consistently irrigated
 - Removal of existing vegetation within drip line shall only occur in conjunction with final landscape installation.
 - Violation may require assessment by qualified arborist with TRAQ certification and installation of mitigation measures recommended by the arborist.
4. Change to the original scope of work requires prior approval by the city arborist.
5. Slopes exceeding 30% are subject to the October 1 – April 1 Seasonal Development Limitations described in MICC 19.10.030. No tree cutting may occur during this period unless a hazard exists.
6. Hazard Tree Assessments are the responsibility of the owner when applicable.

- 7. If tree protection is not maintained during construction or there is evidence of detrimental impact observed on any tree on site, trees may be required to be assessed by a qualified arborist with TRAQ certification hired by the applicant and appropriate mitigation measures recommended. The arborist shall determine if the trees are healthy, and whether or not they have been adversely impacted by construction activities, reducing the likelihood of survival after construction. The arborist shall provide the city arborist with a written inspection report documenting the tree assessment, findings of whether adequate tree protection was provided and identification of appropriate mitigation measures if trees were damaged. Mitigation may include pruning, watering, applying wood chips, or removal of tree if stability of tree is compromised due to construction. If the arborist determines that the tree(s) must be removed, then the tree(s) shall be replaced at a ratio up to 4:1 as determined by the city arborist. The species of the replacement trees must be approved by the city arborist.
- 8. Comply with Mercer Island Tree Protection Fencing and Tree Replanting details.
- 9. Other site specific permit conditions:

- When authorized by the city arborist, the contractor may excavate within the dripline of a tree. However, a qualified arborist (Certified Tree Risk Assessor TRAQ) must be on site during all construction activities and shall provide a written inspection report documenting their observations during construction. All large exposed roots must be evaluated in writing by the qualified arborist. Large roots are considered any roots at least two inches in diameter encountered within five times the trunk diameter (DSH) of the tree. This is to ensure that the tree(s) will not be destabilized by severing the root(s) in question.
- Additional comments:

By signing this, I acknowledge that I have read all of the above conditions and will follow them to the best of my abilities. If I have any questions on these conditions or any other part of the permit documents I will call and get clarifications prior to performing any work:

Owner/Representative: _____ Date: _____

Printed Name: _____

1
2
3
4
5
6
7
8
9
10
11
12
13
14
15
16
17
18
19

IN THE SUPERIOR COURT OF THE STATE OF WASHINGTON
IN AND FOR KING COUNTY

COREY and COURTENEAY DUBROWA,
individually and as husband and wife,

Plaintiffs,

vs.

CITY OF MERCER ISLAND, a municipal
corporation; BARCELO HOMES, INC., a
Washington corporation; and STUDIO 19
ARCHITECTS,

Defendants.

NO. 15-2-26847-3 SEA

ORDER OF DISMISSAL ON
SUMMARY JUDGMENT

(CLERK'S ACTION REQUIRED)

THIS MATTER came before the Court on Plaintiffs' Motion for Summary Judgment and Defendant City of Mercer Island's Cross Motion for Summary Judgment, with which Defendant Barcelo Homes, Inc., has joined. The Court has reviewed the records, files, and pleadings herein including:

1. Plaintiff's Complaint for Declaratory and Injunctive Relief;
2. Plaintiff's Motion for Summary Judgment;
3. Declaration of Rita Latsinova in Support of Summary Judgment Motion;
4. City of Mercer Island's Response to Plaintiff's Motion for Summary Judgment;

1
2
3
4
5
6
7
8
9
10
11
12
13
14
15
16
17
18
19

- 5. Declaration of Shana Restall in Support of Mercer Island's Response to Plaintiff's Motion for Summary Judgment;
- 6. Declaration of Christina M. Schuck in Support of Mercer Island's Response to Plaintiff's Motion for Summary Judgment;
- 7. Defendant Barcelo Homes' Joinder in Defendant City of Mercer Island's Motion for Summary Judgment;
- 8. City of Mercer Island's Motion to Dismiss Under CR 12(b)(6), converted to a Cross-Motion for Summary Judgment;
- 9. City of Mercer Island's Reply in Support of its Motion to Dismiss Under CR12(b)(6);
- 10. Order Denying Defendant Barcelo Homes, Inc.'s Motion to Dismiss and Converting Defendant City of Mercer Island's Motion Under CR 56;
- 11. Plaintiffs' Response to City of Mercer Island's Motion for Summary Judgment;
- 12. Plaintiffs' Reply in Support of Motion for Summary Judgment;
- 13. City of Mercer Island's Reply in Support of Summary Judgment;
- 14. Declaration of Shana Restall in Support of Mercer Island's Reply on Summary Judgment;
- 15. Defendant Barcelo Homes' Joinder in the City of Mercer Island's Reply in Support of its Motion for Summary Judgment;
- 16. Department of Ecology Staff Report, 2013 Rulemaking for Chapter 197-11 WAC, SEPA Rules, provided by Barcelo Homes at oral argument on February 19, 2016.
- 17. Certification of Administrative Record for Judicial Review of Land Use Decision dated February 5, 2016.
- 18. Supplemental Certification of Administrative Record dated February 23, 2016

\\
\\
\\

1
2
3
4
5
6
7
8
9
10
11
12
13
14
15
16
17
18
19

Based on the foregoing, the Court DENIES Plaintiffs' motion for summary judgment and GRANTS Defendant City of Mercer Island's motion for summary judgment for the following reasons:

FACTUAL BACKGROUND

Plaintiffs Corey and Courteneay DuBrowa challenge the City of Mercer Island (City) decision that a Barcelo Homes project next to their property is categorically exempt from State Environmental Policy Act (SEPA) review under RCW ch. 43.21C. Barcelo Homes seeks a permit to construct a 7,500 square-foot single family residence which involves the excavation over 1,600 cubic yards of soil and the removal of a significant number of large trees on the site. The DuBrowas have serious concerns regarding the scope of the excavation and tree removal. They contend that the City's exemption decision violates SEPA regulations, the Growth Management Act (GMA), and the Mercer Island City Code (MICC). The DuBrowas are particularly disturbed by the fact that the City initially determined that the project was subject to SEPA, notified neighbors of its Determination of Non-Significance (DNS) under SEPA, and then reversed itself after the DuBrowas filed an administrative appeal with the City Planning Commission. The City contends it erred in initiating a SEPA process and it cannot legally impose SEPA requirements on a categorically exempt project.

On November 3, 2015, the DuBrowas filed this petition for judicial review. They seek a declaration that the city's withdrawal of the DNS is contrary to SEPA and MICC, an order directing the City to reinstate the DNS, and an order directing the City to reinstate the DuBrowas' appeal before the Mercer Island Planning Commission.

ISSUES

The Court must answer the following issues:

- 1. Is Barcelo Homes' project categorically exempt from SEPA under WAC 197-11-305 and WAC 197-11-800(b)?

- 1 2. Even if categorically exempt, does any "critical area" exclusion apply that
2 would pull this project back into the rubric of SEPA?
- 3 3. Has the City of Mercer Island, by withdrawing the DNS, eliminated any
4 opportunity to challenge the project's environmental risks?

5 **ANALYSIS**

- 6 **1. The City of Mercer Island correctly concluded that the Barcelo Homes project
7 is categorically exempt from SEPA.**

8 Under Department of Ecology rules, WAC ch. 197-11, when a person seeks a land
9 use permit, the City must decide whether the project is "categorically exempt" from SEPA.
10 WAC 197-11-720.¹ If a categorical exemption (defined in Part Nine of WAC ch. 197-11)
11 applies, the City has no legal authority to impose SEPA requirements on the permit applicant.
12 RCW 43.21C.110(1)(a). It thus may not make a "threshold determination" that an
13 environmental impact statement is required. WAC 197-11-797; WAC 197-11-720.

14 The City admits that it conducted an evaluation of probable significant adverse
15 environmental impacts because it assumed the project was not SEPA-exempt. It also admits
16 it retracted its threshold determination of non-significance because it erred in deciding the
17 project was non-exempt. The key legal issue is whether the City correctly concluded that the
18 project is categorically exempt under WAC 197-11-305 and WAC 197-11-800.

19 Under WAC 197-11-305(1), the Barcelo Homes project is categorically exempt (a) it
20 fits within a categorical exemption set out in Ecology's SEPA rules and (b) no exception
21 applies.

22 WAC 197-11-800(1)(b) renders categorically exempt the construction of up to four
23 detached single family residential units and the excavation of any fill necessary for the
24 construction of these units. The Barcelo Homes project falls within this exemption.

25 The DuBrowas contend that this subsection (b) exemption does not apply because the
26 City has passed an ordinance with a different exemption level, as allowed by WAC 197-11-

27

28 ¹ A "categorical exemption" is an action deemed by law not to significantly affect the environment under
29 RCW 43.21C.110(1)(a). WAC 197-11-720.

1 800(c). Under WAC 197-11-800(c), a city may “raise the exempt levels up to the maximum
2 specified in (d) of this subsection by implementing ordinance or resolution.” The regulation
3 sets out a detailed and specific process by which a city may “raise the exempt levels.” *Id.*
4 The DuBrowas argue that MICC 19.07.120(J)(5) is such an ordinance and that it trumps the
5 categorical exemption in WAC 197-11-800(b). This ordinance provides in pertinent part:

6 J. Determination of Categorical Exemption.

7 1. Upon the receipt of an application for a proposal, the receiving city
8 department shall, and for city proposals, the initiating city department shall,
9 determine whether the proposal is an action potentially subject to SEPA and,
10 if so, whether it is categorically exempt. This determination shall be made
11 based on the definition of action (WAC 197-11-704), and the process for
12 determining categorical exemption (WAC 197-11-305). As required, city
13 departments shall ensure that the total proposal is considered. If there is any
14 question whether or not a proposal is exempt, then the responsible official
15 shall be consulted.

16 2. If a proposal is exempt, none of the procedural requirements of this section
17 apply to the proposal. The city shall not require completion of an
18 environmental checklist for an exempt proposal. The determination that a
19 proposal is exempt shall be final and not subject to administrative review.

5. The following types of construction shall be categorically exempt ...:

a. The construction or location of any residential structures of four or fewer
dwelling units;

d. Any landfill or excavation of 500 cubic yards or less throughout the
total lifetime of the fill or excavation ... (emphasis added).

The DuBrowas argue that while WAC 197-11-800(b)(i) and (v) exempt residential projects
regardless of the quantity of soil to be excavated, MICC 19.07.120(J)(5) renders that same
project non-exempt if the quantity of soil to be excavated is greater than 500 cubic yards.

The Court agrees with the City that MICC 19.07.120(J)(5)(d) is not an ordinance
intended by the City to “raise the exempt level” under WAC 197-11-800(c). The WAC sets

1 no quantity limit on soil excavation—it only requires that the excavation be necessary for
2 construction of four or fewer single family residential units. If MICC 19.07.120(J)(5) was
3 intended to modify the categorical exemption of WAC 197-11-800(b)(i) and (v), it would
4 actually lower the exempt soil excavation level, effectively narrowing rather than broadening
5 the categorical exemption. When state law preempts a particular field of regulation, a city
6 cannot by ordinance prohibit what state law allows. *State, Dept. of Ecology v. Wahkiahum*
7 *County*, 184 Wash. App. 372, 377, 337 P.3d 364 (2014), *review denied*, 182 Wash.2d 1023
(2015). The City has the authority to make the categorical exemption broader than the state
regulations allow, but it cannot make the exemption narrower.

8 Moreover, RCW 43.21C.135 grants to municipalities the authority to adopt
9 Department of Ecology SEPA rules by reference. MICC 19.07.120(D) provides that the City
10 adopts by reference all of SEPA rules “as adopted by the Department of Ecology ... and as
11 the same may be amended hereafter amended.” The City specifically cites to WAC 197-11-
12 800 as one of the rules it adopts by reference. Thus, the MICC creates the same categorical
13 exemption as found in WAC 197-11-800(b)(i) and (v). There is nothing in MICC
14 19.07.120(J) that indicates any intent to trump WAC 197-11-800(b) or to “raise the exempt
15 levels” set out in that WAC.

16 The Court concludes that MICC 19.07.120(J)(5) was not enacted by the City of
17 Mercer Island pursuant to the authority granted to it in WAC 197-11-800(c). MICC
18 19.07.120(J)(5) tracked the language of WAC 197-11-800 until Ecology amended the WAC
19 to clarify that the excavation categorical exemption soil limit only applies to stand-alone
excavation projects. There is nothing to suggest in this record that the City of Mercer Island
ever affirmatively chose to take advantage of the ability to deviate from the WACs. Thus, the
categorical exemption of WAC 197-11-800(b)(i) and (v) apply and the Barcelo Homes project
fits within that categorical exemption.

1 **2. The City of Mercer Island has not taken action to exclude critical areas from**
2 **SEPA's categorical exemptions.**

3 Under WAC 197-11-305(1)(a), even if a proposal fits within a specific categorical
4 SEPA exemption, the proposal may lose this exemption if it falls under WAC 197-11-908's
5 critical areas exception. WAC 197-11-908(1) provides:

6 Each county/city may select certain categorical exemptions that do not apply
7 in one or more critical areas....

8 The WAC expressly allows cities to exclude "minor new construction" projects listed in WAC
9 197-11-800(1)(b) from SEPA's categorical exemption if the projects are to be built in a
10 "critical area." If a city chooses to implement a critical area exception, SEPA requirements
11 for otherwise exempt projects would apply.

12 Under the Growth Management Act (GMA), RCW 36.70A.170(1)(d), cities must
13 take steps to designate its "critical areas." A critical area is defined as including
14 "geologically hazardous areas." RCW 36.70.030(5). Geologically hazardous areas are
15 defined as areas that, because of its susceptibility to erosion, sliding, earthquake or other
16 geological events, "are not suited to the siting of commercial, residential, or industrial
17 development." RCW 36.70A.030(9). The parties agree that both the DuBrowas' property
18 and the Barcelo Homes property fall within a geologically hazardous area.

19 RCW 36.70A.172 requires cities to develop policies and regulations to protect the
20 functions and values of these critical areas, which the City has done. MICC 19.07.010 *et*
21 *seq.* Any project proposing to alter a critical area must comply with these ordinances.
22 MICC 19.07.020(A).

23 The question presented is whether the City of Mercer Island, by enacting GMA critical
24 area ordinances, has also chosen to exclude residential developments in those areas from the
25 SEPA categorical exemption? This Court concludes it has not. The DuBrowas cite to MICC
26 19.07.020(A) that provides:

1 [A]ny alteration of a critical area or buffer shall meet the requirements of this
chapter unless an allowed alteration or reasonable use exception applies under
MICC 19.07.030.

2 The city ordinance describes what happens if a proposed project does not meet the
3 requirements of the chapter: that project must either meet the definition of an “allowed
4 alteration” or the developer must seek a “reasonable use exception” under MICC 19.07.030.
5 This provision, however, does not by its terms exclude critical area development from the
6 SEPA categorical exemption of WAC 197-811-800. A project can be legally SEPA exempt
7 and still subject to the GMA critical areas requirements under the City’s code. The Court
concludes that the City has not, by enacting critical area regulations, decided to make all such
development projects in those areas subject to SEPA.

8 **3. The City of Mercer Island, by withdrawing the DNS and rendering moot the
9 DuBrowas’ SEPA appeal, has not eliminated their opportunity to challenge the
project’s compliance with the GMA.**

10 The DuBrowas contend that the City has allowed the Barcelo Homes project to
11 proceed in violation of the City’s critical area ordinances and that they have no method by
12 which to challenge what they claim are GMA violations unless there is a SEPA administrative
hearing. This Court disagrees.

13 The legislature enacted the GMA in 1990 to address concerns related to
14 “uncoordinated and unplanned growth” in the State and “a lack of common goals
15 expressing the public’s interest in the conservation and the wise use of our lands. . . .” RCW
16 36.70A.010. The GMA provides a “framework” of goals and requirements to guide local
17 governments who have “the ultimate burden and responsibility for planning. . . .” RCW
36.70A.3201; *see also Thurston Cty. v. W. Washington Growth Mgmt. Hearings Bd.*, 164
Wash.2d 329, 336, 190 P.3d 38, 41 (2008).

18 The City has enacted MICC 19.07.060 to impose requirements on developments
19 within geologically hazardous areas. Under this ordinance, the proponent of a project must
submit a geotechnical report, which the City has required of Barcelo Homes in this case.

1 The code official must then determine if the project will adversely impact other critical
2 areas, whether it will adversely impact adjacent properties (such as the DuBrowas), and
3 whether if so, whether Barcelo Homes can mitigate these impacts. The City has not made
4 a final decision regarding whether the project meets the City's critical area site development
5 requirements. The City's attorney represented to this Court that the City's critical areas
6 assessment is on-going and that the DuBrowas' concerns regarding the removal of trees, the
7 quantity of excavation planned, and the use of a private road for construction are all issues
8 that the City will review as a part of this assessment. Even though the project is SEPA-
9 exempt, the City has not decided that the project is GMA-exempt and has not yet decided
10 what, if any, mitigation measures it might impose on Barcelo Homes to ensure that the
11 DuBrowas' property is not adversely affected.

12 The Court concludes that any alleged violation of the critical areas ordinances by the
13 City is not ripe for judicial review because the City has not rendered a final decision on what
14 development conditions it may impose in this geologic hazard area, as required by MICC
15 19.07.060. Any decision the City makes under MICC 19.07.040 and 19.07.060 are subject to
16 appeal processes set out in MICC 19.15.010(E) and 19.15.020(J). *See* MICC 19.07.040(E).
17 The City's decision to withdraw the DNS and render moot the DuBrowas' SEPA appeal has
18 not eliminated their opportunity to challenge the project's compliance with city critical areas
19 ordinances.

20 The Court understands the concerns the DuBrowas have regarding the Barcelo Homes
21 proposed project. They are quite reasonably frightened by what they perceive as a serious
22 risk to their home, their access road, and the environment surrounding their property. While
23 the Court is constrained by the law and thus must conclude that the project is SEPA-exempt,
24 the Court is not finding that the Barcelo Homes project, as currently proposed, is appropriate
25 for a geologically hazardous area. Under the law, this assessment must be made in the first
26 instance by the City's code official.

1 For these reasons, the DuBrowas' motion for summary judgment is DENIED. The
2 City of Mercer Island's motion for summary judgment is GRANTED. This case is dismissed.

3 Dated this 24th day of February, 2016.

4 *Electronic signature attached*

5 _____
6 Judge Beth Andrus
7
8
9
10
11
12
13
14
15
16
17
18
19

King County Superior Court
Judicial Electronic Signature Page

Case Number: 15-2-26847-3
Case Title: DUBROWA ET ANO VS MERCER ISLAND CITY OF ET AL

Document Title: ORDER SUMMARY JUDGMENT

Signed by: Beth Andrus
Date: 2/24/2016 10:36:49 AM

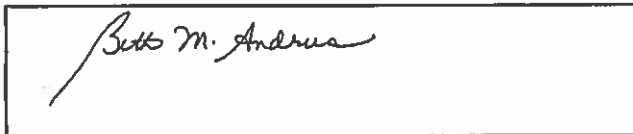

Judge/Commissioner: Beth Andrus

This document is signed in accordance with the provisions in GR 30.

Certificate Hash: D92F76D12132FF531AF16720A721F097AC7A50B6
Certificate effective date: 7/29/2013 12:26:48 PM
Certificate expiry date: 7/29/2018 12:26:48 PM
Certificate Issued by: C=US, E=kcscefiling@kingcounty.gov, OU=KCDJA,
O=KCDJA, CN="Beth
Andrus:dE53Hnr44hGmww04YYhwmw=="

Page 11 of 11

LAW OFFICES OF
SORENSEN & EDWARDS, P.S.

701 FIFTH AVENUE, SUITE 3300
SEATTLE, WASHINGTON 98104

Michael R. Sorensen
Member, Washington Bar
DIRECT LINE (206)-224-8224

FACSIMILE (206) 682-7100

Bruce N. Edwards
Member, Washington & Alaska Bars
DIRECT LINE (206)-224-8225

December 14, 2017

VIA HAND DELIVERY
AND ELECTRONIC MAIL

Robin Proebsting, Senior Planner
Development Services Group
City of Mercer Island
9611 SE 36th Street
Mercer Island, WA 98040

Re: Further Comments Upon Request for Approval of A Critical Area Determination In
Order to Modify A Steep Slope, Associated with Construction of a New Single Family
Residence

DSG File #: CA017-007
Applicant/Owner: Paul Maksimchuk/Four Seasons Homes LLC
Location of Property: 4634 E. Mercer Way, Mercer Island, WA 98040
King County Tax Parcel: 75587008
Building Permit #: 1507-166REV

Dear Senior Planner Proebsting:

I am writing you to update my comments submitted October 10, 2017 relative to the pending application (the "Application") by Paul Maksimchuk/Four Seasons Homes LLC ("Applicants") to receive a favorable Critical Area Determination that will permit modification of a steep slope. I reside, along with my family, at 4634 East Mercer Way, and the only access that I and my family have to East Mercer Way is via the same narrow access road that the owners of 4634 East Mercer Way will use to bring and remove heavy equipment and trucks to and from that property. As you may further recall, the subject property (4634 East Mercer Way) as well as the surrounding area and our access roadway all lie in a "geologic hazard area" within the meaning Mercer Island City Code ("MICC") 19.07060.A.

I understand that you and other members of the City's Development Services Group are presently in the process of evaluating the Application, and I am providing these additional comments to aid you in your evaluation efforts. As before, I make these comments on my own behalf (and that of my family) and not as the legal representative of any of our neighbors.

As you may know, there were a series of leaks that occurred over the past few days in the mainline water utility on Mercer Island. The City's Department of Public Works responded to these leaks and undoubtedly has additional information that can be provided to you in addition to the information I set forth below.

One of these leaks occurred on the late afternoon / early evening of Sunday, December 10 and was beneath the street on 46th Street S.E. This street slopes towards the east and is located immediately above the 4600 block of East Mercer Way. Although the leak only lasted for only a relatively brief period, a significant volume of water escaped and ran downhill underneath 46th Street S.E. until it emerged out a supporting soil bank at the top of a gully that begins immediately below the "T" intersection of 46th Street SE and Dawn Drive. Once the water emerged from the soil bank, it ran down the gully to East Mercer Way, across East Mercer Way, depositing substantial sediment, mud and debris along the way including on East Mercer Way itself, and then back into the lower gully that lies east of (and below) East Mercer Way. This lower gully is the same gully that lies adjacent to the access roadway into our neighborhood. So much sediment was carried downhill in the process that the surface drains at both the top and the mouth of the lower gully were blocked. Blockage of the top drain caused the water to run down the access roadway itself. The blockage of the lower drain threatened to flood one of the homes below the gully, until my son and I physically cleared the lower surface drain of mud and debris that same evening.

Accompanying this letter are four photographs that show you the extent of the damage caused by the water leak underneath 46th Street S.E., which I ask that you place (along with this letter) into the record for DSG File # CA017-007 and Building Permit 1507-166REV. These four photographs were all taken at approximately 10:00 a.m. on Monday, December 11, 2017 (the morning after the leak) occurred and are numbered 1 – 4 as follows:

Photograph #1 was taken looking south on the eastern shoulder of Dawn Drive, and shows the significant erosion that occurred to the soil bank supporting Dawn Drive at the point where the escaping water emerged from underneath 46th Street S.E. Substantial backfilling bank stabilization will have to occur at this point if Dawn Dive is to be adequately supported and not pose a safety hazard.

Photograph #2 was taken looking west part of the way up the upper gully that lies between Dawn Drive on the west (top) and East Mercer Way on the east (bottom). This photograph shows the substantial volume of sediment, mud and debris that were carried downhill from the soil bank supporting Dawn Dive and from the upper gully itself. To give an idea of the scale of the photograph, if you look closely just above the center of the photograph you can see my son, Alex, who is six feet tall. At the point where he is standing, he is still a

substantial way down the gulley's slope from Dawn Drive and the eroded supporting soil bank.

Photograph #3 shows just a portion of the sediment, mud and debris from the soil bank and the upper gulley itself that were deposited in the residential yard at the base of the upper gulley. Additional mud, sediment and debris were carried by the force of the water through this residential yard and onto East Mercer Way and into the lower gulley, blocking drains that lie at the top and the bottom of the lower gulley.

Photograph #4 was taken looking east from the top of the upper gulley at Dawn Drive towards East Mercer Way. East Mercer Way is visible in the upper right hand corner. This photograph shows the substantial erosion of the soil bank that supports Dawn Drive as well as erosion down the upper gulley itself. The wet-appearing areas that are in the right center of the upper third of the photograph are the sediment, mud, and debris that were deposited in the residential yard at the base of the upper gulley. These wet-appearing areas are the same as the area shown in Photograph #3 above.

At the risk of understatement, I believe that the water leak on 46th Street S.E. demonstrates how relatively easily it is for a water leak to happen with substantial resulting damage. As far as I know, there was no single catastrophic event that caused the 46th Street S.E. break; apparently the break was apparently caused by unstable soils that shifted slightly as the air temperature warmed and cooled last weekend. The City's water piping is old, and apparently, is quite susceptible of damage from a variety of different causes.

With regard to the Application DSG File # CA017-007 for a favorable Critical Area Determination to Permit Grading at 4634 East Mercer Way, our prior comments highlight the presence of a City-owned main water line underneath the narrow access roadway that allows our neighborhood (including the subject property at 4634 East Mercer Way) to access East Mercer Way. There is a fire hydrant that is fed by this main water line located approximately 100 feet down the access roadway and east of East Mercer Way.

Given that the 46th Street S.E. break apparently occurred simply because the soils underneath 46th Street S.E. shifted slightly due to changes in the ambient air temperature, it is no stretch to envision that a similar break could result from soil shifting due to repeatedly running heavy machinery and trucks up and down the access roadway. My prior submission (along with those of my neighbors) underscored that the surface of the access roadway over the water line into our neighborhood is very thin and without a proper subsurface for support. It also is no stretch to anticipate that if a main line water leak occurs, that the escaping water will escape through the soil bank adjacent to the access roadway, run down the hillside into the lower gulley and erode the hillside in the same manner as did the water from the leak in 46th Street SE as

Robin Proebsting, Senior Planner
Development Services Group
City of Mercer Island
December 14, 2017
Page 4

shown in the accompanying photographs. The result is that this erosion will likely undermine our access roadway itself, rendering it impassable and creating an emergency situation for all in our neighborhood.

Such a situation is entirely preventable and I again ask that the City take the steps necessary to protect our neighborhood by preventing such an occurrence. I believe the MICC provides City's Development Services Group with adequate tools to do so. The lower gulley and related slopes adjacent to the 4600 block of East Mercer Way have already been determined to be a geologic hazard area with the access roadway running through it. The roadway is the only way to access 4634 East Mercer Way from East Mercer Way, and therefore, the lower gulley and access roadway are as much a part of the 4634 project area as 4634 East Mercer Way itself.

As my comment letter of October 10 indicates I concur and support with the view of our neighbors that an unfavorable Critical Area Determination should be issued as to Applicant's proposed modification of the steep slope at 4634 East Mercer Way. I also concur with and support the view of my neighbors that Building Permit 1507-166REV should be cancelled. Failing that, as an alternative I request that the Development Services Group (i) treat the lower gulley and slopes adjacent to East Mercer Way in the 4600 block and the access roadway that runs through it as a part of the 4634 East Mercer Way project area and (ii) issue appropriate orders, as described in my October 10 letter, under the City's authority relative to geologic hazard areas.

Conclusion

I respectfully request that the City proceed as set forth above and in my letter of October 10, 2017. I hereby renew my request for a copy of the City's decision relative to Applicant's request for a Critical Area Determination that permits modification of a steep slope. Also, to the extent that the City decides to receive testimony upon the Application, I hereby ask for an opportunity to testify in person. Finally, to the extent that the City desires additional materials beyond those I have submitted, please let me know so I can provide them.

Sincerely,

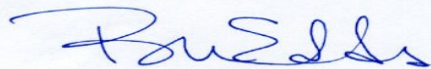

Bruce N. Edwards









June 1, 2018

City of Mercer Island
Development Services Group
9611 SE 36th Street
Mercer Island, Washington 98040

Attn: Ms. Robin Proebsting, Senior Planner

Transmitted via email to: *robin.proebsting@mercergov.org, mpetri@copiersnw, and rita.latsinova@stoel.com*

**Re: Additional Review Comments
Proposed Single-Family Residence Development
4634 East Mercer Way, Mercer Island, Washington
City of Mercer Island Permit No. 1507-166**

Dear Ms. Proebsting:

This letter provides an update to comments presented in my October 10 and December 27, 2017 letters regarding the proposed development at 4634 East Mercer Way in Mercer Island, Washington.

I understand that the City of Mercer Island (City) sent a letter dated October 26, 2017 to the applicant requesting additional analyses regarding potential impacts to the shared access roadway due to construction traffic and proposed work in the water course along the south side of the property. The applicant submitted the following information in response to the City's October 26, 2017 request:

- Revised Plan Set dated May, 8, 2018
- A letter titled "*Response to Comments; Proposed Single-Family Residence; 4634 East Mercer Way, Mercer Island, Washington*" prepared by PanGeo and dated May 2, 2018
- A letter titled "*Response to CAO-0017 (Critical Area Determination for 4634 East Mercer Way)*" prepared by Studio 19 Architects and dated May 3, 2018.

In addition to reviewing these items, I completed a site visit on May 21, 2018 to observe current conditions along the shared access roadway and the watercourse along the south side of the Petrie property.

In my October 10, 2017 letter, I had expressed concerns regarding impacts to the stability of the slopes supporting the shared access roadway due to construction truck traffic during construction of the proposed residence at 4634 East Mercer Way. In my December 27, 2017 letter, I expressed additional concerns regarding potential impacts to the waterline situated within the shared access roadway due to construction truck traffic. Failure of the waterline within the shared access roadway will have similar consequences as the recent (winter 2017) waterline failure near the intersection of

46th Street SE and Dawn Drive. If the waterline in the shared access roadway were to fail, failure would result in significant impacts to the area, including flooding, property damage, and mud and debris flowing into Lake Washington. The applicant's submissions do not address any of the concerns related to the potential impacts to the waterline.

Regarding the stability of the slope, to limit adverse impacts as a result of construction, the Applicant's geotechnical engineer, PanGeo, proposes that 5-yard dump trucks be used to haul excavated soil from the site. PanGeo states that:

"...the reduced truck load may potentially cause minor additional roadway subgrade creep and pavement cracks or enlarges existing cracks. However, it is our opinion that the anticipated truck traffic with reduced truck load will not likely have adverse impacts on the stability of the roadway and slopes along the road."

PanGeo does not provide any engineering analysis to support the above conclusion and opinions. Also, it is not clear if PanGeo proposes that the applicant also limit the weight of other heavy vehicles, such as concrete trucks, logging trucks, cranes, etc., during construction.

I disagree with PanGeo's assessment limiting impacts by using 5-yard dump trucks. Using 5-yard dump trucks to haul excavated soil from the site will essentially double the number of truck trips. Increasing the number of truck trips will likely have significant impacts to the roadway subgrade and stability of the slopes along the roadway and to ingress and egress of the residents living along the roadway. Though the total weight of the truck is decreased by using a 5-yard dump truck, the tire pressure of the 5-yard dump truck is basically the same as a standard 10-yard dump truck, which is typically around 100 pounds per square inch (psi). For comparison, a typical car/light-duty truck has a tire pressure of around 30 to 35 psi. It is the load applied by the tire that causes damage pavement and the supporting subgrade. With the pavement and subgrade subjected to twice the number of high tire loads (100 psi), it is my professional opinion that at least as much or more damage to the pavement and subgrade will occur due to the increased number of truck trips.

Similarly, if the weight of the trucks hauling excavated soil is decreased, the number of load applications to the steep slopes along the shared access road will increase due to twice the number of truck trips. Also, the slopes will be subjected to more vibration due to the increased truck trips. The increased load applications and amount of vibration will likely result in accelerated soil creep/road subsidence. Also, other heavy vehicles, such as concrete trucks, logging trucks, cranes, etc. will continue to use the shared access road during construction. These vehicles will likely further damage the pavement and subgrade and adversely impact slope stability.

In my professional opinion, using 5-yard dump trucks will not decrease the potential of damage to the pavement and roadway subgrade and reduce the potential of a slope failure involving the access roadway and represents a potential public safety hazard. Similarly, it is my professional opinion that

increasing the number of truck trips increases the potential for damaging/failure of the waterline within the shared access road.

PanGeo offers no engineering analysis for its opinion. I note that even though PanGeo states (without support) that adverse impacts to the roadway and slope are unlikely, it must believe that there is a reasonable chance that adverse impacts will occur. To address this probability PanGeo provides a vague recommendation that the roadway and slopes be monitored during construction. Yet, PanGeo provides no details regarding the monitoring plan such as who is responsible for the monitoring, frequency of monitoring, what are the thresholds values (lateral/vertical movement, settlement, etc.) for action, action items should a threshold be exceeded, etc.

I also disagree with PanGeo's opinion that construction will not impact the wood wall on the Petrie property. Tracked excavators and other large earthmoving equipment can produce high levels of vibration which will likely damage the fragile wood wall on the Petrie property. PanGeo must believe there is a reasonable probability of adverse impacts to the wood wall since it recommended monitoring. As discussed above, no details for the monitoring plan are provided.

The May 3, 2018 letter submitted by Studio 19 Architects proposes to pipe stormwater from the proposed development through the watercourse along the south side of the Petrie property and discharge the stormwater 10 feet behind the bulkhead on the Petrie property. The letter provides no evaluation of potential impacts to the watercourse by installing the pipe or from discharging stormwater behind the bulkhead. I observed that the area of the proposed discharge is relatively flat and has poor drainage. According to the Petries, the area of the proposed discharge is prone to flooding due to stormwater runoff from the watercourse. The applicant's proposal does not address these conditions and is wholly deficient.

The applicant's response is also deficient in that it does not address several comments presented in my October 10, 2017 letter. They include:

- The adequacy of the temporary erosion control facilities to fully contain stormwater runoff and sediment on the site during construction.
- Adequate control of stormwater runoff from the steep driveway.
- Impacts to the watercourse due to removal of many significant trees and the increase in impervious area.

Finally, during my May 21, 2018 site visit, I observed that the existing cracks in portion of the shared access road between East Mercer Way and the upper hairpin turn and the portion of the shared access road between the two hairpin turns have widened and deepened since my last visit in December 2017. This is indicative on ongoing creep of the soil on the steep slopes along the shared access road.

For the reasons stated in my earlier letters and here, I stand by my opinion that construction of the proposed single family residence at 4634 East Mercer Way in Mercer Island, Washington as currently planned will adversely impact critical areas on adjacent properties, thereby jeopardizing both public safety and property. Therefore, the project should not be allowed per Section 19.07.060.D.1 of the Mercer Island City Code.

If you should have any questions or require clarification on any of the items discussed above, please contact me at (206) 390-8742 or by email at ejheavey@comcast.net.

Sincerely,



Edward J. Heavey, P.E.
Geotechnical Engineer

EJH/ejh

[G:\BARCELO\COMMENT LTR\ADDITIONAL COMMENT LTR060118.DOCX]

Cc: Ms. Rita V. Latsinova,
Stoel Rives LLP
600 University Street, Suite 3600
Seattle, Washington 98101

Mr. Mark Petrie
4640 East Mercer Way
Mercer Island, Washington 98040

City of Mercer Island
Development Services Group
Mercer Island, WA 98040

Re: Deny CA017-007 Request to Alter a Steep Slope

To Who this concerns at DSG:

I respectfully ask that the request CA017-007 (Request to Alter Critical Area/Steep Slope) is denied. Available scientific data shows that this property is not appropriate for development due to the grade of the slope, documented seismic and landslide events, water runoff, and erosion issues. In addition, I ask that the comment period for this request be extended: the City website incorrectly listed the email address for DSG and therefore emails to DSG were being bounced back by the city's email server (see attachment A). Also, the signage publicizing the request was incomplete: it did not list the end date for public comment (see Attachment B).

- Multiple landslides have been documented in this area. Given the historical data, it is reasonable to expect landslides will occur in the future. These slides put both people's lives and property at risk.
(<http://www.mercergov.org/files/LandslideHazard2009.pdf>).
- Several springs are within close proximity, and one in particular that is above the area in question.
(<http://www.mercergov.org/files/LandslideHazard2009.pdf>).
- Current mature and dense forest and ground vegetation performs a critical stabilizing function by absorbing runoff and spring water, as well as preventing erosion, and reducing pollution by slowing the water as it percolates through this area. Development and machinery used in this area will destabilize the slope.
- This area had documented seismic activity during the 2001 Nisqually Earthquake. Given the known seismic risk, additional development in this area would put more people at risk when the next earthquake occurs.



-
- Development on this steep slope jeopardizes the stability of neighboring properties.
- Increasing hardscape will exacerbate the issues of erosion, by increasing runoff rates in the surrounding areas thereby destabilize surrounding properties and increasing pollution to the lake.

Steep slope protections are in place specifically to protect the people that live in and around these areas, property rights of surrounding neighbors, water quality of the lake, critical habitat and the shoreline below. Given the known hazards in this area, which were identified by the best science we have, approval of this request seems irresponsible. Current code restrictions have widely been recognized as inadequate in protecting and maintaining the critical areas on Mercer Island. This is precisely why the City Council intends to revisit this important issue in the coming months (imminently). In addition, new tree and residential building code – which IS based on best on best available science - is now in place that would likely change the tree retention standards, noxious weed requirements, and buildability of this lot. This is one of the most unstable areas of Mercer Island. I respectfully ask that this request be denied.

Sincerely,

Janice Nice

Attachment A:

Development Services: Building & Planning
206.275.7605 Fax: 206.275.7726

epermittechepermittech@mercergov.org

☆ Patrick Yamashita

RE: Undeliverable: Comment in response to CA017-007 Request to Alter a Steep Slope

To: Janice Nice

Oh, I'm so sorry. I think I was incorrect then. Can you provide me with a link to the specific webpage you were on and I'll get it corrected. My apologies.

Patrick

From: Janice Nice [<mailto:janice.imrich@gmail.com>]

Sent: Wednesday, October 11, 2017 2:03 PM

To: Patrick Yamashita <Patrick.Yamashita@mercergov.org>

Subject: Fwd: Undeliverable: Comment in response to CA017-007 Request to Alter a Steep Slope

I received this error message when the email was sent to the address listed on the website.

Begin forwarded message:

From: <postmaster@mercergov.org>

Subject: Undeliverable: Comment in response to CA017-007 Request to Alter a Steep Slope

Date: October 11, 2017 at 12:21:03 PM PDT

To: <janice.imrich@gmail.com>



Your message to epermittechepermittech@mercergov.org couldn't be delivered.

[epermittechepermittech](mailto:epermittechepermittech@mercergov.org) wasn't found at
mercergov.org.

Action Required

Unknown To address

How to Fix It

The address may be misspelled or may not exist. Try one or more of the following:

- Send the message again following these steps: In Outlook, open this non-delivery report (NDR) and choose **Send Again** from the Report ribbon. In Outlook on the web, select this NDR, then select the link "**To send this message again, click here.**" Then delete and retype the entire recipient address. If prompted with an Auto-Complete List suggestion don't select it. After typing the complete address, click **Send**.
- Contact the recipient (by phone, for example) to check that the address exists and is correct.
- The recipient may have set up email forwarding to an incorrect address. Ask them to check that any forwarding they've set up is working correctly.
- Clear the recipient Auto-Complete List in Outlook or Outlook on the web by following the steps in this article: [Fix email delivery issues for error code 5.1.10 in Office 365](#), and then send the message again. Retype the entire recipient address before selecting **Send**.

If the problem continues, forward this message to your email admin. If you're an email admin, refer to the **More Info for Email Admins** section below.

Was this helpful? [Send feedback to Microsoft.](#)

More Info for Email Admins

Attachment B: Public Comment Period is not included on the signage:

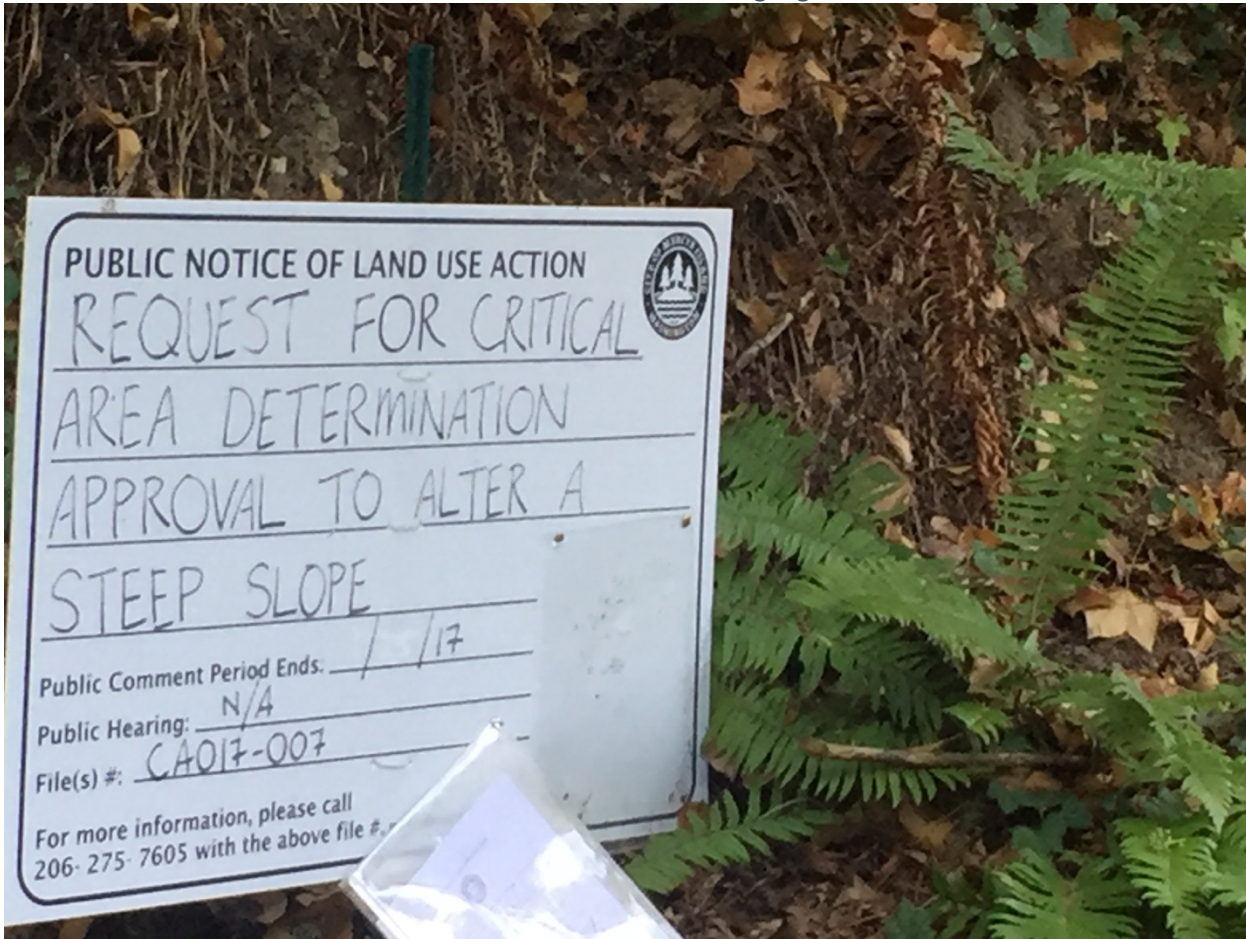

Attachment C: Available Science

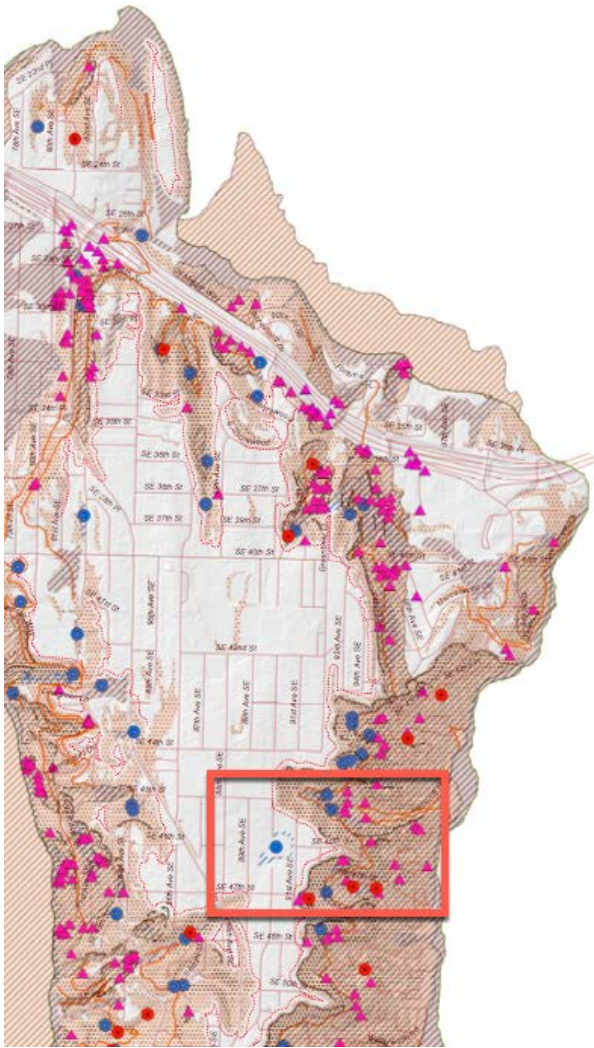

- i. Areas of historic failure or that have been documented on published maps; *See mapped known landslides below;*
- ii. Slopes steeper than 15%, intersecting a geologic contact of relatively permeable deposits over relatively impermeable deposits, and with springs or groundwater seepage; *See mapped potential slide areas below;*
- iii. Areas that have shown movement during the Holocene epoch (last 10,000 years) or which are covered by Holocene-age mass wasting deposits; *See mapped known landslides below;*
- iv. Slopes parallel or sub-parallel to planes of weakness (such as bedding planes, joint systems, and fault planes) in subsurface materials; *None identified on map, but may be locally present;*
- v. Slopes having gradients steeper than 80% subject to rockfall during seismic shaking; *See slope classification below;*
- vi. Areas potentially unstable as a result of rapid stream incision, stream bank erosion, and undercutting by wave action; *See mapped erosion locations below;*
- vii. Areas that show evidence of, or are at risk from snow avalanche; *None identified on Mercer Island;*
- viii. Areas located in a canyon or on an active alluvial fan, presently or potentially subject to inundation by debris flows or catastrophic flooding; *None identified on Mercer Island;*
- ix. Any area with a slope of 40% or steeper and with a vertical relief of ten or more feet except where composed of consolidated rock; *See slope classification below.*

Landslide hazard areas include the following mapped areas:

- Landslide Hazard**
 - Landslide Hazard Area (Known or Suspect)
 - Landslide Hazard Assessment Setback

For all other areas hazard is unknown or unquantified

Supplemental Data

- Known Landslides (I,iii)**
 - Identified Landslide Location
 - Scarp
 - Landslide and Mass Wasting Deposits; subaerial and subaqueous
- Slope (v) Class (ix)**
 - Slope 80% and higher
 - Slope 40-79%
 - Slope 15% and higher, and
- Potential Slide Area (ii)**
 - Geologic contact of coarse-grained deposits over fine-grained deposits where slope >= 15%, and
 - Area where water less than 10 feet below ground surface based on limited data set (other areas of shallow water present), or
 - Spring Locations, or
 - Spring lines.
- Areas of Rapid Stream Incision (vi)**
 - Areas of moderate to rapid stream incision/erosion; may result in unstable slopes and/or stream banks

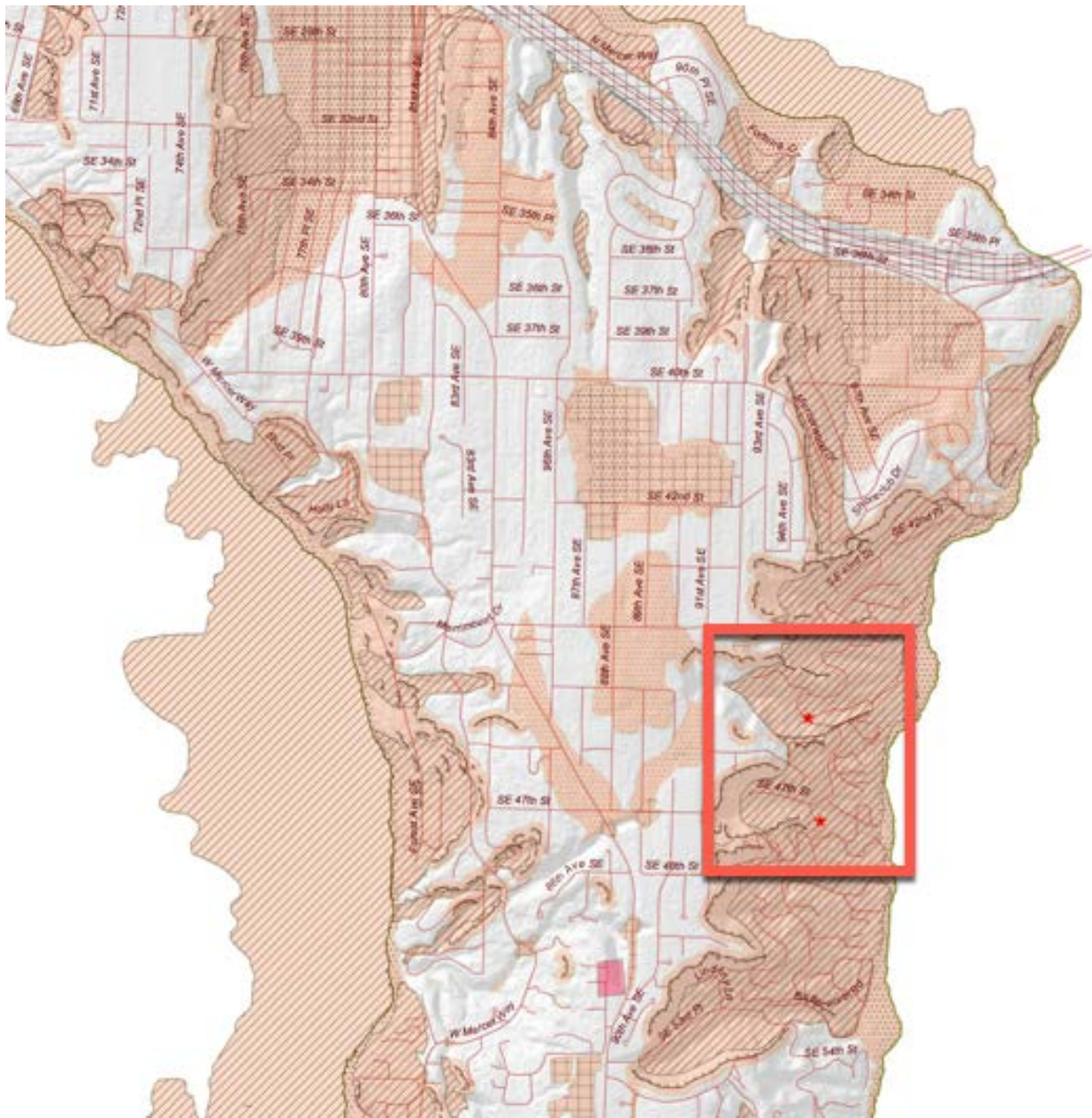

October 10, 2017

Mr. Mark Petrie
4640 East Mercer Way
Mercer Island, Washington 98040

Transmitted via email to: *mpetri@copiersnw* and *rita.latsinova@stoel.com*

**Re: Geotechnical Review
Proposed Single-Family Residence Development
4634 East Mercer Way, Mercer Island, Washington
City of Mercer Island Permit No. 1507-166**

Dear Mr. Petrie:

At your request, I have reviewed the documents pertaining to the proposed development at 4634 East Mercer Way in Mercer Island, Washington. Documents reviewed were submitted in support of City of Mercer Island (City) Permit No. 1507-166 which was initially approved by the City on August 23, 2016, but is currently under additional review by the City. The proposed project consists of constructing a single-family residence (SFR) on a heavily-treed, vacant lot located at 4634 East Mercer Way in Mercer Island, Washington (subject property). My comments are based on review of the following documents:

- *Watercourse Determination Report for 4634 East Mercer Way (King County Parcel 7558700008), Located in the City of Mercer Island, Washington, dated August 15, 2017, prepared by Wetland Resources, Inc.*
- *Geotechnical Report Addendum; Evaluation of Surcharge Load on Soldier Pile Wall; Proposed Development; 4634 E Mercer Way, Mercer Island, WA, dated August 12, 2016, prepared for Barcelo Homes, LLC by PanGeo*
- *Statement of Risk; Proposed Development; 4634 E Mercer Way, Mercer Island, WA, dated July 19, 2016, prepared for Barcelo Homes, LLC by PanGeo*
- *Response to Correction Notice #5, dated July 18, 2016, prepared by Andrew Wisdom of Studio 19 Architects*
- Approved Building Permit Submittal Drawings, including City of Mercer Island Cover Sheet dated August 23, 2016:
 - *Sheets G0.01 and G0.02, prepared by Studio 19 Architects*
 - *Site Survey: Sheets 1 and 2, prepared by APS Surveying and Mapping*
 - *Civil Drawings: Sheets C1 through C6, prepared by Litchfield Engineering*
 - *Architectural Drawings: Sheets A1.01 through A9.04, prepared by Studio 19 Architects.*
 - *Structural Drawings: Sheets S1 through S-10, prepared by Tecinstruct LLC*

In addition, I have made several visits to the area to observe conditions as they relate to the proposed development.

GEOLOGIC HAZARD AREAS

Mercer Island City Code (MICC) identifies the site of the proposed development as within a geologic hazard area. Geologic hazard areas are susceptible to erosion, sliding, earthquake, or other geological events. Because of their hazardous conditions, these areas pose a threat to health and safety when development is sited too closely. Geologic hazard areas are regulated mainly for these safety reasons, but they are also regulated for their habitat values. Steep slopes can be conduits for groundwater draining from hillsides to form the headwaters of wetland and streams.

Per section 19.07.060.D.1 of the MIMC, alterations of geologic hazard areas may occur if the code official concludes that such alterations:

- a) Will not adversely impact other critical areas;
- b) Will not adversely impact (e.g., landslides, earth movement, increase surface water flows, etc.) the subject property or adjacent properties;
- c) Will mitigate impacts to the geologic hazard area consistent with best available science to the maximum extent reasonably possible such that the site is determined to be safe; and
- d) Include the landscaping of all disturbed areas outside of building footprints and installation of all impervious surfaces prior to final inspection.

The City of Mercer Island public map portal

(<https://pubmaps.mercergov.org/SilverlightViewerEssential/Viewer.html?Viewer=ExternalWebGIS>)

shows that the shared community access roadway and the area surrounding the proposed development are located within erosion and landslide hazard areas and are critical areas as defined by MICC 19.16.010. Therefore, construction of the SFR at 4634 East Mercer Way in Mercer Island, Washington cannot adversely impact other critical areas and the surrounding properties.

COMMENTS

Based on my own review of the available documents submitted by the applicant and conditions observed during my several visits to the area, likely adverse impacts to the critical areas surrounding the proposed development include:

- At the top of one of the lower hairpin turn, the shared access road is constricted by a significant, large fir tree on one side and a rockery along the other side. The road width is only 14 ft at this location. It will be difficult for large construction trucks (dump trucks, logging trucks, and cement trucks) to make this turn along with concrete trucks and other large trucks. In my professional opinion, there is the potential for significant damage to the tree and/or rockery.

- Between East Mercer Way and the upper hairpin turn, the slope along the north side of shared access road descends steeply downward. I observed several indications of instability of the slope along this portion of the roadway. Several trees along the top of the roadway were observed to lean backwards, the fire hydrant is leaning outward, and two areas along the north edge of the shared access road have subsided and have several cracks parallel to the slope face. Slope instability is likely a result of creep of the surficial soil on the slope below the roadway. Soil creep generally occurs on slopes steeper than 50 percent and is defined as a slow, downslope movement of the surficial soil as a result of gravity. Observations made during a September 24, 2017 site visit indicated that the roadway has continued to subside in these two areas and the cracks have widened since my first visit in October 2015. Between the two hairpin turns, a steep slope supported by a series of landscape retaining walls is present along the eastern side of the shared access road. Several large cracks in the pavement that parallel the slope face were observed there, as well. The cracking is likely due to deflection of the landscape retaining walls and soil creep. The slopes supporting these portions of the shared access roadway are at risk of not being able to support the expected construction truck traffic. The project geotechnical engineer should have evaluated the impact of trucks on the stability of the slopes along the access roadway. In my professional opinion, the truck traffic will likely increase the potential of a slope failure involving the access roadway and represents a potential public safety hazard.
- The T.E.S.C. Plan (Sheet C4) calls for the temporary construction access roadway to be constructed of quarry spalls. Though required by Note 4 of the approved T.E.S.C. Plan, no measures are shown to prevent and/or capture runoff and sediment from the construction access road before reaching the shared access roadway. Note 2 of the T.E.S.C. only requires sweeping of the shared access roadway to remove sediment from the shared access roadway at the end of the day. Even if earthwork will likely occur between April and October of 2017, significant precipitation events can occur in the spring and summer months and uncontrolled runoff from temporary construction access roadway can adversely impact the residences down gradient from the subject property. Section 19.07.060.D.1.b of the MIMC does not allow for increased runoff from geologic hazard areas to prevent impacts to the subject property or adjacent properties. In my professional opinion, the TESC Plan contains inappropriate erosion control measures for the temporary access road, jeopardizing the down gradient property owners.
- All runoff from the shared access road downslope of the lower hairpin turn is collected by a trench drain across the driveway to the residence located at 4632 East Mercer Island Way. The trench drain may discharge directly to Lake Washington. Without adequate erosion control measures, sediment from the construction site may reach the lake. In my professional opinion, there are inappropriate erosion control measures for the temporary access road, exposing Lake Washington to construction stormwater and sediment flows.
- Sheet 3 of the Civil Drawings shows that the lower portion of the driveway is sloped in excess of 20 percent. A single catch basin is shown at the base of the driveway. In my professional opinion, during periods of intense precipitation, stormwater runoff from the driveway will likely over shoot the catch basin and flow down the shared access road. Section 1.07.060.D.1.b of the City of Mercer island Code does not allow for increased runoff from geologic hazard areas. In my professional opinion, there is insufficient analysis and design of

the stormwater collection system of the driveway, impermissibly exposing the geologic hazard area to increased runoff.

- A wood wall up to about 4½ ft in height is located about 15 to 20 ft east of the east property line. The wall supports a portion of the steep slope along the western edge of the paved parking area of the residence located at 4640 East Mercer Way. The slope rises about 13 ft vertical above the wall with an average slope of about 80 percent. The wall was observed to be in very poor condition. Given the fragility of the wall, it is my professional opinion that there is a potential for construction related vibration to damage the wall resulting in impacts to the property located at 4640 East Mercer Way.
- The August 15, 2017 wetland report requires a 35 ft setback from the watercourse located along the eastern side of the property. As shown on Watercourse Determination Map provided with the report, the southern edge of the proposed residence is along the edge 35 ft buffer, and the project drawings (Sheets 3, A1.01, and A1.02) show improvements within the proposed 35 ft buffet.
- The construction drawings indicate that the watercourse on the south side of the property will be directed into the storm drain outfall pipe that extends down to Lake Washington. Section 19.07.070.D.2 of the MIMC does not allow for Type 3 watercourses to be put into culverts, unless approved by the City of Mercer Island. When culverts are allowed, the MIMC requires that the culvert be designed to mitigate impacts to critical area functions. The outfall pipe has not been designed to mitigate impacts to the function of critical areas and the August 15, 2017 wetland report does not provide any analysis of potential impacts to the watercourse as a result of placing it into a pipe.
- With the removal of many significant trees and the increase in impervious area, the proposed development will significant change the site hydrology which will likely adversely impact the watercourse along the south side of the property. The August 15, 2017 wetland report does not provide any analysis of potential impacts to the watercourse as a result of the development.

STATEMENT OF RISK

Per section 19.07.060.D.2 of the MICC, alteration within geologic hazard areas may occur if the development conditions listed section 19.07.060.D.1 of the MIMC are satisfied **and** the geotechnical professional provides a statement of risk with supporting documentation indicating that one of the following conditions can be met:

Statement of Risk. Alteration within geologic hazard areas may occur if the development conditions listed above are satisfied **and** the geotechnical professional provides a statement of risk **with supporting documentation** indicating that one of the following conditions can be met:

- a) The geologic hazard area will be modified, or the development has been designed so that the risk to the lot and adjacent property is eliminated or mitigated such that the site is determined to be safe;
- b) Construction practices are proposed for the alteration that would render the development as safe as if it were not located in a geologic hazard area;
- c) The alteration is so minor as not to pose a threat to the public health, safety and welfare; or
- d) An evaluation of site specific subsurface conditions demonstrates that the proposed development is not located in a geologic hazard area.

MICC 19.07.060.D.2 (emphasis added).

The following specific comments are provided regarding the July 19, 2016 Statement of Risk prepared by PanGeo:

- The Statement of Risk provides no supporting documentation that the requirements of section 19.07.060.D.2 have been met.
- The Statement of Risk states that *“The overall site stability will be greatly improved for the post-construction condition after soldier pile walls are constructed.”* Section E on Sheet S10 of the Structural Drawings shows a temporary excavation in front of the soldier pile wall along the west side of the house to accommodate construction of the basement foundation. The excavation appears to be about 12 ft deep and sloped at about a 1 horizontal to 1 vertical inclination. The detail indicates that the excavation is to be backfilled after construction of the basement wall, leaving a level surface in front of the soldier pile wall. Review of the soldier pile calculations (Response to Correction Notice #5); indicate that an allowable passive lateral earth pressure of 300 pounds per cubic foot (pcf) was used in the design of the soldier pile wall. In my opinion, an allowable passive lateral earth pressure of 300 pcf would be appropriate if the ground surface in front of the soldier pile wall is level. The soldier pile wall along the west side of the house may undergo unacceptable deflection due to inadequate lateral resistance. The geotechnical engineer and structural engineer should have evaluated and revised the design as necessary. In my professional opinion, the passive lateral earth pressure inadequately accounts for the temporary excavation in front of the wall, jeopardizing the integrity of the site and presenting a potential safety hazard.
- My review of the Approved Building Permit Submittal Drawings and conditions indicates that the erosion control measures are inadequate.

- The slopes supporting portions of the shared access roadway may not be able to support the expected construction truck traffic. This will likely increase the potential of a slope failure involving the access roadway and represents a potential public safety hazard.
- Construction related vibration may result in damage to the wood wall on the property located at 4640 East Mercer Way.

In my opinion, the July 19, 2016 Statement of Risk prepared by PanGeo does not fully address the requirements of 19.07.060.D.2 of the MICC. All critical areas must be designated and their functions and values protected using the best available scientific information - known as "BAS". It does not appear as if BAS was used to evaluate the risk of the development on the surrounding properties. Though the Statement of Risk states that the development has been designed so that the risk to the subject property and adjacent properties has been eliminated or mitigated such that the site is determined to be safe, it provides no supporting documentation for that statement, as required by the code. For the reasons described above, it is my opinion there are likely significant adverse impacts as a result of inadequacy of the soldier pile wall, inadequate erosion control measures, and slope instability along the shared access road.

Based on my review of the approved plans and conditions observed during visits to the area, it is my opinion that construction of the proposed single family residence at 4634 East Mercer Way in Mercer Island, Washington will adversely impact critical areas on adjacent properties, thereby jeopardizing both public safety and property. Therefore, the project should not be allowed per Section 19.07.060.D.1 and of the MICC. In addition, the July 19, 2016 Statement of Risk prepared by PanGeo does not fully address the requirements of 19.07.060.D.2 of the MICC.

Thank you for the opportunity to be of service on this project. If you should have any questions or require clarification on any of the items discussed above, please call me at (206) 390-8742.

Sincerely,



Edward J. Heavey, P.E.
Geotechnical Engineer

EJH/ejh

[G:\BARCELO\COMMENT LTR\CRITICAL AREAS PERMIT COMMENT LTR101017.DOCX]

Cc: Ms. Rita V. Latsinova,
Stoel Rives LLP
600 University Street, Suite 3600
Seattle, Washington 98101

December 27, 2017

City of Mercer Island
Development Services Group
9611 SE 36th Street
Mercer Island, Washington 98040

Attn: Ms. Robin Proebsting, Senior Planner

Transmitted via email to: *robin.proebsting@mercergov.org, mpetri@copiersnw, and rita.latsinova@stoel.com*

**Re: Additional Comments
Proposed Single-Family Residence Development
4634 East Mercer Way, Mercer Island, Washington
City of Mercer Island Permit No. 1507-166**

Dear Ms. Proebsting:

This letter provides an update to comments presented in my October 10, 2017 letter regarding the proposed development at 4634 East Mercer Way in Mercer Island, Washington.

I understand that a waterline near the intersection of 46th Street SE and Dawn Drive reportedly failed on December 11, 2017. As I observed during a December 18, 2017 site visit, the failure resulted in severe erosion of the slope below the intersection. Reportedly, mud and debris was washed downslope eastward toward and across East Mercer Way then down a gully adjacent and north of a narrow drive way identified as 4600 Block. Given the steepness of the slope below the intersection of 46th Street SE and Dawn Drive and my past experience investigating similar types of slope failures, the failure of the water line was likely due to ongoing deformation of the steep slope below the intersection of 46th Street SE and Dawn Drive. Slope deformation can induce both lateral and vertical stresses on the waterline pipe, which likely resulted in the leak.

The driveway identified as 4600 Block is the shared access driveway that was discussed in my October 10, 2017 letter. As stated in my letter, I observed indications of instability of the slope along the portion of the roadway that extends eastward from East Mercer Way. Several trees along the top of the shared access roadway were observed to lean backwards, the fire hydrant is leaning outward, and two areas along the north edge of the shared access road have subsided and have several cracks parallel to the slope face. Observations made during a follow up site visit on September 24, 2017 indicated that the roadway has continued to subside in these two areas and the cracks have widened since my first visit in October 2015. Slope instability is likely a result of creep of the surficial soil on the slope below the roadway. The processes operating on the slope below the shared access roadway are similar to those acting on the steep slope below the intersection of 46th Street SE and Dawn Drive where the waterline failed on December 11, 2017.

In my October 10, 2017 letter, I had expressed concerns that the slope supporting the north side of the shared access roadway is at risk of not being able to support the expected construction truck traffic as a result construction-related activities of the proposed development at 4634 East Mercer

Way. Of particular concern is the waterline situated within the shared access roadway. Little is known about the condition of this waterline, including depth of burial and structural integrity. If there is insufficient cover over the pipeline, heavy wheel loads from trucks and/or slope movement caused by heavy trucks using the shared access road could damage the pipe resulting in leakage to potentially a complete failure of the pipe. I expect that a failure of the waterline within the shared access roadway will have similar consequences as the recent waterline failure near the intersection of 46th Street SE and Dawn Drive. If the waterline in the shared access roadway were to fail, the failure would result in significant impacts to the area, including flooding, property damage, and mud and debris flowing into Lake Washington.

Also in my October 10, 2017 letter, I had discussed potential impacts as a result of construction-related activities to the slope and wood wall on the Petrie property (4640 East Mercer Way) immediately east of the proposed development. During a November 6, 2017 site visit you attended, Ms. Petrie described the soil on the slope above the wall as “slippery.” By “slippery”, I believe she meant the soil is easily disturbed and prone to raveling and erosion. Raveling is generally defined as relatively rapid downslope movement of individual surface soil particles and/or shallow veneer surface soil layer and is similar to soil creep as both processes are chiefly driven by gravity and water. The soil composing the slope that is supported by the wood wall is composed of relatively clean sand and gravel that is prone to raveling and erosion when disturbed. As stated in my October 10, 2017 letter, the wood wall is fragile and there is a potential for construction related vibration to damage the wall resulting in impacts to the Petrie property. Impacts could include sloughing of soil onto the parking area adjacent to the house due to raveling and erosion.

If you should have any questions or require clarification on any of the items discussed above, please call me at (206) 390-8742.

Sincerely,

Edward J. Heavey, P.E.
Geotechnical Engineer



EJH/ejh

[G:\BARCELO\COMMENT LTR\ADDITIONAL COMMENT LTR122717.DOCX]

Cc: Ms. Rita V. Latsinova,
Stoel Rives LLP
600 University Street, Suite 3600
Seattle, Washington 98101

Mr. Mark Petrie
4640 East Mercer Way
Mercer Island, Washington 98040



600 University Street, Suite 3600
Seattle, WA 98101
T. 206.624.0900
F. 206.386.7500
www.stoel.com

RITA V. LATSINOVA
D. 206.386.7613
rita.latsinova@stoel.com

October 10, 2017

VIA EMAIL AND MESSENGER

RECEIVED
OCT 11 2017
CITY OF MERCER ISLAND
DEVELOPMENT SERVICE GROUP

Robin Proebsting, Senior Planner
Development Services Group
City of Mercer Island
9611 SE 36th Street
Mercer Island, WA 98040

Re: Comment on the Critical Area Determination CAO17-007 for the Proposed Development at 4634 East Mercer Way

Dear Robin Proebsting:

This comment is provided on behalf of Mark and Sarah Petrie, owners of 4640 East Mercer Way, the property that lies directly downgrade from the proposed development. It incorporates by reference and is supplemental to the prior comments submitted by the Petries and Ed Heavey, a geotechnical engineer, on their behalf.

The timing of the City's CAO17-007 in September of 2017, a year after the building permit was initially issued, is problematic. The purpose of the critical area determination is to establish, based on best available science, whether a proposed project is appropriate for a critical area (here, a geologically hazardous slope). The CAO determination should be made before the building permit and ancillary permits are issued.

When the critical area determination is made after the permits have been issued, it may indicate that the critical area determination is a mere afterthought. See, e.g., *King County v. Washington State Boundary Review Board for King County*, 122 Wn.2d 648, 860 P.2d 1024 (1993) (some government actions tend to "snowball" and acquire an unstoppable administrative inertia). That violates the requirement of the Growth Management Act to protect the function and values critical areas. RCW 36.70A.172(1); WAC 365-196-485(1)(b), (3)(d).

For the reasons identified in the above-referenced Heavey comment letter and based on our review of the documents provided by the City in response to Public Records Act requests, there is no evidence in the City's records that it provided any scientific information, much less the "best available science," that the project, as proposed, will not damage the adjacent critical areas,

Robin Proebsting, Senior Planner
October 10, 2017
Page 2

including the Petrie property. We urge the City to conduct a meaningful critical area determination based on the best available science and will act appropriately in the absence of it.

Very truly yours,



Rita V. Latsinova

RVL:srt

From: Ron Leibsohn
To: [Bruce Edwards](#); [Robin Proebsting](#)
Subject: RE: Further Comments on DSG# CA017-007/Building Permit #1507-166REV
Date: Thursday, December 14, 2017 2:12:05 PM

Robin, I am the owner of 4566 East Mercer Way adjacent to the north of the Edwards house. After reading Bruce's memo to you, I recalled a past incident that may have a bearing.

Approximately 30 years ago East Mercer Way at the point of the gully collapsed into a sink hole approximately 10' deep. At the time I recall the City engineers stating that the cause was the continuous flow of underground water beneath the street. That is evidence that in addition to other causes, there remains the threat of further destabilization of our roadway from this natural water flow. I suggest you and your staff research this matter and add this information to your determination.

Regards,

Ronald Leibsohn
rleibsohn@leibsohn.com
425-890-6737

From: Bruce Edwards [mailto:flysafe72@gmail.com]
Sent: Thursday, December 14, 2017 12:46 PM
To: Robin Proebsting <robin.proebsting@mercergov.org>
Subject: Further Comments on DSG# CA017-007/Building Permit #1507-166REV

Robin:

Please see the attached. I will be hand delivering a hard copy of this letter and the photographs later this afternoon.

Would you please respond via email to confirm your receipt of these materials?

As with my other correspondence, I am representing only myself and my family. Our other neighbors may have their own comments concerning the leak/mudflow described in my letter and what it potentially means for our neighborhood should a similar leak occur in the water line that underlies our access road.

Thank you,
Bruce Edwards

Bruce N. Edwards
Sorensen & Edwards, P.S.
701 Fifth Avenue, Suite 3300
Seattle, Washington 98104

(206) 224-8225 Direct
(206) 682-7100 Fax
(206) 947-5383 Cell

flysafe72@gmail.com

<http://www.sorensenandedwards.com>

31 CFR Part 10, Section 10.35, requires us to notify you that any tax advice in this electronic message was not intended or written to be used, and cannot be used, for the purpose of avoiding penalties.

The information contained in this message may be privileged and confidential and protected from disclosure. If the reader of this message is not the intended recipient, or an employee or agent responsible for delivering this message to the intended recipient, you are hereby notified that any dissemination, distribution or copying of this communication is strictly prohibited. If you have received this communication in error, please notify us immediately by replying to the message and deleting it from your computer.

READER BEWARE: Unencrypted, unauthenticated Internet messages may be corrupted or incomplete, may incorrectly identify the sender, and/or may be accessed by undesirable third parties through various means without the consent or approval of the sender or intended recipient. Please contact us if you wish to arrange for more secure communication or to authenticate this message.

From: Sarah Petrie
To: [Robin Proebsting](#)
Subject: CA017-007 4634 E. Mercer Way
Date: Friday, May 25, 2018 4:45:57 PM

Hello Robin,

I am writing on behalf of myself and my husband in regard to the proposed water runoff from CA017-007 4634 EMW.

Simply put, the solution suggested by Four Seasons Builders, Studio 19 Architects or Pan Geo to dump the runoff water from 4634 EMW

10 feet from the bulkhead is unacceptable to us. It is our understanding that they do have a 5 ft. easement on the southern property line

but dumping additional water onto the lowest portion of our property is unacceptable. We have had major damage to much of our landscaping

due to the flooding from the city storm drain that empties into the ravine above our property from EMW. I will be sending photos and videos of the flooding, erosion

and silt build up, next week. The Common Enemy Law may apply to our situation knowing that addition water onto our property would indeed cause damage.

For the builder, architect or geo company to use this as a solution to satisfy the Critical Water Course is unreasonable we are objecting to every aspect of it.

Sarah Petrie

4640 E. Mercer Way

Mercer Island, WA 98040

From: Sarah Petrie
To: [Robin Proebsting](mailto:Robin.Proebsting@mercer.gov)
Subject: Comments to reject Critical Area Determination CA017-007 for permit 1507-166
Date: Monday, October 9, 2017 10:16:09 AM

I had the wrong email.

Here we go again Robin,

Thanks,

Mark Petrie

From: Sarah Petrie [mailto:Dog-Pony@comcast.net]
Sent: Sunday, October 8, 2017 12:04 PM
To: 'Robin.Proebsting@mercer.gov.com'
Cc: Mark Petrie (mpetrie@copiersnw.com)
Subject: Comments to reject Critical Area Determination CA017-007 for permit 1507-166

Planning Development Services,

I Mark Petrie am the neighbor directly downhill in my own critical area and I am asking that the Planning Commission reject the proposal for the Barcelo, now 4 Seasons Builds plans for a rather large over 7,500' house on a steep nearly 40% grade Critical Area lot for the following reasons.

- 1) Poorly planned drainage that will further risk runoff onto my lot with greatly increased silt running into Lake Washington. See attached photos of a rain that does not include this development that several times per year floods my property. With the vast majority of the large tree canopy removed this will greatly increase the water runoff and silt coming downhill directly onto my property which is already having trouble with water runoff. I have three large Cedar trees near the lake that will likely die due to the pipe planned to run down the 5' easement along the South side of my property.
- 2) Risk of retaining wall collapse. See attached photos that show an old declining railroad timber retaining wall that will not stand the increased construction load, vibration and excess mud runoff as this is right next to my property line and 20' downhill from the lowest part of the 4634 lot to the East.
- 3) Public safety access problems. 14 households share this driveway and with 500+ dump truck trips simply to remove the trees and the 1,633 cubic yards of dirt to scalp this lot to make way for over 7,500' of home will impact my access plus many of the other neighbors that share this road. See attached photo for the 180 degree turn that is needed to access this lot for construction and for the future new owners. This will damage my property.

What recourse will I have when damage occurs to my property? What recourse will the neighbors have when they have limited access and the shared roadway is damaged by several hundred trips up and down this narrow already compromised roadway?

I ask that the Planning Commission deny this permit as it fails the 4 areas of "Statement of Risk" per

section 19.07.060.Di2 and for the 3 reasons listed above.

Mark Petrie
4640 EMW

From: Holly
To: [Robin Proebsting](mailto:Robin.Proebsting)
Cc: ashrik@aol.com
Subject: Official Comments on CA-017-007
Date: Thursday, October 5, 2017 11:13:37 AM

To the City of Mercer Island,
Thursday, Oct. 5th 2017

Comments on CA017-007

My husband and I reside at 4630 E. Mercer Way just above the proposed steep slope/building project at 4634 E. Mercer Way.

I want to insure that the steep slope modification/building project does not increase the possibility of a landslide on our property and neighboring properties. As you are aware, there is a very steep slope starting from E. Mercer at our house down through 4634 and to the water. There have been landslides, as shown in City maps in this area surrounding the lot.

I understand there is some discussion about allowing the project to start this fall through a wet season deviation for the project. I am concerned about this especially since it includes the removal of 20 large trees.

I also want to alert you to the fact that the road just south of our house on E. Mercer is dangerous due to erosion already. The ground next to the road on the downward side of the street has dropped 5 inches over the 17 years we have lived here. So, a car that goes off the edge of the road here may lose control. Please pass this information on to Public Works to investigate. Also, the water course detailed in the building proposal runs under the street here and down under a huge cottonwood tree and through the ravine next to 4634. Further erosion in this area could be dangerous.

Please pass on this information to Public Works and to the City Geotech who is reviewing this proposal.

Thank-you for documenting our comments on CA-017-007 and for all the good work you do.

Holly Shrikhande
4630 E. Mercer Way
206-455-5672

From: Thomas Trumble
To: [Robin Proebsting](#)
Cc: [Jim Pirak](#); [Sara Trumble](#)
Subject: Re: Subject: File CA017-007
Date: Thursday, September 21, 2017 2:58:38 PM
Importance: High

Robin:

Thank you for taking the time to speak with me. I have CC'd our neighbors who are closer to the proposed construction site. The project is so massive that 250 truck loads of dirt will have to be excavated. The scope is dangerous for the access roads that can barely take a single car. In addition to the roads, the water systems are over 60 years old and very fragile. Children use the route to access the bus stops for school. I don't think it is fair for the neighbors to endure a long and prolonged construction project. This is much closer to a commercial project. The damage from erosion and lake contamination is a real concern that will be hard to manage.

Tom

206 947-4120

> On Sep 20, 2017, at 10:18 PM, Thomas Trumble <mail@thomastrumble.net> wrote:

>

> Hi Robin:

> How do we submit a comment about this proposal. The slope is so steep that there will be erosion that could affect the hill side going as far up as EastMercer Way. The access road are not improved and cannot withstand the truck traffic without severe damage and the water lines are not protected.

>

> Thank You,

> Tom Trumble

> 4602 East Mercer Way

Gerald Yuen

4624 E Mercer Way
Mercer Island, WA 98040
gerald.yuen@gmail.com

October 9th 2017

RE: Building Permit No: 1507-166

To Whom It May Concern,

I'm Gerald Yuen. My Family resides in 4624 E Mercer Way and we are writing to express our deepest concern on Barcelo Homes' proposed construction of an oversized 7500 sqft home in 4634 E Mercer Way, situated on a densely wooded sloped terrain with limited easement access that would severely affect our quality of life, cause undue property damages and dire environmental consequences.

We are the sole easement holder that grants exclusive access to the homes of 4616, 4632 and 4640 E Mercer Way. We were approached by Barcelo Homes to purchase our easement rights for access to the new home to be constructed in 4634 E Mercer Way. Since then, we made several inquiries into the construction project and its potential negative impact on the neighborhood and environment. In response, Barcelo Home has subsequently redesigned the house to utilize the existing easement access of 4640 E Mercer Way which will greatly impede ingress and egress to our surrounding neighbors.

It is clear that Barcelo Homes is not acting on our neighborhood's best interest. Service vehicles have already overburdened our narrow driveway over the years. The estimated required dump truck loads of over 200 runs for the oversized 7500 sqft property construction will most certainly damage our roads and surrounding properties. It would also create severe traffic congestions as well as safety concerns for foot and car traffic during and post construction.

Another major concern we have is the fate of the bald eagles nesting in our neighborhood. We have been living in our property for over 10 years, and we are well aware that the 4634 E Mercer Way parcel is home to a bald eagle nest. The Bald and Golden Eagle Protection Act prohibits any tree removal containing an active or inactive eagle nest without obtaining a permit from the US Fish & Wildlife Services. It is not only a felony to displace the home of the bald eagles without a proper permit, but would be detrimental to the wildlife habitat in the surrounding area.

We sincerely ask that the City of Mercer Island to reconsider the far reaching impact of the construction of an oversized house that will affect the quality of life for our family and neighbors for many years to come.

Sincerely,

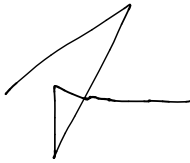
A handwritten signature in black ink, consisting of a large, stylized 'G' followed by a horizontal line and a small vertical stroke at the end.

Gerald Yuen



PUBLIC NOTICE OF APPLICATION



NOTICE IS HEREBY GIVEN that the City of Mercer Island has received the application described below:

File No.: CAO17-007

Description of Request: Request for approval of a critical area determination in order to modify a steep slope, associated with construction of a new single family residence.

Applicant / Owner: Paul Maksimchuk / Four Season Homes LLC

Location of Property: 4634 E Mercer Way, Mercer Island, WA, 98040;
Identified by King County Assessor tax parcel number: 755870008

SEPA Compliance: The proposal is SEPA exempt under WAC 197-11-800(6)(e).

Project Documents: Please follow this file path to access the associated documents for this project: <https://mieplan.mercergov.org/public/CAO17-007/>

Written Comments: **This may be the only opportunity to comment on this proposal.** Written comments on this proposal may be submitted to the City of Mercer Island either by email, in person, or by mail to the City of Mercer Island, 9611 SE 36th Street, Mercer Island, WA 98040-3732. Anyone may comment on the application, receive notice, and request a copy of the decision once made.

Only those persons who submit written comments or participate at the public hearing (if a hearing is required) will be parties of record; and only parties of record will have the right to appeal.

Public Hearing and Public Meeting: Pursuant to MICC 19.15.010(E) and MICC 19.15.020(F)(1), a public hearing is not required for this proposal.

Applicable Development Regulations: Applications for Critical Area Determinations are required to be processed as Administrative Actions pursuant to Mercer Island City Code (MICC) 19.15.010(E). Processing requirements for an Administrative Action are further detailed in MICC 19.15.020.

Other Associated Permits:

Building permit 1507-166REV

Environmental Documents:

A copy of all studies and / or environmental documents is available through the above project documents link.

Application Process Information:

Date of Application: June 14, 2017
Determined to Be Complete: August 31, 2017
Bulletin Notice: September 11, 2017
Date Mailed: September 11, 2017
Date Posted on Site: September 11, 2017
Comment Period Ends: 5:00PM on October 11, 2017

The project is available for review at the City of Mercer Island, Development Services Group, 9611 SE 36th Street, Mercer Island, Washington.

Project Contact:

Robin Proebsting, Senior Planner
Development Services Group
City of Mercer Island
9611 SE 36th Street
Mercer Island, WA 98040
(206) 275-7717

robin.proebsting@mercergov.org

LITCHFIELD ENGINEERING
Civil Engineering & Development Services

12840 81st Avenue NE, Kirkland, WA 98034
tel 425-821-5038 fax 425-821-5739 ka.litchfield@frontier.com

January 22, 2019

City of Mercer Island
Development Services Group
9611 SE 36th Street
Mercer Island, WA 98040

Subject: Response to Public Comments: City of Mercer Island Permit SEP18-021
Project Name: Four Season East Mercer Way SFR
Project Address: 4634 E. Mercer Way

Reference: Litchfield Engineering Plans; Dated January 22, 2019
Date: January 22, 2019

Ms. Proebsting:

This letter is intended to provide a response to drainage related comments received by the City of Mercer Island during the processing and review of SEPA application 18-021 for the subject project. Minor revisions to the civil engineering plans were also completed to address the comments.

Project Overview:

The proposed work involves the construction of a new single family home on a vacant lot. The new single family home will be constructed on the mid portion of the 0.49 acre property. The property is bordered to the east by the Petrie property which is located adjacent to Lake Washington (TPN 755870-0006); to the south by the Brotherton property (TPN 182405-9030); to the west by the Shrikhande property (TPN 755870-0004); and to the north by the Yuen property (TPN 755870-0020). Access to the future home site is from a private road that also provides access to 12 other developed properties. The private road connects to East Mercer Way. The property is Parcel B of Sandy Beach Plat Number 76-12-036 Recording Number 770106-0821.

Existing Drainage Description:

As is typical of many undeveloped properties on Mercer Island, the Four Season property is characterized by moderate to steep slopes, evergreen/deciduous trees, and thick undergrowth. Based on the localized topography, the property drains primarily to the east but also to the northeast and southeast. Surface drainage presently migrates across thick heavily vegetated slopes. The runoff either infiltrates naturally into the ground or sheet flows across developed property before entering Lake Washington. A natural water course borders the property along its' southern property line and has been defined and delineated as a Type 3 stream corridor. This stream corridor conveys the tributary upstream drainage across the southern boundary of the Four Season property, across the Petrie property, and then into Lake Washington. It should be noted that the water course shows no clear definition typical of an open channel with side slopes.

Developed Drainage System:

All hard surfaces from roof areas, patios, walkways, and the access driveway will be collected, conveyed, and discharged directly to Lake Washington in a high-density polyethylene (HDPE) tight-line pipe. Roof downspouts, footing drains, area drains, and trench drains will all be collected on-site via underground piping and conveyed via an at grade HDPE tight-line. Given the elevation of the project's access driveway a pump system will be utilized to control surface drainage from this area. The pump system will be an alternating duplex system (i.e. two pumps) and be provided with safeguards to notify the property owner in the event of a pump failure. To insure that the pumps operate at all times, including during a power outage, a standby generator will be integrated into the project development.

The HDPE conveyance pipe will be anchored to the ground at several locations along its' alignment. Beyond the Four Season property boundary the piping will be placed within a 5' recorded drainage easement (K.C. Rec. No. 7701060821).

Surface Water Quantity & Controlled Discharge

Surface drainage from the water course tributary basin would technically be considered intermittent. Periods during the wetter months, or extreme storm events, channel flow can be observed. During the summer months the open channel is dry. The Four Seasons development will not increase the natural drainage that can be periodically observed within the water course. Since all drainage from the developed site will be tight-lined to Lake Washington, an actual decrease in channel flow from the Four Season property will be realized.

To insure that channel flow remains unrestricted the outfall pipe will be elevated where it crosses the stream channel. The actual location of the elevated crossing will be field located at the time of construction by the project field biologist. No reduction in the channel capacity will occur as a result of the Four Seasons development.

The pipe will be anchored along its' planned alignment (within the drainage easement) to Lake Washington. The point of discharge, and end of the pipe, will be into a constructed concrete channel. The outfall (i.e. end of the pipe) will be located 9' from the existing bulkhead and the concrete outfall structure will be rock-lined, 3' wide, 18" high, and 10' long. The discharge pipe will be anchored to the outfall structure. A cap will be placed over the concrete channel to insure the discharged water remains within the channel prior to discharge into the lake.

The King County Runoff Time Series (KCRTS) hydrologic model was utilized to calculate the 100-year storm event of 0.0071 CFS from the Four Seasons project. The capacity of a 6" HDPE pipe flowing full using Manning's formula is 0.86 CFS at a slope of 2.0%. Based on this analysis a factor of safety of 121 is provided for the Four Season's private tight-line system. A 6" pipe system is more than adequate to safely convey the developed drainage from the project site to Lake Washington.

Conclusion:

Drainage from the proposed project will be collected and conveyed in a tight-line system to Lake Washington. Although it is likely minor landscape areas may bypass the on-site collection points, these areas are expected to be insignificant to the project's overall drainage control. Exhibit 17

Robin Proebsting: City of Mercer Island Development Services Group

January 22, 2019

Page 3

hard surfaces such as roof, patio, driveway, walks, etc. will be collected and safely discharged to the lake. Upon completion of the project drainage system and landscaping, no drainage related issues or problems are expected to result from development of the property as planned.

I am hopeful that the above will sufficiently address the concerns regarding the developed drainage from this project. I am hopeful the final review and project approval will be forthcoming in the near future. I thank you in advance for the time that you have committed to this project.

Sincerely,

Litchfield Engineering



Keith A. Litchfield, P.E.

Copy: Paul and Megan Maksimchuck, Four Season Homes
Steven Long, Studio 19 Architects

Attah: Litchfield Engineering Plans dated January 22, 2019